

--	--	--	--	--	--	--

**Anglo-Chinese School (Junior)/
Anglo-Chinese School (Primary)**



**COMBINED PRELIMINARY EXAMINATION (2019)
PRIMARY 6**

MATHEMATICS

**PAPER 1
Booklet A**

Friday

23 August 2019

1 h

INSTRUCTIONS TO PUPILS

1. Do not turn over this page until you are told to do so.
2. Follow all instructions carefully.
3. Answer all questions.
4. Shade your answers in the Optical Answer Sheet (OAS) provided.
5. The use of calculators is **NOT** allowed.

Name : _____ ()

Class : 6 ()

This question paper consists of 10 printed pages. (Inclusive of cover page)

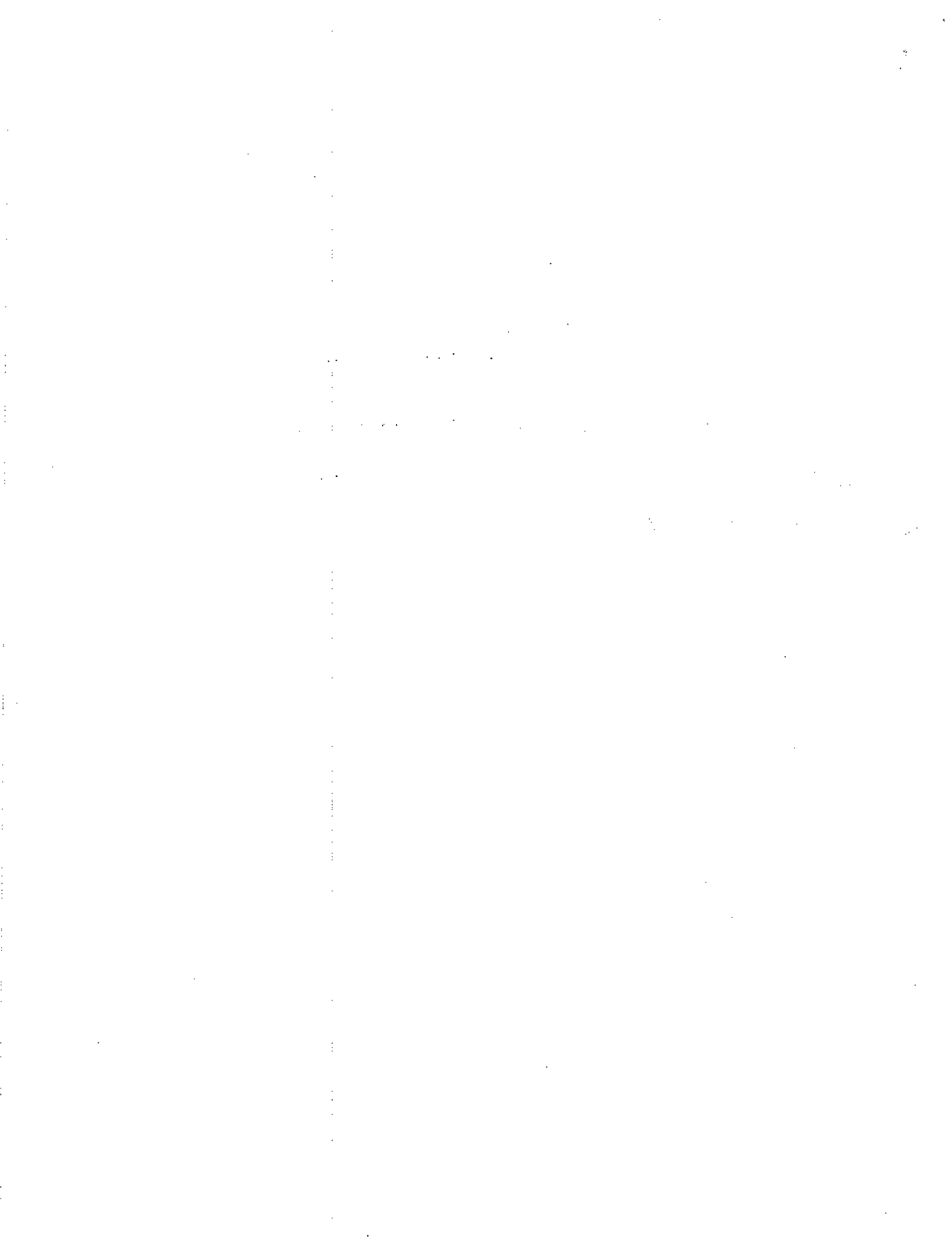

Questions 1 to 10 carry 1 mark each. Questions 11 to 15 carry 2 marks each.
For each question, four options are given. One of them is the correct answer.
Make your choice (1, 2, 3 or 4) and shade your answer on the Optical Answer
Sheet (OAS). (20 marks)

1. Express 3080 cm in m.

- 1) 3.08 m
- 2) 3.80 m
- 3) 30.08 m
- 4) 30.80 m

2. Round 123.456 to the nearest hundredth.

- 1) 120.00
- 2) 123.50
- 3) 123.45
- 4) 123.46

3. Two containers with some water are shown below.
How much more water is there in Container B than in Container A?

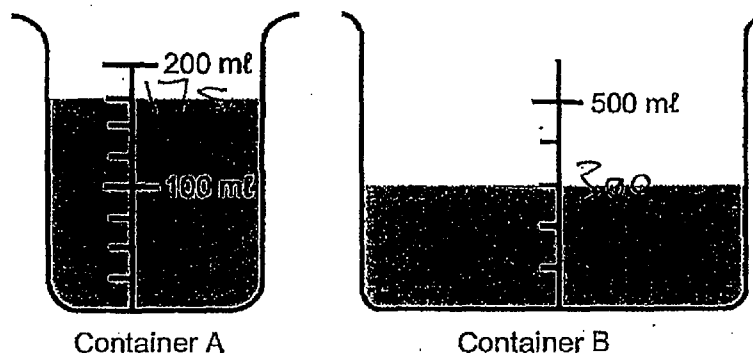

- 1) 125 ml
 - 2) 175 ml
 - 3) 300 ml
 - 4) 475 ml
4. Which of the following is the same as 7040 cm^3 ?

- 1) 7 l 4 ml
- 2) 7 l 40 ml
- 3) 70 l 4 ml
- 4) 70 l 40 ml

5. The graph shows the number of chairs sold by a shop from May to August. In which two months were a total of 76 chairs sold?

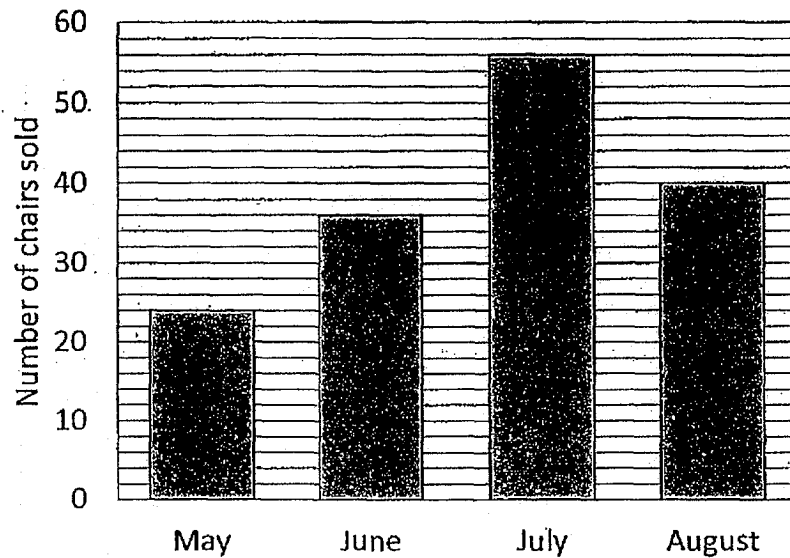

- 1) May and June
 - 2) May and July
 - 3) June and August
 - 4) July and August
6. Which of the following fractions is closest to 4?

- 1) $3\frac{1}{2}$
- 2) $3\frac{1}{6}$
- 3) $4\frac{1}{4}$
- 4) $4\frac{1}{5}$

7. How many whole numbers from 29 to 62 are divisible by 5?

- 1) 6
- 2) 7
- 3) 12
- 4) 18

8. In the diagram, A, B, and C are three points on the ground. Point A is north of Point B and $\angle ABC$ is 135° . In what direction is Point C from Point B?

- 1) North-East
- 2) North-West
- 3) South-East
- 4) South-West

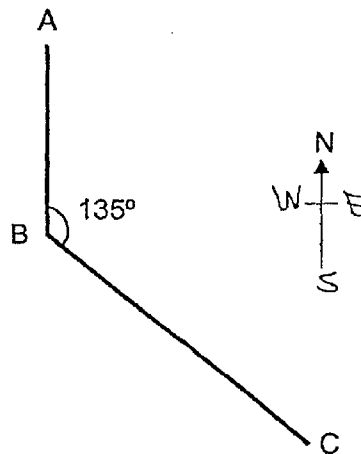

9. Which of the letters below has parallel lines and no perpendicular lines?

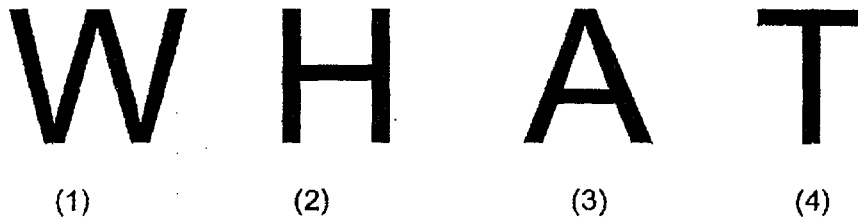

10. The graph shows the height of a plant from Jan to May.
In which of the following periods did the plant grow by 24 cm?

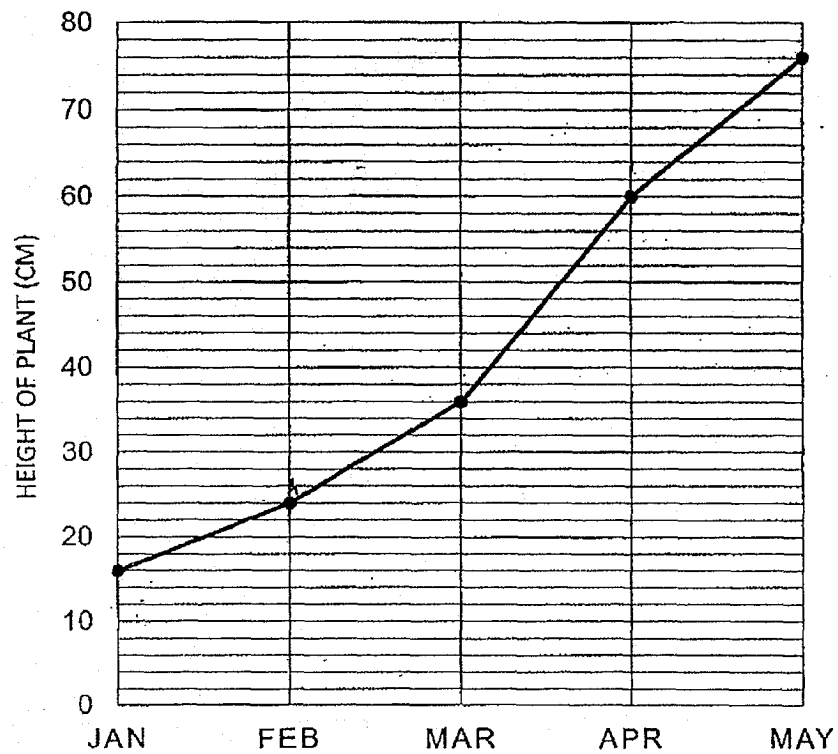

- 1) Jan to Feb
- 2) Feb to Mar
- 3) Mar to Apr
- 4) Apr to May

11. The figure is made up of four quarter circles of radius 10 cm. Find the perimeter of the figure. (Take $\pi = 3.14$)

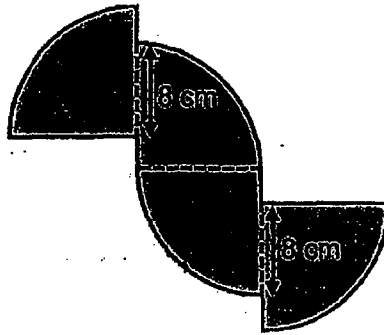

- 1) 90.8 cm
2) 82.8 cm
3) 71.4 cm
4) 59.4 cm
12. Ben, Charlotte and Danny have some marbles. The ratio of the number of marbles Ben has to the number of marbles Charlotte has is 2 : 7. The total number of marbles Ben and Charlotte have is three times as many as the number of marbles Danny has. Ben and Danny have 300 marbles. How many marbles does Charlotte have?
- 1) 120
2) 180
3) 420
4) 720

13. Mrs Tan had 9 kg of flour. She used $\frac{1}{3}$ of it to bake a cake. After that, she used $\frac{1}{2}$ kg of the flour to bake some cookies. How much flour had she left?

1) $1\frac{1}{2}$ kg

2) $4\frac{1}{6}$ kg

3) $5\frac{1}{2}$ kg

4) $8\frac{1}{6}$ kg

14. 9 cubes are stacked to form the solid below.

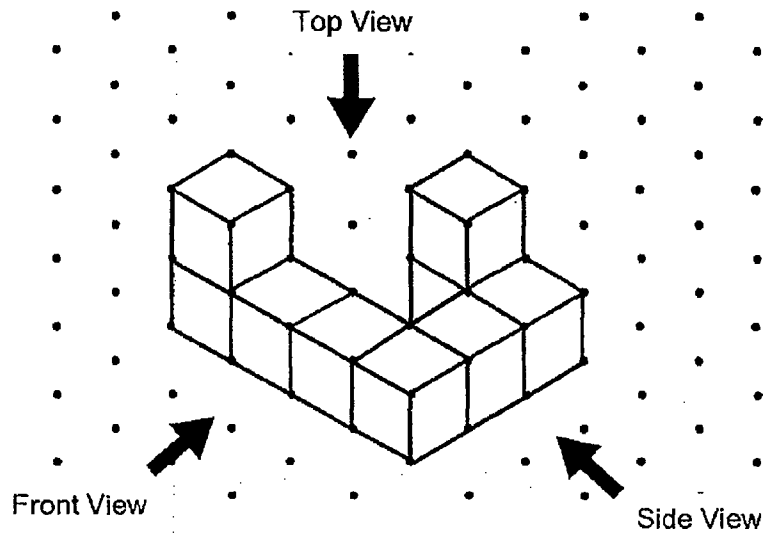

Which of the following is the top view of the solid?

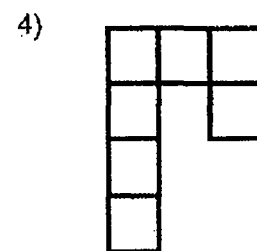
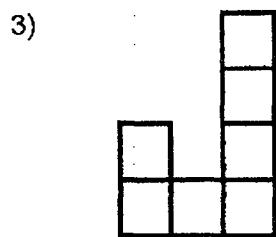
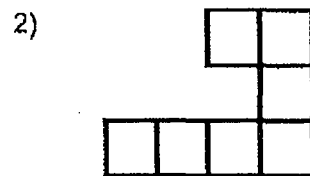
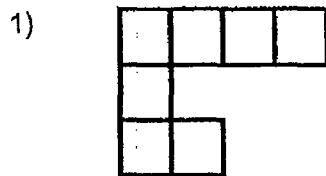

15.

PARKING FEES	
For first hour	\$2.20
Every subsequent $\frac{1}{2}$ hour or part thereof	\$0.80

Miss Ranjit parked her car from 9.00 a.m. to 2.15 p.m. How much did she pay for her parking?

- 1) \$6.20
- 2) \$6.40
- 3) \$8.80
- 4) \$9.40

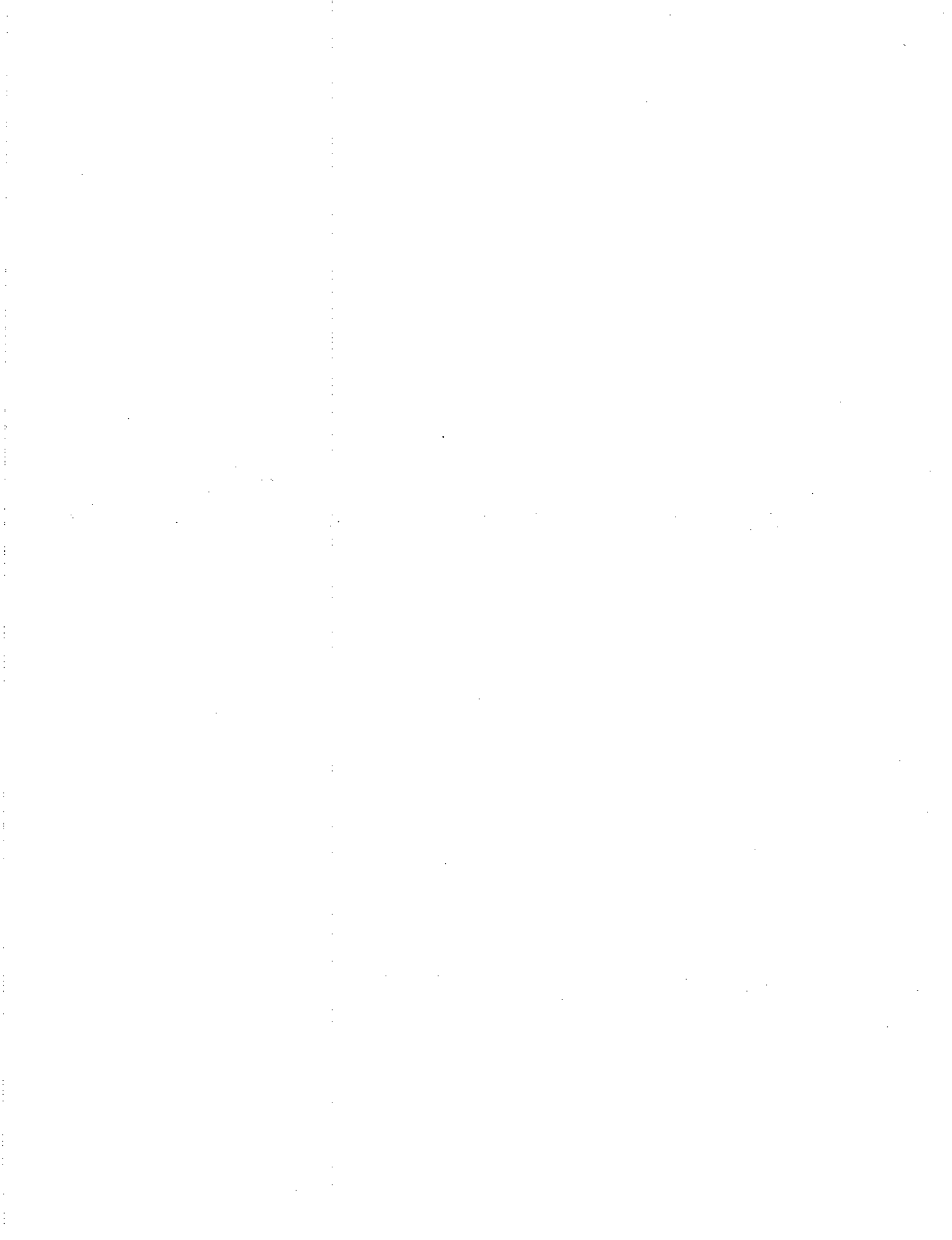

--	--	--	--	--	--	--

**Anglo-Chinese School (Junior)/
Anglo-Chinese School (Primary)**



**COMBINED PRELIMINARY EXAMINATION (2019)
PRIMARY 6**

MATHEMATICS

**PAPER 1
Booklet B**

Friday

23 August 2019

1h

INSTRUCTIONS TO PUPILS

1. Do not turn over this page until you are told to do so.
2. Follow all instructions carefully.
3. Answer all questions.
4. Write your answers in this booklet.
5. The use of calculators is **NOT** allowed.

Name : _____ ()

Class : 6.()

This question paper consists of 10 printed pages. (Inclusive of cover page)

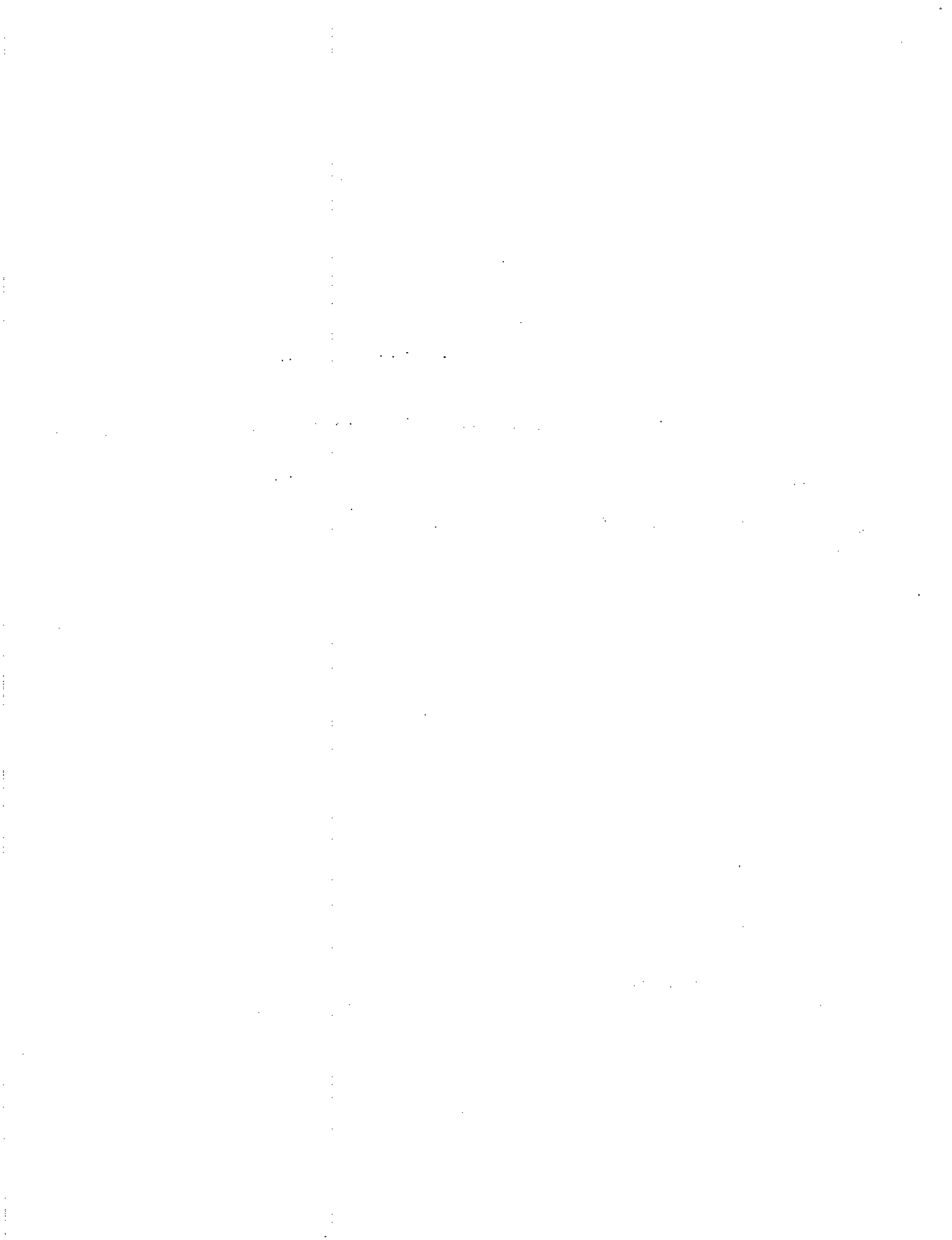

Questions 16 to 20 carry 1 mark each. Write your answers in the spaces provided.
For questions which require units, give your answers in the units stated.

(5 marks)

16. Ashley watched a movie that lasted for 149 minutes. The movie started at 11.05 a.m. At what time did the movie end?

Answer: _____ p.m.

17. Express $\frac{3}{11}$ as a decimal. Give your answer correct to 2 decimal places.

Answer: _____

--

18. The figure shows a cuboid with a square base of side 3 m.
The volume of the cuboid is 54 m^3 . Find the height of the cuboid.

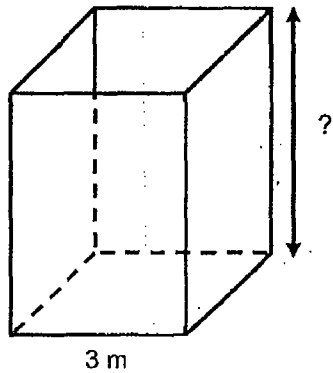

Answer: _____ m

19. Find the value of $2 - 0.008$.

Answer: _____

20. The figure shows a rectangular glass box filled with some unit cubes. How many more cubes are needed to fill the box completely?

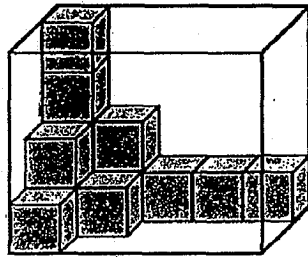

Answer: _____

Questions 21 to 30 carry 2 marks each. Show your working clearly and write your answers in the spaces provided. For questions which require units, give your answers in the units stated. (20 marks)

21. The square below is made up of 4 identical rectangles. The perimeter of each rectangle is 40 cm. What is the area of the square?

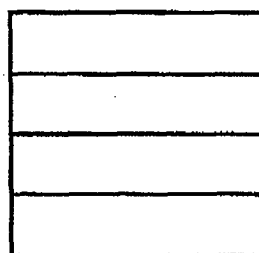

Answer: _____ cm²

22. Laura has m pencils. Tom has twice as many pencils as Laura. They each bought another 7 pencils. How many pencils do they now have altogether in terms of m ?

Answer: _____

23. The average of a 1-digit number, a 2-digit number and a 3-digit number is 368. What is the smallest possible 1-digit number?

Answer: _____

24. The pie chart represents the number of each type of animals in a farm. There is an equal number of horses and chickens. There are 15 horses and $\frac{2}{5}$ of the animals are cows. How many cows are there?

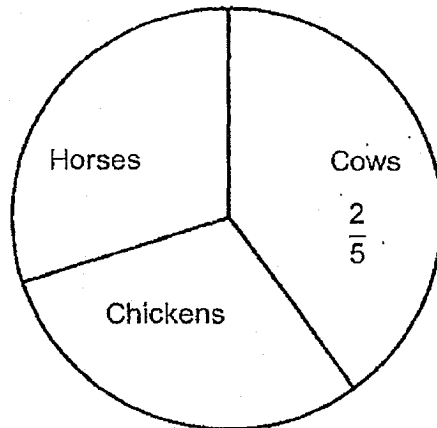

Answer: _____

25. Peter had 80 stickers. He used $\frac{1}{4}$ of his stickers and gave 30% of the remaining stickers to Elijah. How many stickers had Peter left?

Answer: _____

26. Daniel paid \$4800 for a laptop and 5 cameras. A laptop cost 3 times as much as a camera. How much did the laptop cost?

Answer: \$ _____

27. Susan has $\frac{7}{11}$ as many candies as Mary. After ~~Susan~~^{Mary} gave 52 candies to Mary, both of them had the same number of candies. How many candies did Susan have at first?

Answer: _____

28. A triangle RST is drawn on the square grid below. Draw and label a rectangle STUV on the square grid such that the area of triangle RST is $\frac{2}{3}$ the area of rectangle STUV.

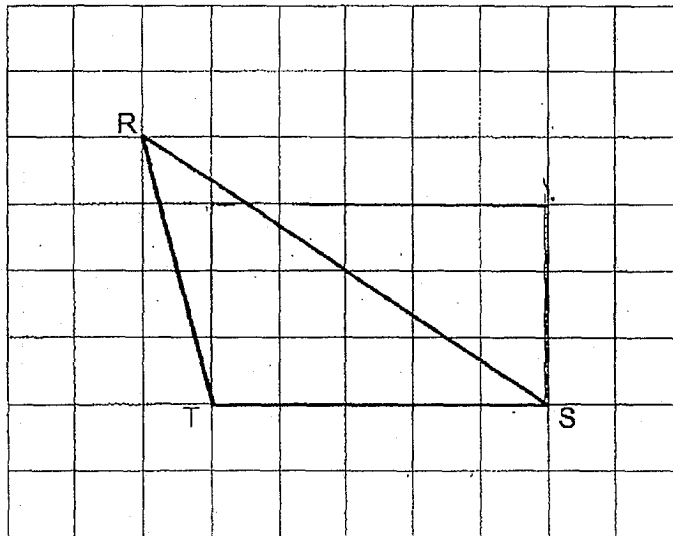

29. The figure below is an incorrect net of a cube. Put two crosses (X) on the two square faces which are incorrect.

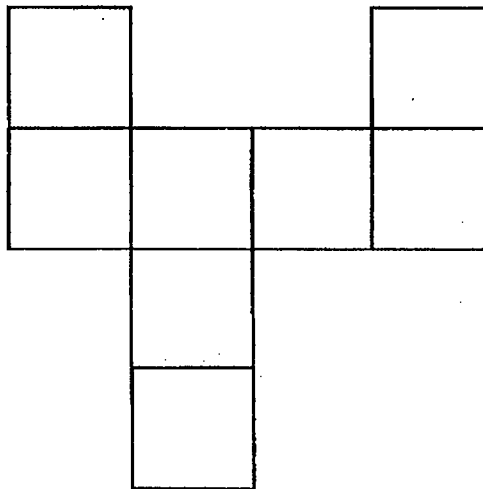

30. In the figure below, CDEF is a rhombus with $\angle DEF = 108^\circ$. ABCD is a trapezium with CD parallel to EF and $\angle ADC = 35^\circ$. Find $\angle BCF$.

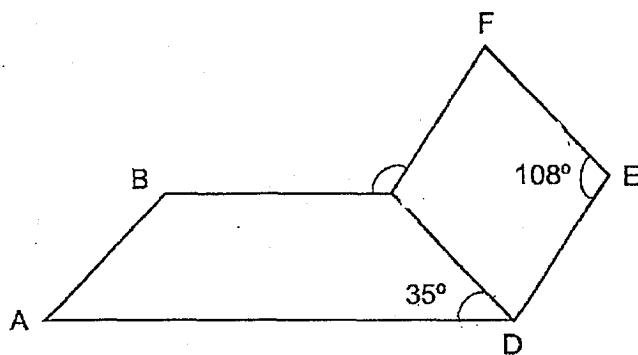

Answer: _____°

End of Paper 1



--	--	--	--	--	--

**Anglo-Chinese School (Junior)/
Anglo-Chinese School (Primary)**



**COMBINED PRELIMINARY EXAMINATION (2019)
PRIMARY 6**

MATHEMATICS

PAPER 2

Friday

23 August 2019

1 h 30 min

INSTRUCTIONS TO PUPILS

1. Do not turn over this page until you are told to do so.
2. Follow all instructions carefully.
3. Answer all questions.
4. Show all your workings as marks are awarded for correct working.
5. Write your answers in this booklet.
6. The use of an approved calculator is expected, where appropriate.

Name : _____ ()

Class : 6.()

Parent's Signature: _____

Booklet / Paper	Possible Marks	Marks Obtained
Booklet A	20	
Booklet B	25	
Paper 2	55	
Total	100	

This question paper consists of 15 printed pages. (Inclusive of cover page)

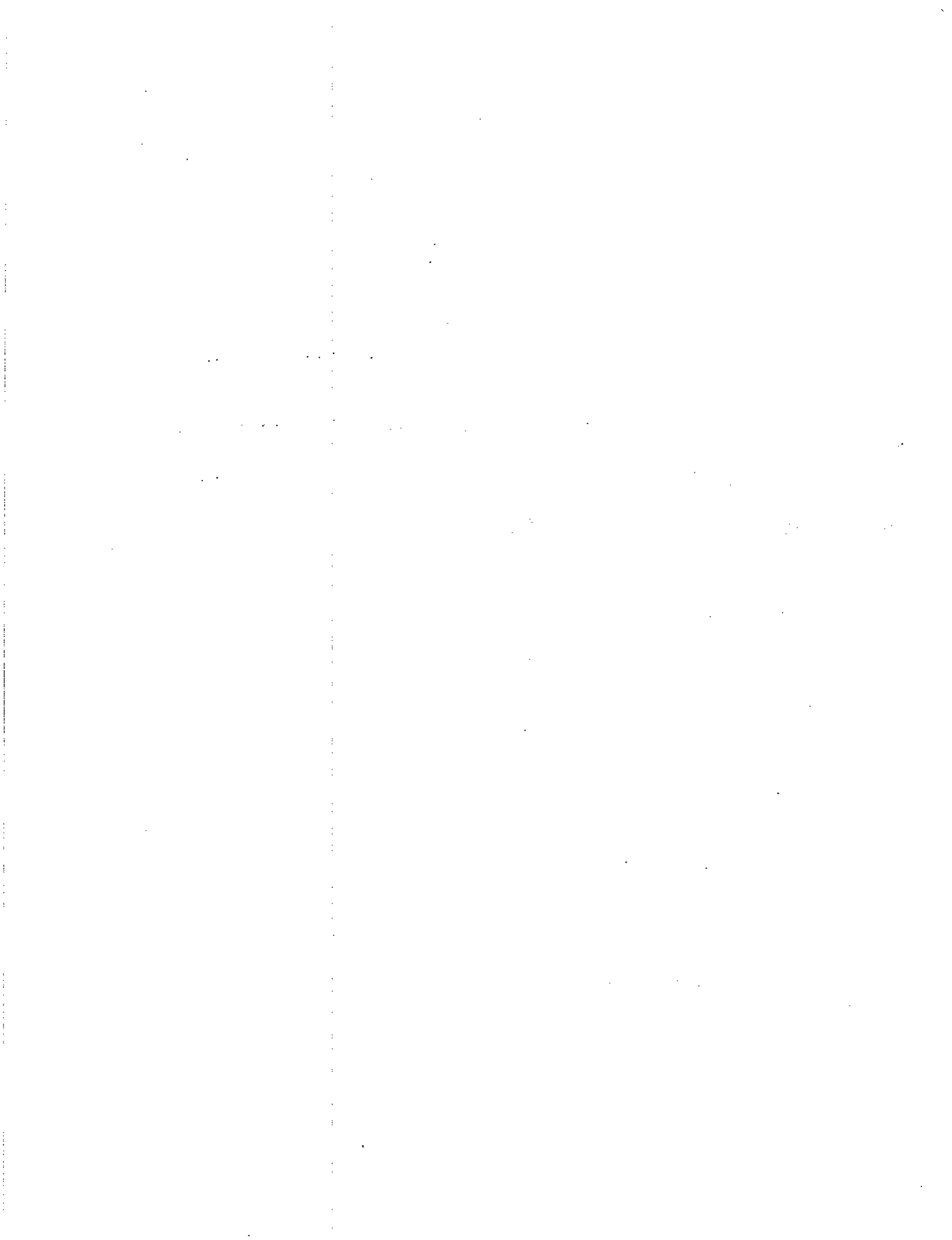

Questions 1 to 5 carry 2 marks each. Show your working clearly and write your answers in the spaces provided. For questions which require units, give your answers to the units stated. (10 marks)

1. John cut out a quarter circle with a radius of 10 cm from a piece of rectangular paper as shown below. What is the perimeter of the shaded part? (Take $\pi = 3.14$)

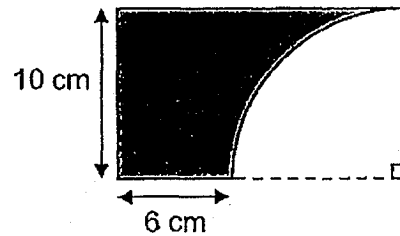

Answer: _____ cm

2. The table shows the number of pupils with the following scores.

Score	11	12	13	14	15
Number of pupils	3	1	0	2	4

What was the average score of all the pupils?

Answer: _____

3. Mrs Lim bought some beads for Jessica and Karen. For every 8 beads Jessica took, Karen took 5. In the end, Jessica had 216 more beads than Karen. How many beads did Mrs Lim buy?

Answer: _____

4. In the grid below, draw and label an isosceles triangle PQR in which $PQ = QR$ and $\angle PQR$ is 120° . The line PQ is drawn for you.

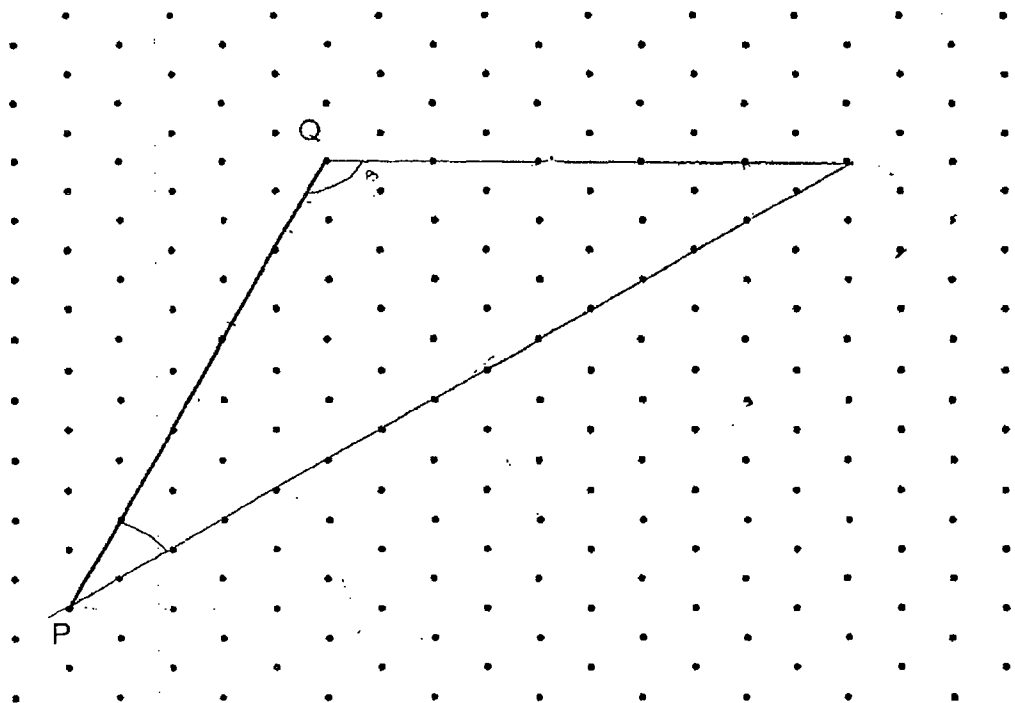

5. At a carnival, 80% of the muffins were sold at full price and the remaining 60 muffins were sold at half price. The total amount of money collected from the sale of muffins was \$864. What was the full price of a muffin?

Answer: \$ _____

For questions 6 to 17, show your working clearly and write your answers in the in the spaces provided. The number of marks available is shown in brackets [] at the end of each question or part-question. (45 marks)

6. Amy had \$24.80 more than Beatty at first. After Beatty gave \$14.20 to Amy, Amy had 3 times as much money as Beatty in the end. How much did Beatty have at first?

Answer: _____ [3]

7. In the figure, AED and EBF are straight lines and BCDE is a parallelogram. Find $\angle y$.

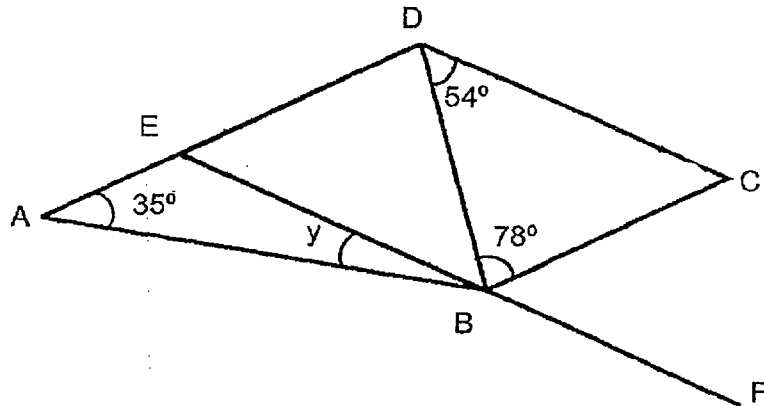

Answer: _____ [3]

--

8. A shirt cost $\$8n$. A tie cost half as much as the shirt.
- a) Mr Tan bought 6 identical ties and 1 shirt. How much money did he spend in terms of n ?
- b) Mr Tan spent $\$256$ on 6 identical ties and 1 shirt. Find the value of n .

Answer: (a) _____ [2]

(b) _____ [1]

--

9. The line graph shows the number of books borrowed from a library from Monday to Friday.

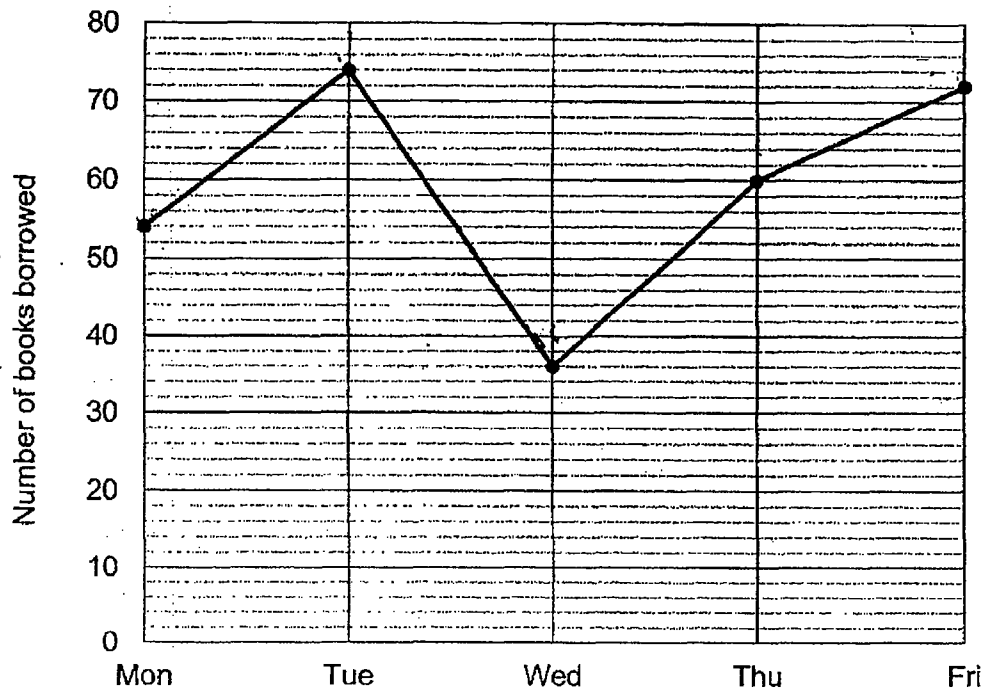

- (a) In which 1-day period was there the biggest change in the number of books borrowed?
- (b) Which were the two days when the ratio of the number of books borrowed were 3 : 4?

Answer : (a) _____ to _____ [1]

(b) _____ and _____ [2]

10. Eddie and his sister walked from home to school. His sister started walking at 8.00 am at an average speed of 50 m/min. Eddie started walking at 8.05 am at a speed of 60 m/min. Eddie caught up with his sister at mid-point between the school and his home. Find the distance between Eddie's home and the school.

Answer: _____ [3]

11. The pie chart shows the different types of fruits in a shop.
There was an equal number of grapes and apples.
There were 16 more mangoes than grapes.
There were 200 fruits altogether.

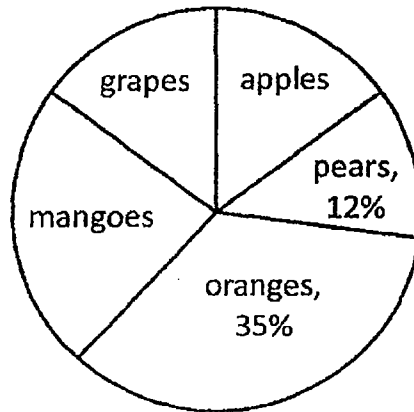

- (a) What was the total number of mangoes, grapes and apples?
(b) How many apples were there?

Answer: (a) _____ [2]

(b) _____ [2]

12. The ratio of the number of boys to the number of girls in Group A was 4 : 1. The ratio of the number of boys to the number of girls in Group B was 2 : 3. There were twice as many children in Group A as in Group B.
- (a) What was the ratio of the number of boys in Group A to the number of boys in Group B?
- (b) 10 boys and 10 girls left in Group B. The ratio of the number of boys in Group B to the number of girls in Group B became 1 : 2. How many children were there in Group A?

Answer: (a) _____ [2]

(b) _____ [2]

--

13. The figure shows an empty flower vase of height 20 cm. It is made from two containers. The top container is in the form of a cuboid which has a square base of 3 cm and a height 12 cm. The bottom container is in the form of a cuboid, measuring 15 cm by 9 cm by 8 cm.

$\frac{1}{8}$ l of water is poured into the empty vase.

Find the height of the water level from the base of the vase.

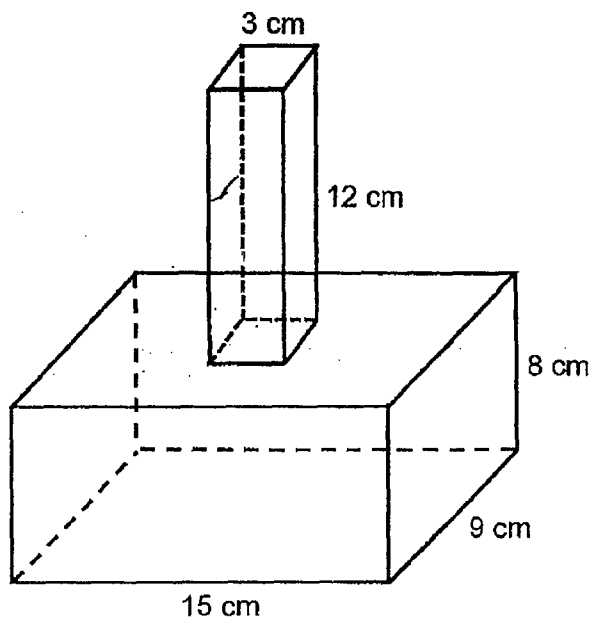

Answer: _____ [4]

14. Joyce had some money. She bought a dress, a shirt and a watch. She spent $\frac{1}{5}$ of her money on the shirt. The shirt cost \$24 less than the dress. The watch cost \$102. She was left with $\frac{1}{4}$ of the amount of money she had at first. How much money did Joyce have at first?

Answer: _____ [4]

15. Box A contained only 50-cent coins while Box B contained only 20-cent coins. Box B has 60 more coins than Box A but the value of all the coins in Box A is \$4.50 more than the value of all the coins in Box B. Find the amount of money in Box A.

Answer: _____ [4]

16. In the figure shown below, PQRS is a trapezium. $PS \parallel VR$ and $VR = QR$. PST is a straight line.

a) Find $\angle e$.

b) Find $\angle f$.

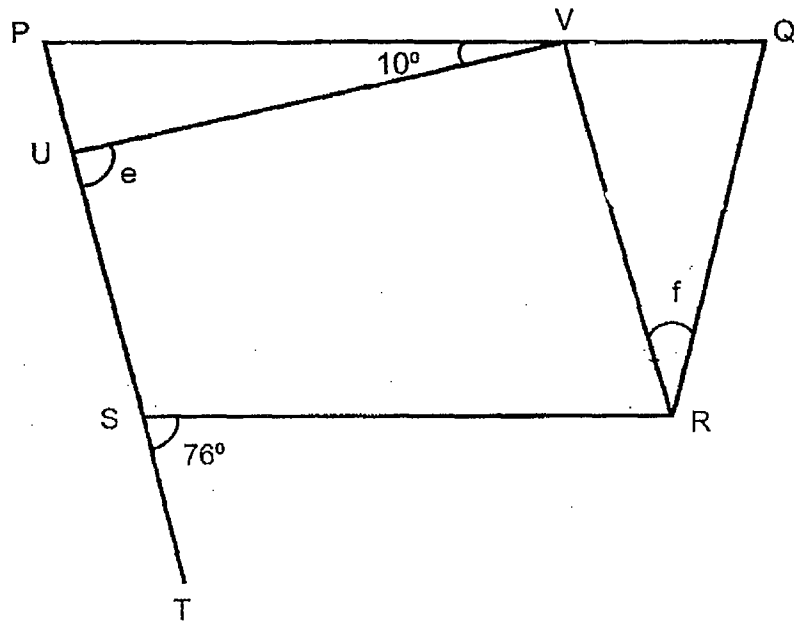

Answer: (a) _____ [3]

(b) _____ [2]

--

17. A figure is drawn on a square piece of paper with length 40 cm as shown below. Its outline consists of 2 identical large quarter circles, 1 smaller quarter circle, 1 semicircle and 3 straight lines. The length of AB is 4 cm.

- (a) What is the area of the figure?
 (b) What is its perimeter?

(Take $\pi = 3.14$)

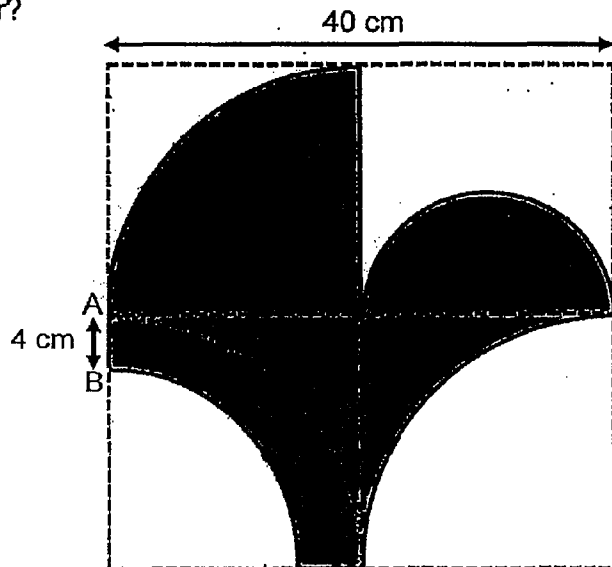

Answer: (a) _____ [3]

(b) _____ [2]

End of Paper 2

--

Answer Sheets

ACS Pri 6 SA2/2019 MATHS

Paper 1

1.	4		6.	4		11.	1
2.	4		7.	2		12.	3
3.	1		8.	3		13.	3
4.	2		9.	1		14.	2
5.	3		10.	3		15.	4

16. 1.34pm 17. 0.27 18. 6m 19. 1.992 20. 47 21. 256cm²
 22. 3m+14 23. 6 24. 20 25. 42 26. \$1800 27. 182

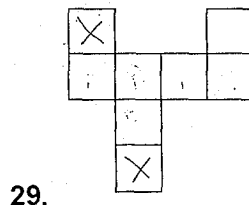
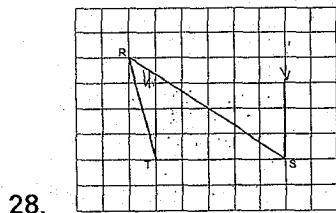

30. 107°

Paper 2

1. 47.7cm 2. 13.3 3. 936 4. 5. \$3.20

6. \$40.80 7. 13° 8a. \$32n 8b. \$8.300

9a. Tuesday to Wednesday 9b. Monday to Friday 10. 3 Km

11a. 106 11b. 30 12a. 4: 1 12b. 100 13. 13cm 14. \$360

15. \$27.50 16a. 86° 16b. 28° 17a. 756.04cm² 17b. 147.32cm

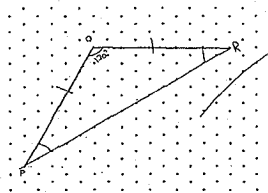



AI TONG SCHOOL

2019

PRELIMINARY EXAMINATION

PRIMARY 6

STANDARD MATHEMATICS

PAPER 1

(Booklets A and B)

DURATION : 1 h

DATE : 23 AUGUST 2019

INSTRUCTIONS

Do not open the booklet until you are told to do so.

Follow all instructions.

Answer all questions.

Shade your answers in the Optical Answer Sheet (OAS) provided.

You are **not** allowed to use a calculator.

Name: _____ ()

Class: Primary 6 _____

Marks:

6M _____

Paper 1	45
Paper 2	55
Total	100

Parent's Signature : _____

Date : _____

Paper 1

Booklet A

Questions 1 to 10 carry 1 mark each. Questions 11 to 15 carry 2 marks each.

For each question, four options are given. One of them is the correct answer.

Make your choice (1, 2, 3 or 4). Shade the oval (1, 2, 3 or 4) on the Optical Answer Sheet. (20 marks)

1 In 9 783 124, the digit 7 stands for $7 \times$ _____.

- (1) 100
- (2) 1000
- (3) 10 000
- (4) 100 000

2 Spencer spent 40% of his money on a wallet and had \$240 left. How much did the wallet cost?

- (1) \$160
- (2) \$144
- (3) \$96
- (4) \$80

3 Simplify $6 + 9r - 2 + 2r$.

- (1) $7r + 4$
- (2) $7r + 8$
- (3) $11r + 4$
- (4) $11r - 8$

4 Express 1.4 hours in hours and minutes.

- (1) 1 h 4 min
 - (2) 1 h 10 min
 - (3) 1 h 24 min
 - (4) 1 h 40 min
-

5 What is the digit in the tenths place in the sum of 44.2 and 0.81?

- (1) 1
- (2) 0
- (3) 5
- (4) 4

6 Ahmad, Brayden and Kelly shared a packet of candies in the ratio of 2 : 3 : 4. Kelly had 24 candies. How many candies were there in the packet?

- (1) 72
- (2) 54
- (3) 36
- (4) 30

The line graph below shows the number of members in a fitness club from 2014 to 2018. Study the graph and answer questions 7 and 8.

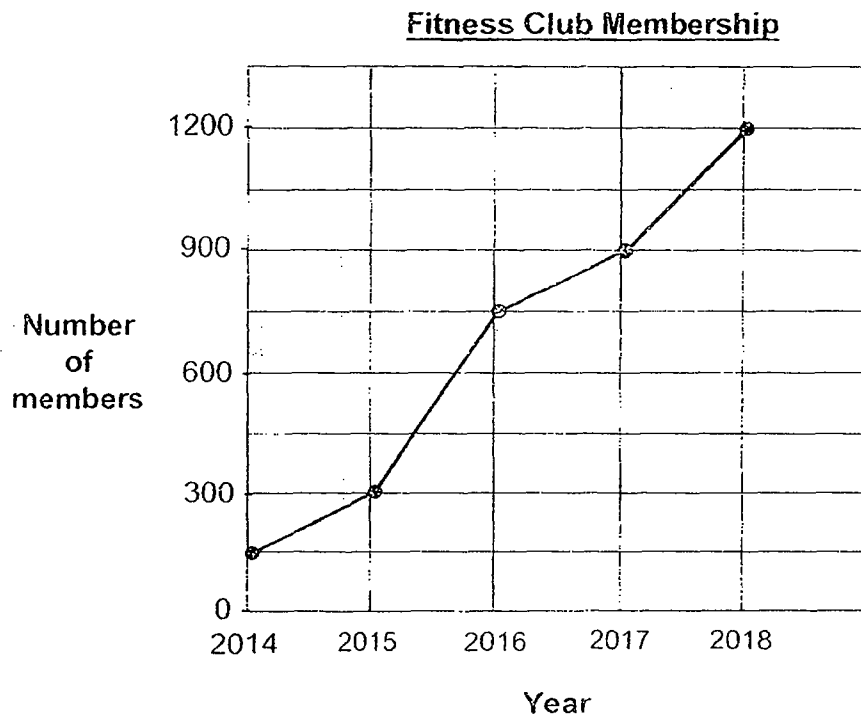

- 7 How many members were there in 2016?
- (1) 700
 - (2) 750
 - (3) 800
 - (4) 850
- 8 Between which 2 years was there a 100% increase in membership?
- (1) 2014 and 2015
 - (2) 2015 and 2016
 - (3) 2016 and 2017
 - (4) 2017 and 2018

9 Which figure below does not have any line of symmetry?

(1)

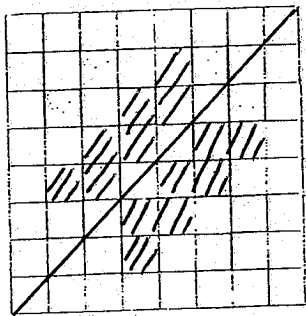

(2)

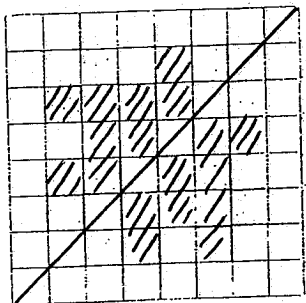

(3)

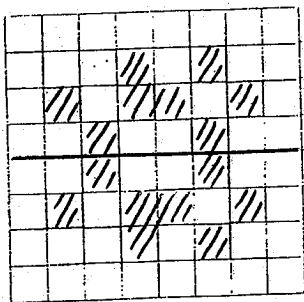

(4)

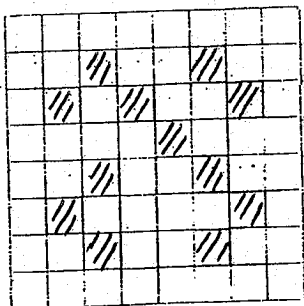

10 The solid shown is made up of identical unit cubes. Which of the following shows the front view the solid?

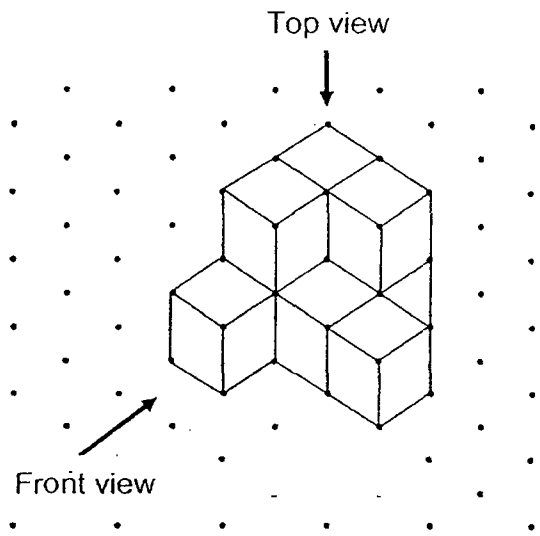
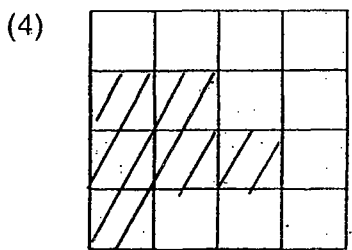
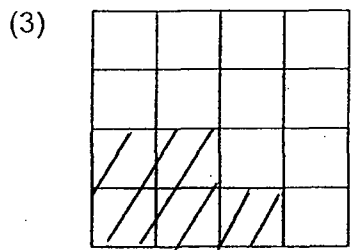
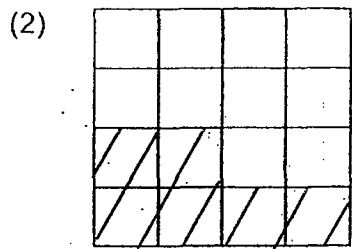
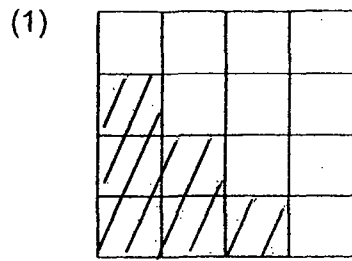

- 10 The solid shown is made up of identical unit cubes. Which of the following shows the front view the solid?

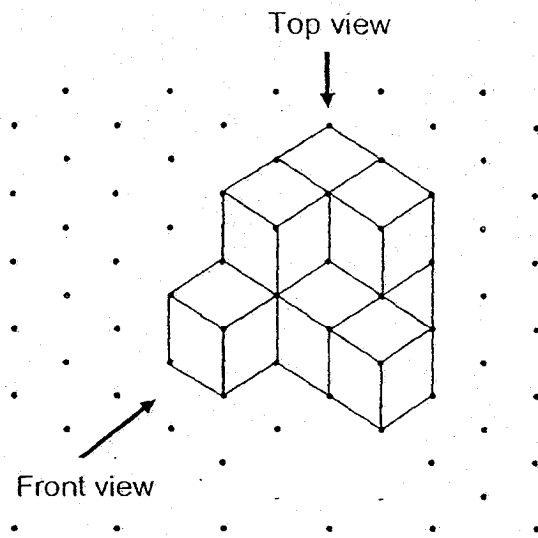
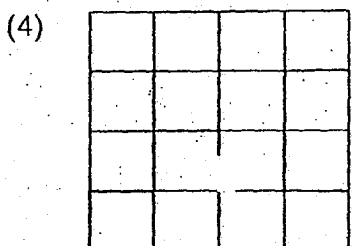
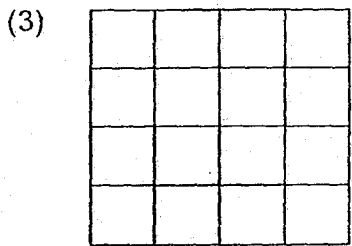
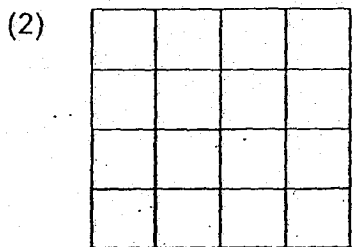
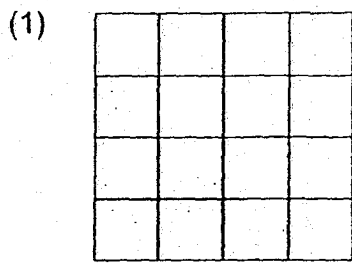

- 12 Peter is 13 years old now. His father is 3 times as old as he. What is their total age in 5 years' time?
- (1) 44 years
 - (2) 52 years
 - (3) 57 years
 - (4) 62 years
- 13 Jeff and 3 of his classmates scored an average of 80 marks in their Chinese test. If Jeff had scored 79 marks, their average score would have been 83 marks. How many marks did Jeff score?
- (1) 67
 - (2) 76
 - (3) 82
 - (4) 91
- 14 Mdm Kalsa sold 120 cupcakes in the morning and 40% of the remaining cupcakes in the afternoon. The number of cupcakes left in the end was $\frac{1}{3}$ of what she had at first. How many cupcakes were sold in the afternoon?
- (1) 40
 - (2) 60
 - (3) 150
 - (4) 270
- 15 Some students are folding paper cranes during a craft lesson. In 9 minutes, 5 students can fold 10 paper cranes. At this rate, how long does it take for 3 students to fold 54 paper cranes altogether?
- (1) 18 min
 - (2) 27 min
 - (3) 45 min
 - (4) 81 min

Paper 1
Booklet B

Questions 16 to 20 carry 1 mark each. Write your answers in the spaces provided.
For questions which require units, give your answers in the units stated.

(5 marks)

Do not write
in this space

- 16 Mr Tan sold his car for \$163 458. Round the amount to the nearest thousand dollars.

Ans: \$ _____

- 17 In the figure, AFC and BFE are straight lines. Find $\angle CFD$.

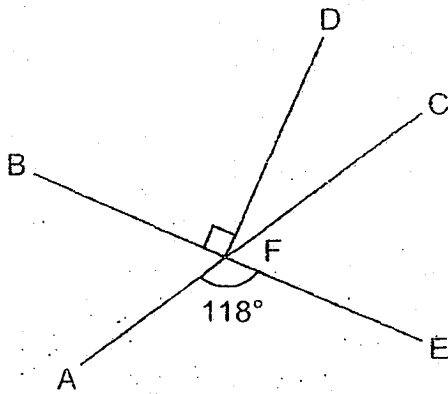

Ans: _____

- 18 Shan Shan counted a total of 50 sheep and chicken at a farm. She also counted the number of legs of these animals. Help her complete the table below correctly.

	Number of animals	Number of legs
Sheep (4 legs each)	(a) _____	(c) _____
Chicken (2 legs each)	(b) _____	24

Do not
write in
this space

- 19 Stella had \$ m . She spent $\frac{2}{5}$ of it at the bookshop.

How much money had she left?

Ans: \$ _____

20

The solid below is made up of 1-cm cubes to form the letter H.
What is the volume of the solid?

Do not write
in this space

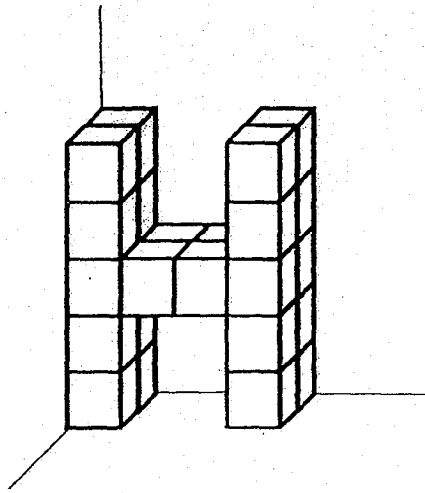

Ans: _____ cm³



Questions 21 to 30 carry 2 marks each. Show your working clearly and write your answers in the spaces provided. For questions which require units, give your answers in the units stated. (20 marks)

Do not write
in this space

- 21 Jack took $\frac{1}{2}$ h to walk 3 km at an average speed of 6 km/h, and $1\frac{1}{2}$ h to walk another 6 km at an average speed of 4 km/h. What was his average speed for the whole journey?

Ans: _____ km/h

- 22 Kate had 28 more cards than Raj at first. Then, Raj gave 12 of his cards to Kate. In the end, Kate had 3 times as many cards as Raj. How many cards did Raj have at first?

Ans: _____

23

The figure below shows a map drawn on a square grid around Kai's school.

Do not write in this space

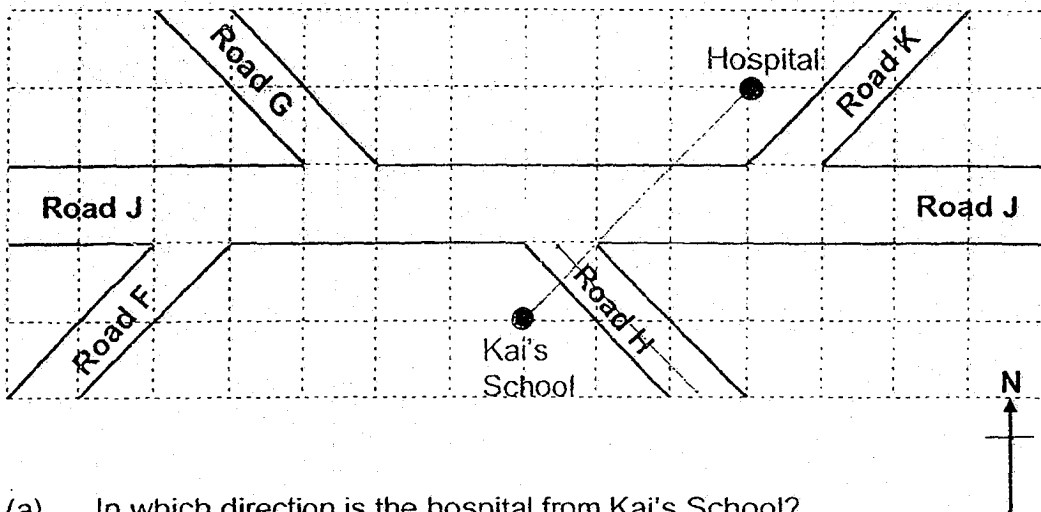

- In which direction is the hospital from Kai's School?
- Kai was walking along Road J. When he turned into another road, he faced south-east. Which road did he turn into?

Ans: (a) _____

(b) _____



24

Marcus used a piece of wire to make the figure shown below.

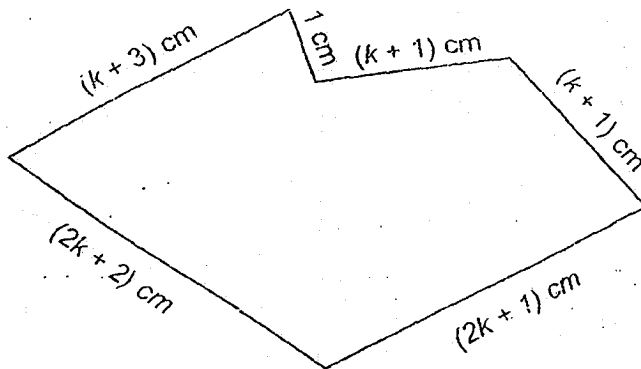

What was the length of the wire used by Marcus?
Leave your answer in the simplest form in terms of k .

Ans: _____ cm



- 25 The figure made up of three identical quarter circles and a square of side 7cm. Find the perimeter of the figure. Take $\pi = \frac{22}{7}$.

Do not write in this space

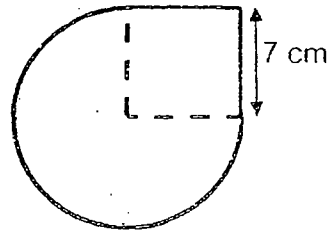

Ans: _____ cm

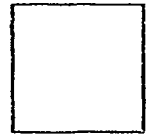

- 26 Jake's mass is $\frac{4}{7}$ of Lionel's mass. Matthew's mass is $\frac{5}{8}$ of Jake's mass.
What is the ratio of Jake's mass to Lionel's mass to Matthew's mass?

Ans: _____

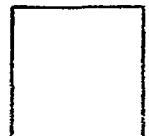

27

The pie chart below shows 3 types of vehicles that were parked in a carpark. There were 15 motorcycles. Study the pie chart to fill in the table below.

Do not write in this space

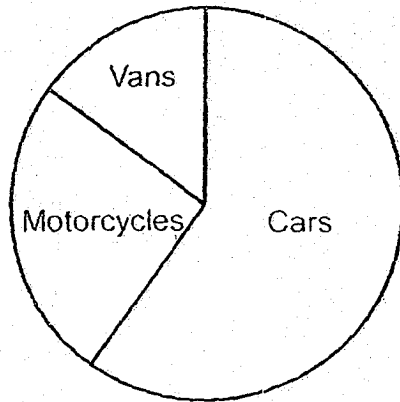

Each statement below is either true, false or not possible to tell from the information given. For each statement, put a tick (✓) in the correct column.

Statement	True	False	Not possible to tell
More than half the vehicles were cars.			
There were 10 more motorcycles than vans in the carpark.			



28

In the figure, EFGH is a parallelogram. $HJ = HK$, $\angle HJK = 75^\circ$ and $\angle HFG = 45^\circ$. Find $\angle EHJ$.

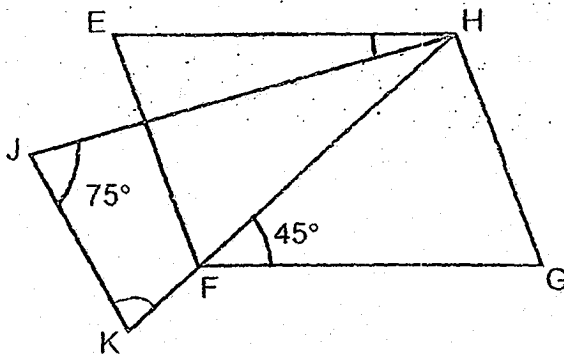

Ans: _____



29

The figure below is made up of 4 identical right-angled triangles. The shortest side of each triangle is 6 cm and the perimeter of each triangle is 32 cm. Find the perimeter of the figure.

Do not write
in this space

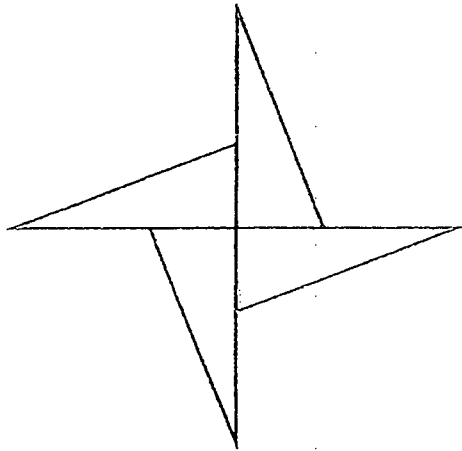

Ans: _____ cm

30

$\frac{11}{12}$ m of string is cut into shorter pieces. Each of the shorter pieces must measure $\frac{1}{6}$ m. What is the length of the remaining piece of string?

Ans: _____ m

End of Paper 1



AI TONG SCHOOL

2019

PRELIMINARY EXAMINATION

PRIMARY 6

**STANDARD MATHEMATICS
PAPER 2**

DURATION : 1 h 30 min

DATE : 23 AUGUST 2019

INSTRUCTIONS

Do not open the booklet until you are told to do so.
Follow all instructions.
Answer all questions.
You are allowed to use a calculator.

Name: _____ ()

Class: Primary 6 _____

6M _____

Marks:

Parent's Signature : _____
Date : _____

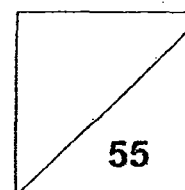

Questions 1 to 5 carry 2 marks each. Show your working clearly and write your answers in the spaces provided. For questions which require units, give your answers in the units stated. (10 marks)

Do not write in this space.

- 1 The pie chart below shows the number of visitors to a Theme Park last Saturday. There were a total of 3520 visitors. What percentage of the visitors were men?

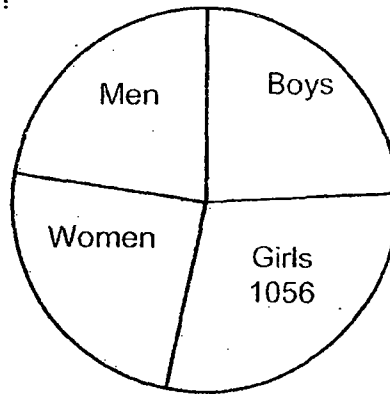

Ans: _____ %

- 2 Box A when empty has a mass of 1.8 kg. It has a mass of 21.4 kg when it contains 8 identical packets of flour and 6 identical packets of salt. Each packet of flour has a mass of 2 kg 60 g. What is the mass of each packet of salt? Give your answer in kilograms.

Ans: _____ kg

- 3 In the figure, $\triangle AOB$, $\triangle EOD$ and $\triangle DOC$ are equilateral triangles. $AE = BC$
Find $\angle ABC$.

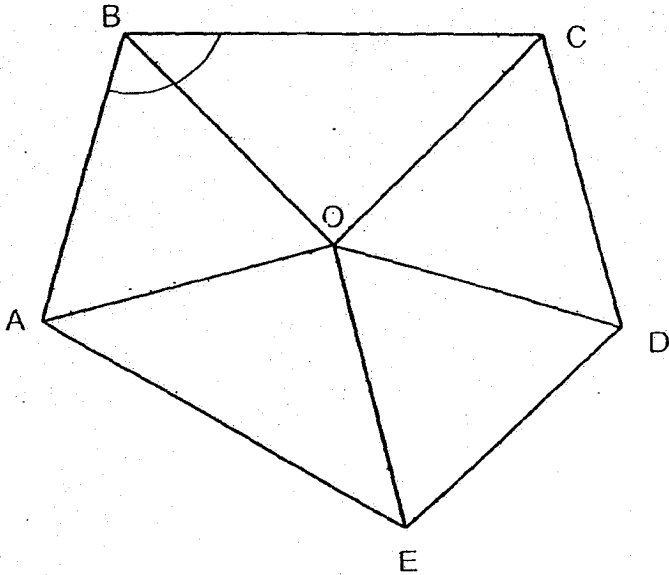

Ans: _____

Do not write
in this space.



- 4 In the figure below, $\triangle ABC$ and $\triangle XYZ$ are identical right-angled triangles. The total area of the shaded parts is 130 cm^2 . Find the area of the unshaded part.

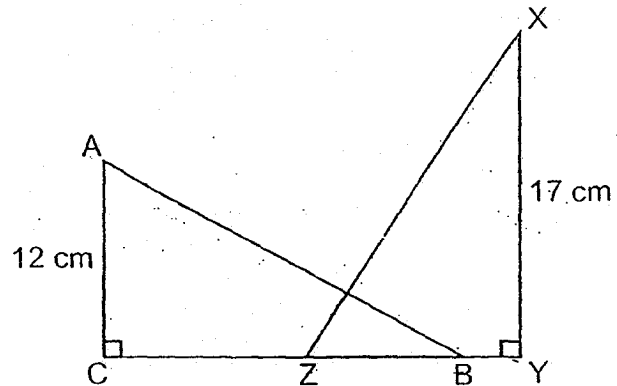

Ans: _____ cm^2



5 A piece of paper in the shape of a rhombus is folded along the dotted line as shown. Find $\angle y$.

Do not write in this space.

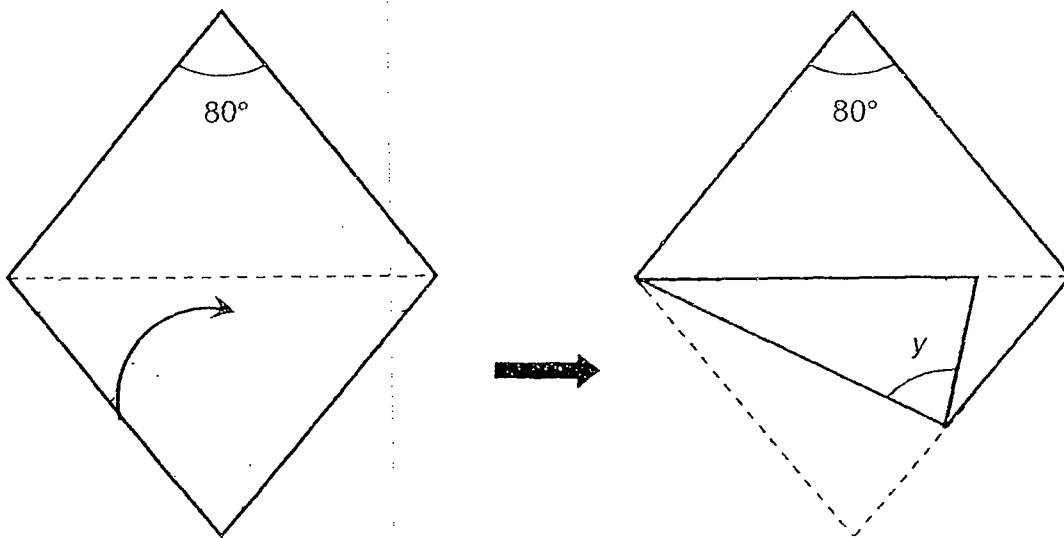

Ans: _____



For questions 6 to 17, show your working clearly and write your answers in the spaces provided. The number of marks available is shown in bracket [] at the end of each question or part-question. For questions which require units, give your answers in the units stated

Do not write in this space

(45 marks)

6 In the square grid, WX and XY are two sides of a trapezium. WX is parallel to ZY. WX is twice the length of ZY.

- (a) Complete the drawing of trapezium WXYZ. Label Z.
- (b) Measure and write down the size of $\angle XWZ$.

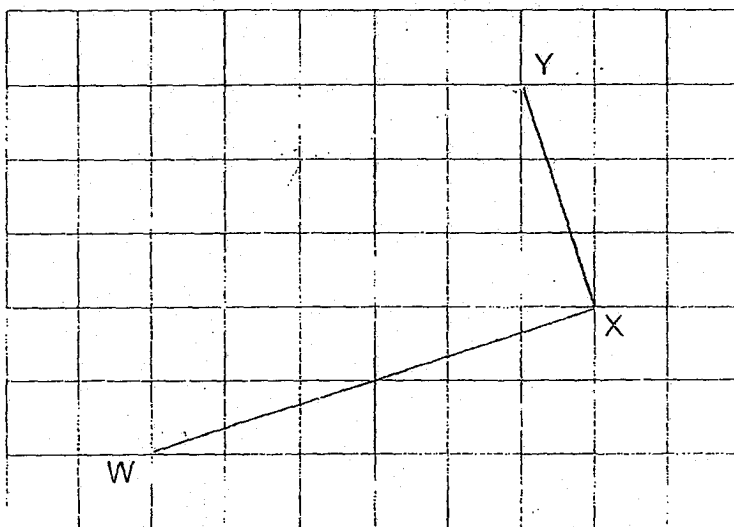

[2]

Ans: (b) _____ [1]

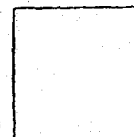

- 7 The graph below shows the number of students in five different schools in 2019. The number of students is not shown on the scale.

Do not write in this space

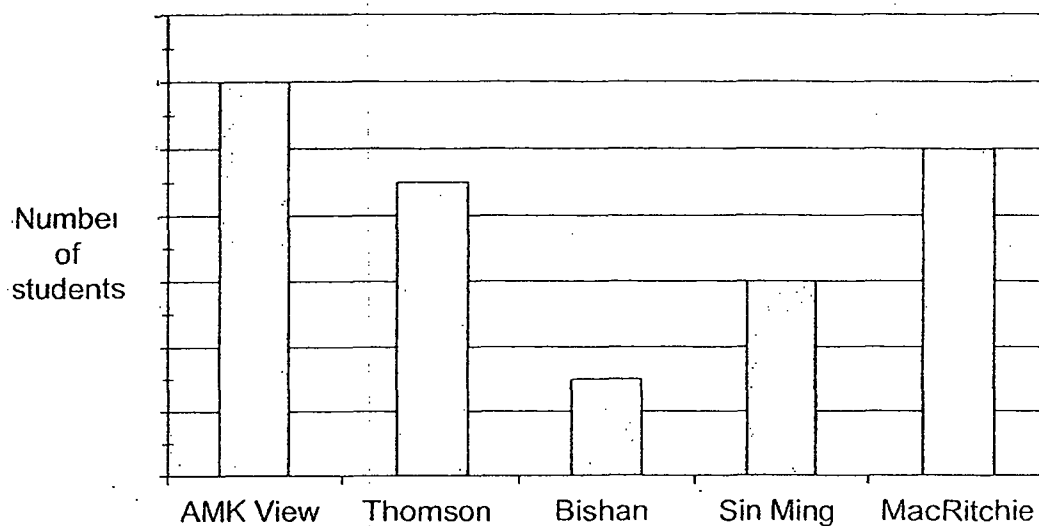

The same data is partially shown in the pie chart below:

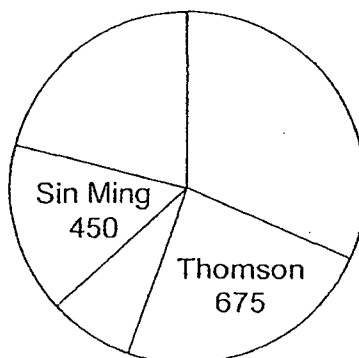

- (a) The total enrolment of two of the schools is equal to the enrolment of AMK View School. Which two schools are these?
- (b) How many students are there in MacRitchie School?

Ans : (a) _____ and _____ [1]

(b) _____ [2]

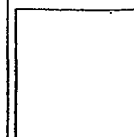

- 8 Four identical circles, each of radius 16 cm, are touching each other as shown. The dotted lines join the centres of the circles to form a square. Find the area of the shaded part. Take $\pi = 3.14$.

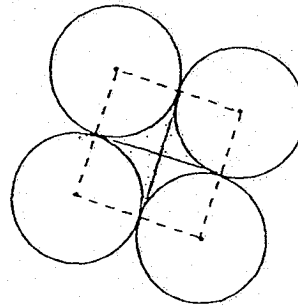

Do not write
in this space.

Ans: _____ [3]

- 9 Pete and Dave started driving at the same time from the same place but in opposite directions along a straight road. After 3h, they were 510.3 km apart. Pete's average speed was 11.2 km/h faster than Dave's average speed. What was Dave's average speed?

Ans: _____ [3]

10 At the Home Appliance Warehouse Sale, Mr Chua bought a vacuum cleaner and a washing machine for a total of \$2980 after discount. He paid \$464 more for the washing machine than the vacuum cleaner.

Do not write
in this space

- (a) Find the percentage discount given for the vacuum cleaner.
- (b) Find the usual price of the washing machine.



Vacuum Cleaner
Usual price: \$1480
Discount: 



Washing Machine
Discount: 20%

Ans: (a) _____ [2]

(b) _____ [2]

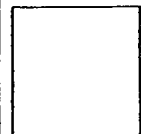

- 11 The number of boys and girls in a hall was in the ratio 4 : 5.
After 170 boys and 20% of the girls went back to their classrooms, the
ratio of the number of boys to the number of girls in the hall became 1 : 2.
How many children were there in the hall in the end?

Do not write
in this space.

Ans: _____ [3]

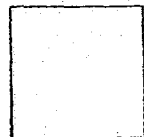

12 Eddy sold phone cards during a part-time holiday job. For every phone card sold, he would receive \$0.60. For every 20 phone cards sold, he would receive an additional \$4.50.

- (a) How much did he receive after selling 20 phone cards?
- (b) How many phone cards did Eddy need to sell to receive at least \$150?

Do not write
in this space.

Ans: (a) _____ [1]

(b) _____ [3]

- 13 A rectangular tank measures 60 cm by 30 cm by 34 cm. It is divided into two parts by a piece of plastic PQRS that is 2 cm thick. One part of the container contains water to a depth of 31 cm. When the piece of plastic PQRS is removed, what is the height of the water level in the tank? Give your answer correct to 1 decimal place.

Do not write in this space.

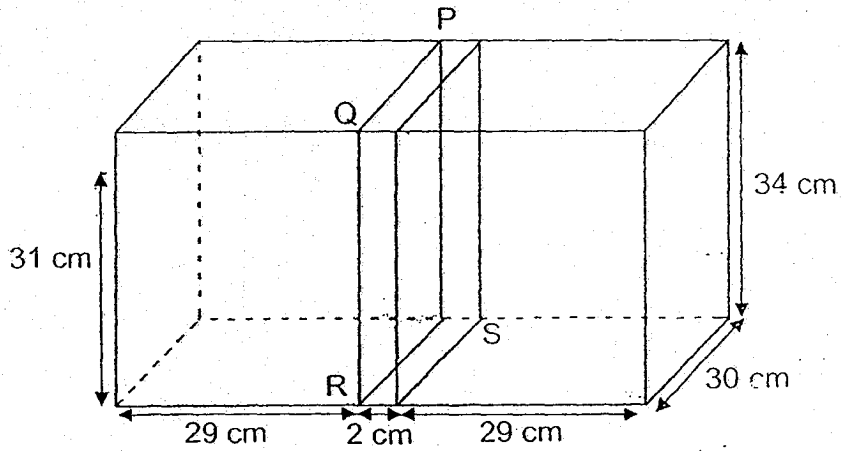

Ans: _____ [4]

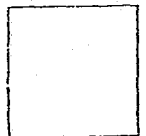

- 14 In the figure, RSTU is a square. $TU = TP$ and $\angle RQS = 103^\circ$. Find $\angle PTU$.

Do not write in this space.

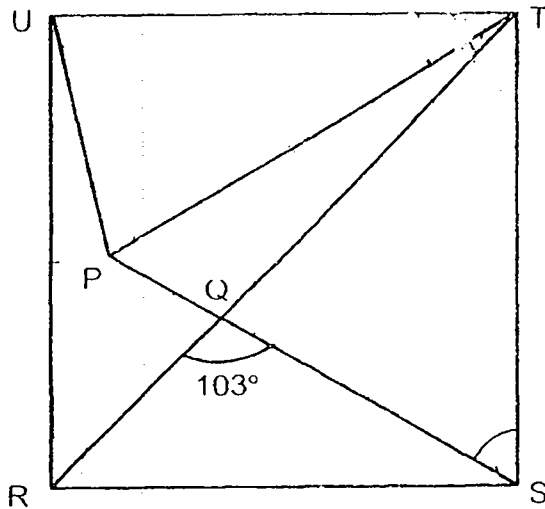

Ans: _____ [4]

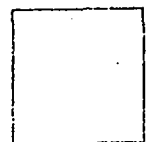

- 15 Three girls had 144 sweets altogether. Aileen gave some of her sweets to Betty and Betty's sweets were doubled. Then, Betty gave some of her sweets to Catty and Catty's sweets were doubled. As a result, the three girls had an equal number of sweets each. How many sweets did Betty have at first?

Do not write
in this space.

Ans: _____ [4]

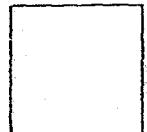

16 The figures in the pattern below are made up of dots.

Do not write
in this space.

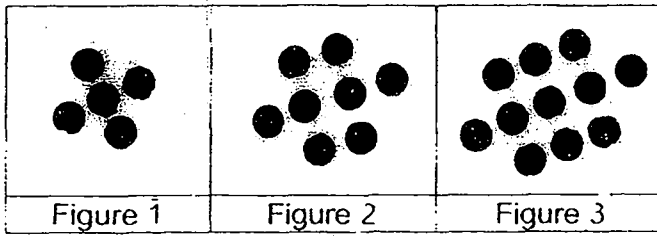

- (a) How many dots are required to form the Figure 5?
- (b) Write down the number of dots in the Figure 50.
- (c) Which Figure has 269 dots?

Ans: (a) _____ [1]

(b) _____ [2]

(c) _____ [2]



17 Mrs Sim sold some tennis rackets and badminton rackets for \$17 043.
Each tennis racket cost \$273 and each badminton racket cost $\frac{3}{7}$ as much
as the tennis racket. $\frac{2}{5}$ of the rackets sold were tennis rackets.

- (a) How much did each badminton racket cost?
- (b) How many badminton rackets were sold?

Do not write
in this space.

Ans: (a) _____ [1]

(b) _____ [4]



END OF PAPER
CHECK YOUR WORK CAREFULLY !

SCHOOL : AI TONG PRIMARY SCHOOL
 LEVEL : PRIMARY 6
 SUBJECT : MATH
 TERM : 2019 PRELIM

CONTACT : CALL MR GAN @ 9299 8971, 8606 5443

PAPER 1 BOOKLET A

Q 1	Q2	Q3	Q4	Q5	Q6	Q7	Q8	Q9	Q10
4	1	3	3	2	2	2	1	4	3

Q 11	Q12	Q13	Q14	Q15
2	4	1	2	4

PAPER 1 BOOKLET B

Q16)	\$163000
Q17)	28°
Q18)	a)38 b)12 c)152
Q19)	$\$(\frac{3m}{5})$
Q20)	24cm ³
Q21)	3 + 6 = 9 $\frac{1}{2} + 1\frac{1}{2} = 2$ 9 ÷ 2 = 4.5km/h
Q22)	2u → 12 + 28 + 12 = 52 1u → 26 26 + 12 = 38

Q23)	a)North-east b)Road H
Q24)	$(7k + 9)\text{cm}$
Q25)	$\frac{3}{4} \times \frac{22}{7} = \frac{66}{28}$ $= \frac{33}{14}$ $\frac{33}{14} \times \frac{14}{1} = \frac{33}{1}$ $= 33$ $33 + 7 + 7 = 47$
Q26)	$8 : 14 : 5$
Q27)	True Not possible to tell
Q28)	$75 + 75 = 150$ $180 - 150 = 30$ $45 - 30 = 15^\circ$
Q29)	$32 - 6 = 26$ $26 - 6 = 20$ $20 \times 4 = 80 \text{ cm}$
Q30)	$\frac{11}{12} \div \frac{1}{6} = \frac{11}{12} \times \frac{6}{1} = \frac{11}{2}$ $= 5\frac{1}{2}$ $\frac{1}{2} \times \frac{1}{6} = \frac{1}{12} \text{ m}$

PAPER 2

Q1)	$3520 \div 2 = 1760$ $1760 - 1056 = 704$ $\frac{704}{3520} = \frac{1}{5} = \frac{20}{100} = 20\%$
Q2)	$21.4 - 1.8 = 19.6$ $2.06 \times 8 = 16.48$ $19.6 - 16.48 = 3.12$ $3.12 \div 6 = 0.52\text{kg}$

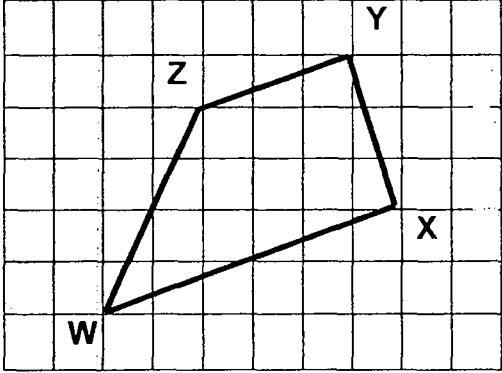
Q3)	$360^\circ - 60^\circ - 60^\circ - 60^\circ = 180^\circ$ $180^\circ \div 2 = 90^\circ$ $180^\circ - 90^\circ = 90^\circ$ $90^\circ \div 2 = 45^\circ$ $45^\circ + 60^\circ = 105^\circ$
Q4)	$\frac{1}{2} \times 12 \times 17 = 102$ $102 + 102 = 204$ $204 - 130 = 74$ $74 \div 2 = 37\text{cm}^2$
Q5)	$180^\circ - 80^\circ = 100^\circ$ $100^\circ \div 2 = 50^\circ$ $50^\circ \div 2 = 25^\circ$ $180^\circ - 80^\circ - 25^\circ = 75^\circ$
Q6)	<p>a)</p>  <p>b) 45°</p>
Q7)	$675 - 450 = 225$ $225 \div 3 = 75$ $225 + 675 = 900$ a) Thomson and Bishan b) 750
Q8)	$16 + 16 = 32$ $32 \times 32 = 1024$ $3.14 \times 16 \times 16 = 803.84$ $1024 - 803.84 = 220.16 \text{ cm}^2$
Q9)	$11.2 \times 3 = 33.6$ $510.3 - 33.6 = 476.7$ $476.7 \div 2 = 238.35$ $238.35 \div 3 = 79.45 \text{ km/h}$

Q10)	<p>a) $2980 - 464 = 2516$ $2516 \div 2 = 1258$ $85\% \times 1480 = 1258$ $100 - 85 = 15\%$</p> <p>b) $2980 - 1258 = 1722$ $80\% \rightarrow \\$1722$ $100\% \rightarrow \\$2152.50$</p>
Q11)	<p>B : G 4u : 5u <u>-170 : - 1u (20% x 5u)</u> (2u)1p: 2p(4u) \rightarrow 6u (whole thing)</p> <p>1p = 4u - 170 2p = 8u - 340 4u = 8u - 340 1u = 85 6u = 510</p>
Q12)	<p>$0.6 \times 20 = 12$ $12 + 4.5 = 16.5$ $16.5 \times 9 = 148.5$ $148.5 + 0.6 + 0.6 + 0.6 = 150.3$ $20 \times 9 = 180$ $180 + 3 = 183$</p> <p>a) \$16.50 b) 183</p>
Q13)	<p>$60 \times 30 \times 34 = 61200$ $2 \times 30 \times 34 = 2040$ $31 \times 29 \times 30 = 26970$ $60 \times 30 = 1800$ $26970 \div 1800 \approx 15.0 \text{ cm}$</p>
Q14)	<p>$180 - 103 = 77$ $180 - 103 - 45 = 32$ $90 - 32 = 58$ $180 - 58 - 58 = 64$ $90 - 64 = 26^\circ$</p>

<p>Q15)</p>	<div style="text-align: center;"> </div> <p style="text-align: center;"> $12u \rightarrow 144$ $3u \rightarrow 36$ </p>
<p>Q16)</p>	<p>a) $5 + 2 = 7$ $5 + 5 + 7 = 17$ b) $50 + 2 = 52$ $50 + 50 + 52 = 152$ c) $269 - 2 = 267$ $267 \div 3 = 89$ (figure 89)</p>
<p>Q17)</p>	<p>a) $\frac{3}{7} \times 273 = \\117 b) $273 + 273 + 117 + 117 + 117 = 897$ $17043 \div 897 = 19$ $19 \times 3 = 57$</p>





HENRY PARK PRIMARY SCHOOL
2019 PRELIMINARY EXAMINATION
MATHEMATICS
PRIMARY 6

PAPER 1
(BOOKLET A)

Name: _____ ()

Parent's Signature

Class: Primary 6 _____

Marks:

Paper 1	Booklet A	20
	Booklet B	25
Paper 2		55
Total		100

Total Time for Booklets A and B: 1 hour

Do not turn over this page until you are told to do so.

Follow all instructions carefully.

Answer all questions.

Shade your answers in the Optical Answer Sheet (OAS) provided.

You are **not** allowed to use a calculator.

Questions 1 to 10 carry 1 mark each. Questions 11 to 15 carry 2 marks each.
For each question, four options are given. One of them is the correct answer.
Make your choice (1, 2, 3 or 4) and shade your answer in the Optical Answer Sheet.

(20 marks)

1 What does the digit 9 in 6.789 stand for?

- (1) 9 thousandths
- (2) 9 hundredths
- (3) 9 tens
- (4) 9 ones

2 Express $10k + 8 - 2k - 3$ in the simplest form.

- (1) $5k + 8$
- (2) $8k + 5$
- (3) $12k + 5$
- (4) $16k - 3$

3 In a class of 40 students, 15% of them do not wear spectacles.
How many students wear spectacles?

- (1) 6
- (2) 15
- (3) 25
- (4) 34

- 4 The figure shows a circle with diameter 22 cm.
Find the area of the circle in terms of π .

- (1) $11\pi \text{ cm}^2$
- (2) $22\pi \text{ cm}^2$
- (3) $121\pi \text{ cm}^2$
- (4) $282\pi \text{ cm}^2$

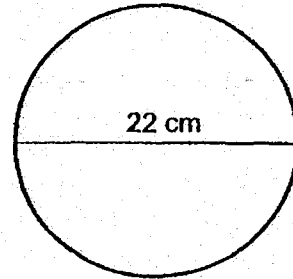

- 5 What is the perimeter of the figure shown below?

- (1) 26 cm
- (2) 39 cm
- (3) 43 cm
- (4) 44 cm

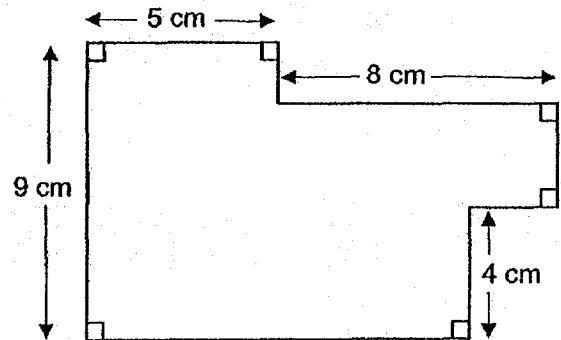

- 6 Four letters are shown on the square grid below.

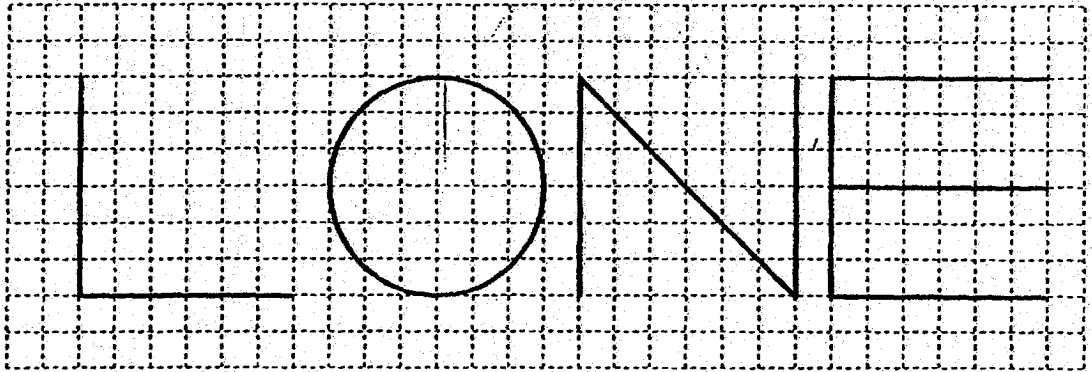

How many of the letters above is/are **NOT** symmetrical?

- (1) 1
 - (2) 2
 - (3) 3
 - (4) 4
- 7 A number when divided by 20 gives a remainder of 6. Which of the following can be added to the number to change it to a multiple of 8?

- (1) 10
- (2) 7
- (3) 5
- (4) 4

Use the information below to answer Questions 8 and 9.

The line graph below shows the number of tourists who visited Country X from 2014 to 2018.

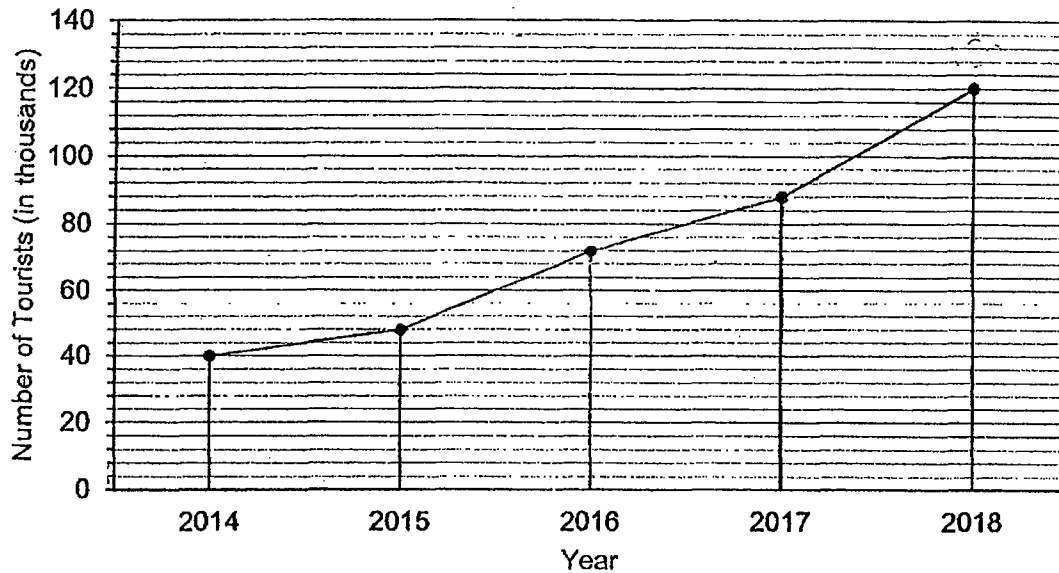

8 In which of the following periods did the number of tourists increase the most?

- (1) 2014 to 2015
- (2) 2015 to 2016
- (3) 2016 to 2017
- (4) 2017 to 2018

9 The number of tourists in 2019 was a 20% decrease from the number of tourists in 2018. How many tourists (in thousands) visited Country X in 2019?

- (1) 24
- (2) 90
- (3) 96
- (4) 100

- 10 The figure shows a cube. Two faces of the cube were shaded and the remaining faces were white.

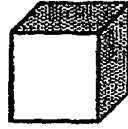

Which one of the following is NOT the net of the cube?

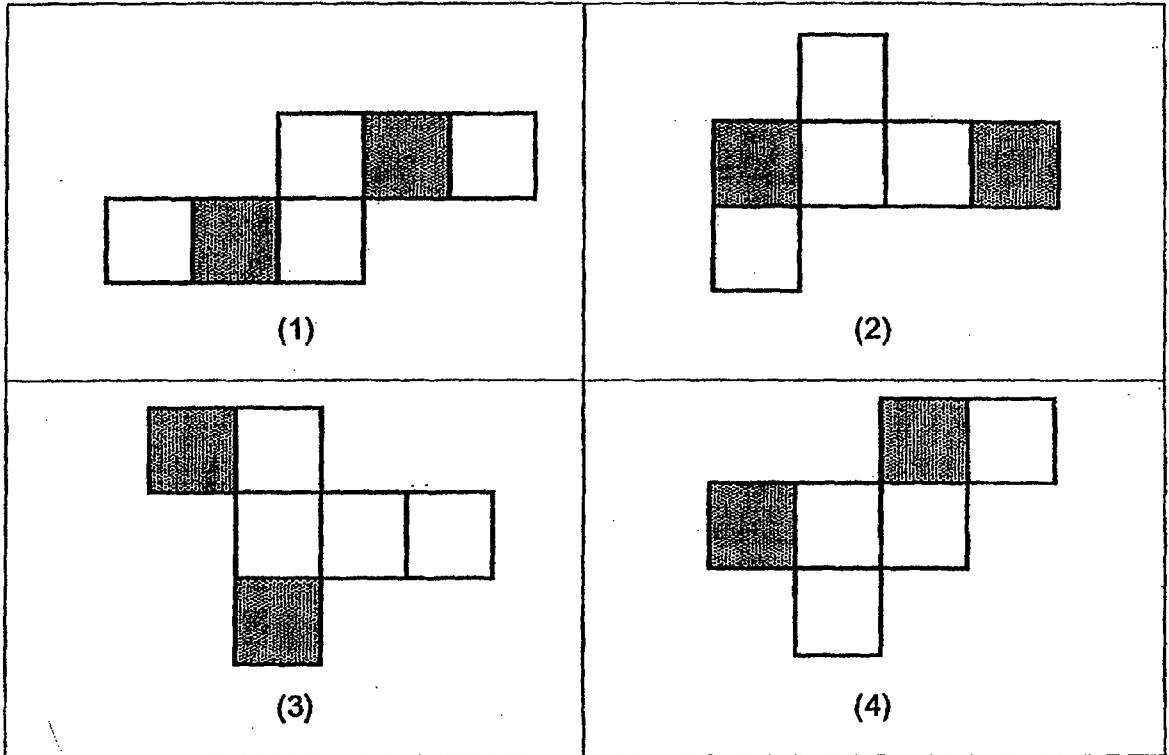

- 11 The table below shows the number of books read by 37 students in August. The number of students who read 5 books were not shown in the table.

Number of books	1	2	3	4	5
Number of students	10	8	7	9	?

How many students read at least 3 books in August?

- (1) 7
 - (2) 16
 - (3) 19
 - (4) 25
- 12 Five attractions on a map of a town are shown in the square grid below.

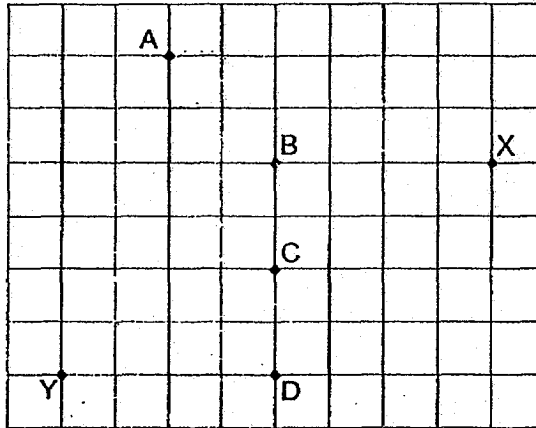

Mike is at one of the attractions. He is facing X. When he turns 135° clockwise, he faces Y. Which attraction is Mike at?

- (1) A
- (2) B
- (3) C
- (4) D

- 13 The bar graph shows the number of stamps from four different countries that Peter collected.

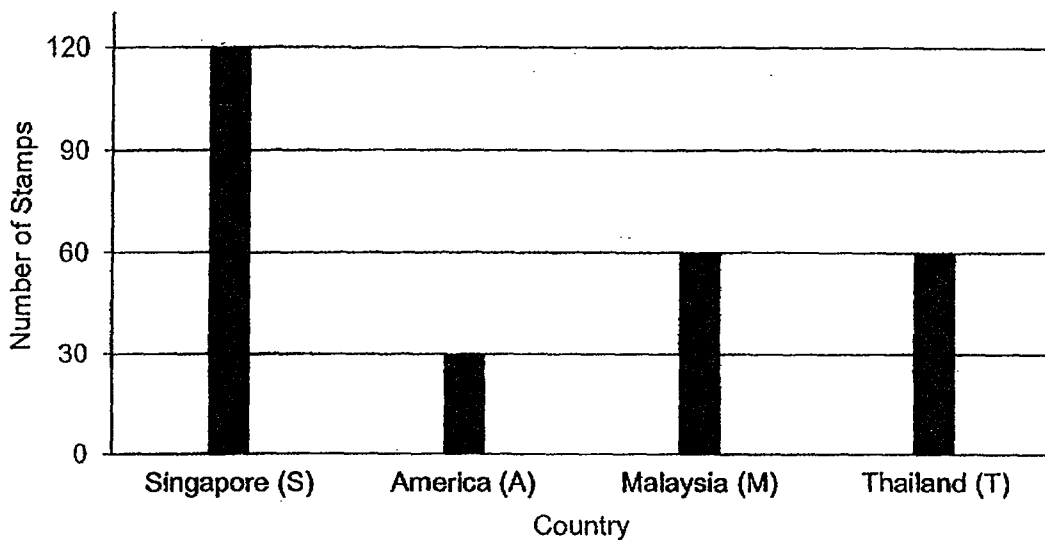

Which pie chart best represents the information in the bar graph?

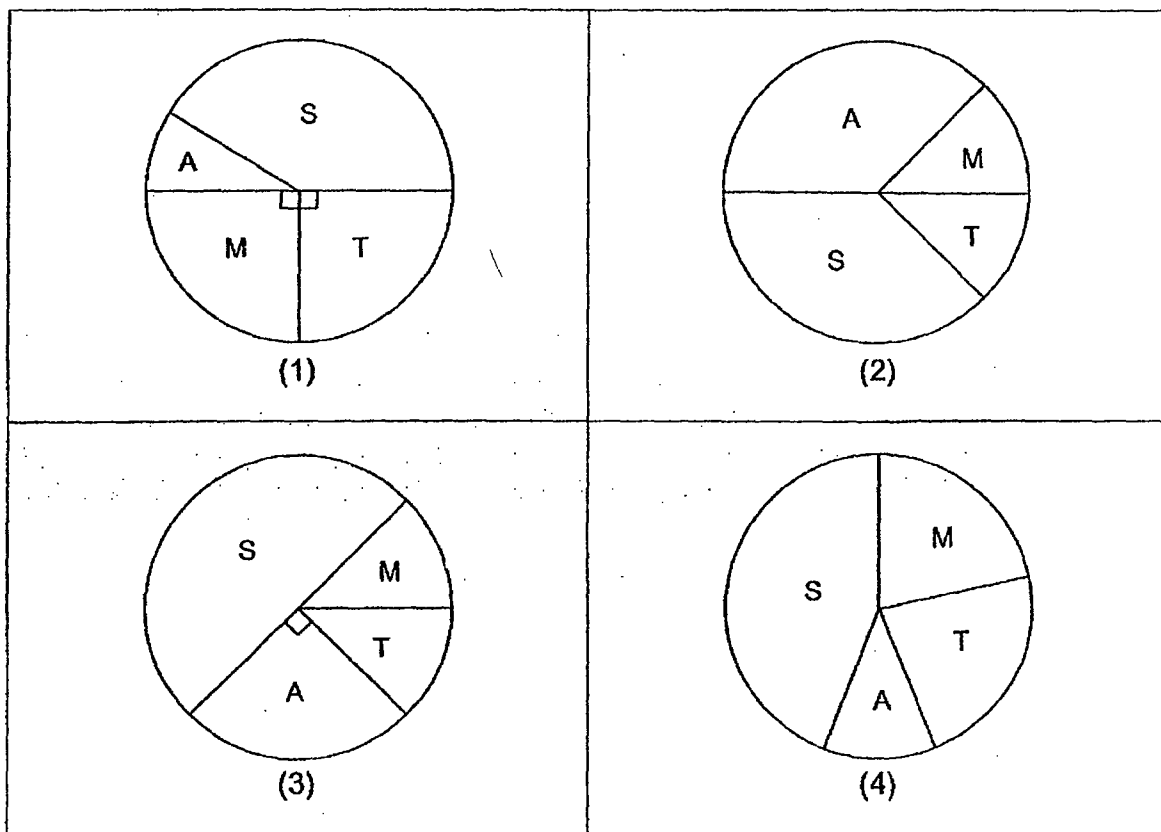

- 14 Calista and Dylan had the same number of stickers at first.
After Calista gave $\frac{1}{8}$ of her stickers to Dylan, she had 24 fewer stickers than Dylan.
How many stickers did Calista and Dylan have altogether?

- (1) 84
- (2) 96
- (3) 192
- (4) 216

- 15 Jane packed 408 cupcakes into a number of boxes.
Each box contained either 10 or 6 cupcakes.
Given that Jane used the least number of boxes to pack all the cupcakes, how many of the boxes contained 10 cupcakes each?

- (1) 25
- (2) 26
- (3) 39
- (4) 40

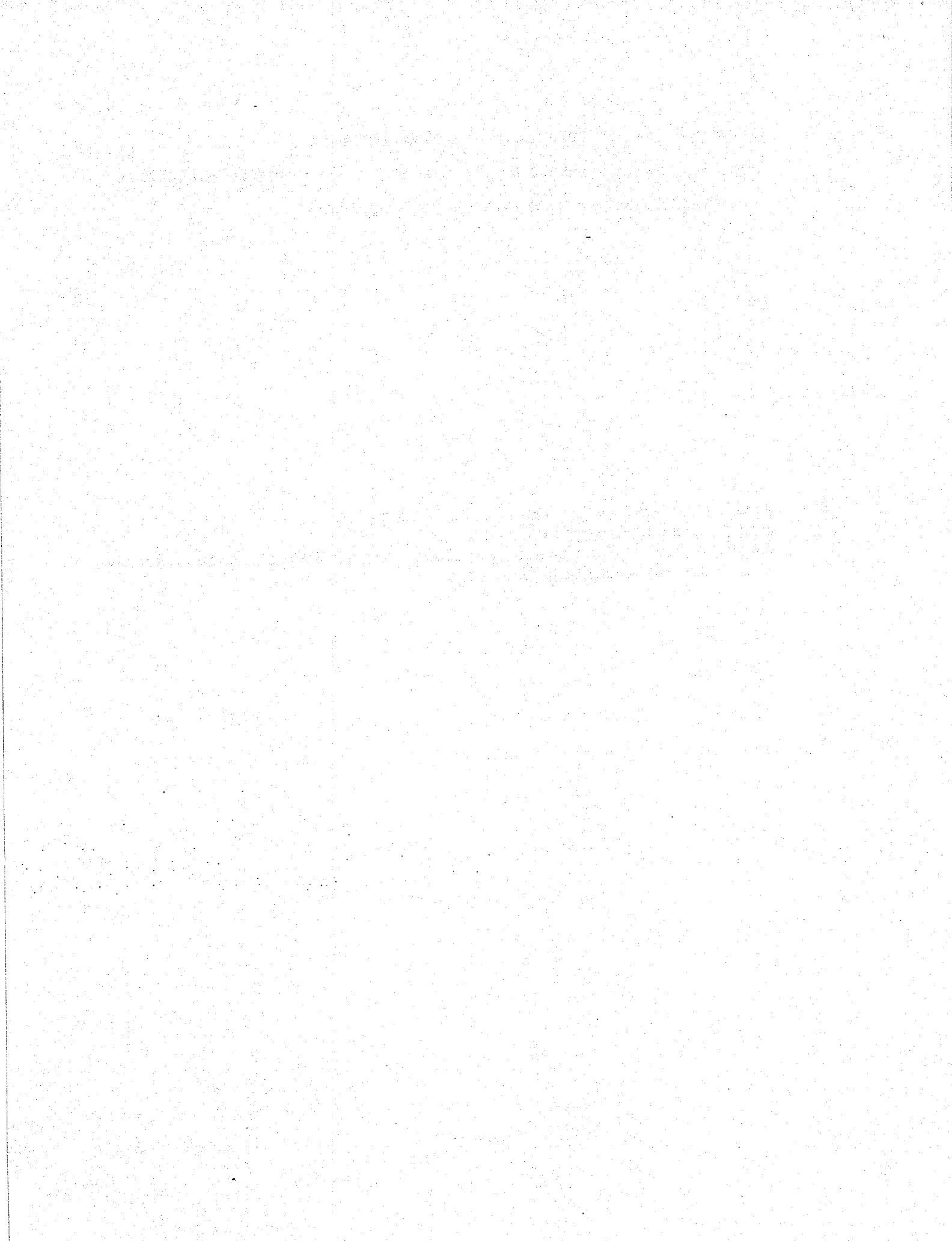



HENRY PARK PRIMARY SCHOOL
2019 PRELIMINARY EXAMINATION
MATHEMATICS
PRIMARY 6

PAPER 1
(BOOKLET B)

Name: _____ ()

Class: Primary 6 _____

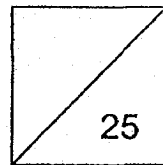

Total Time for Booklets A and B: 1 hour

Do not turn over this page until you are told to do so.

Follow all instructions carefully.

Answer all questions.

Write your answers in this booklet.

You are not allowed to use a calculator.

Questions 16 to 20 carry 1 mark each. Write your answers in the spaces provided.
For questions which require units, give your answers in the units stated.

(5 marks)

Do not write
in this space

16 Find the value of $108.5 + 1.99$

Ans: _____

17 Express $5\frac{2}{25}$ as a decimal.

Ans: _____

18 Find the value of $7a + \frac{28 - 2a}{5}$ when $a = 9$

Ans: _____

- 19 Janet thought of a number with 2 decimal places. When she rounded it to the nearest whole number, it became 37. What was the greatest possible number that Janet could have thought of?

Do not write
in this space

Ans: _____

- 20 Find the average of the following list of numbers:

Ans: _____

Questions 21 to 30 carry 2 marks each. Show your working clearly and write your answers in the spaces provided. For questions which require units, give your answers in the units stated.

Do not write in this space

(20 marks)

21 List all the common factors of 14 and 35

Ans: _____

22 The figure below is drawn on a square grid.

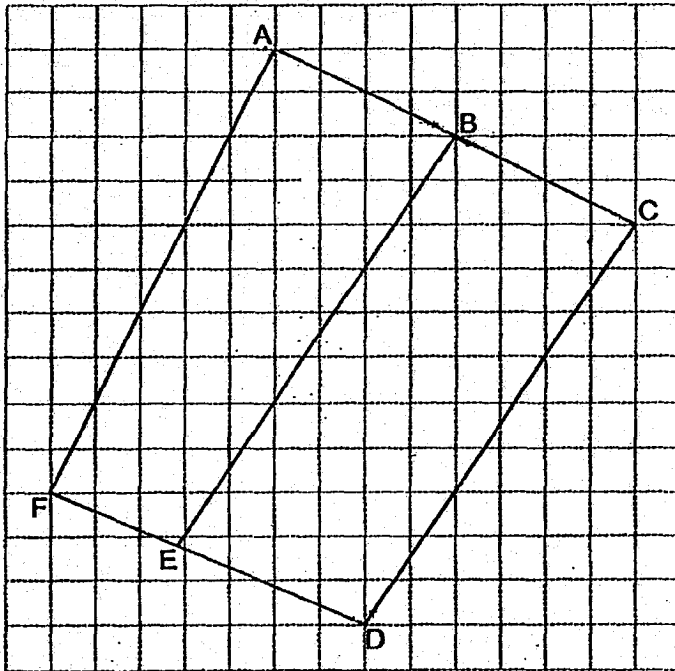

- (a) Name two lines that are parallel to each other.
- (b) Name two lines that are perpendicular to each other.

Ans: (a) _____ and _____

(b) _____ and _____

- 23 The opening hours of a gym are shown below.

Do not write
in this space

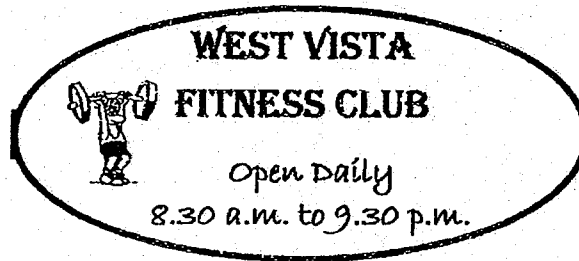

- (a) How long is the gym open each day?
- (b) Mrs Ling spent 1 h 45 min at the gym. Given that she finished her workout at 5.25 p.m., what time did she start her workout?

Ans: (a) _____ h

(b) _____ p.m.

- 24 In the figure, PQ and RS are straight lines. Find $\angle z$.

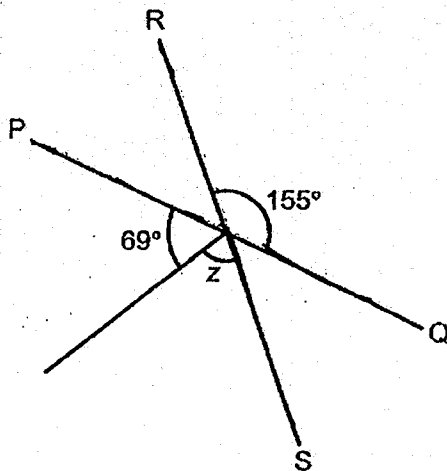

Ans: _____ °

- 25 Find the area of the shaded part of the figure.

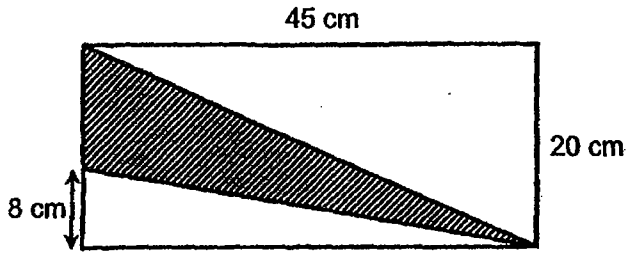

Ans: _____ cm²

Do not write
in this space

- 26 The bar graph shows the number of funfair tickets sold by a group of students. The bar showing the number of students who sold 3 tickets each is not shown. Given that $\frac{3}{8}$ of the students sold 3 tickets each, find the number of students who sold 3 tickets each.

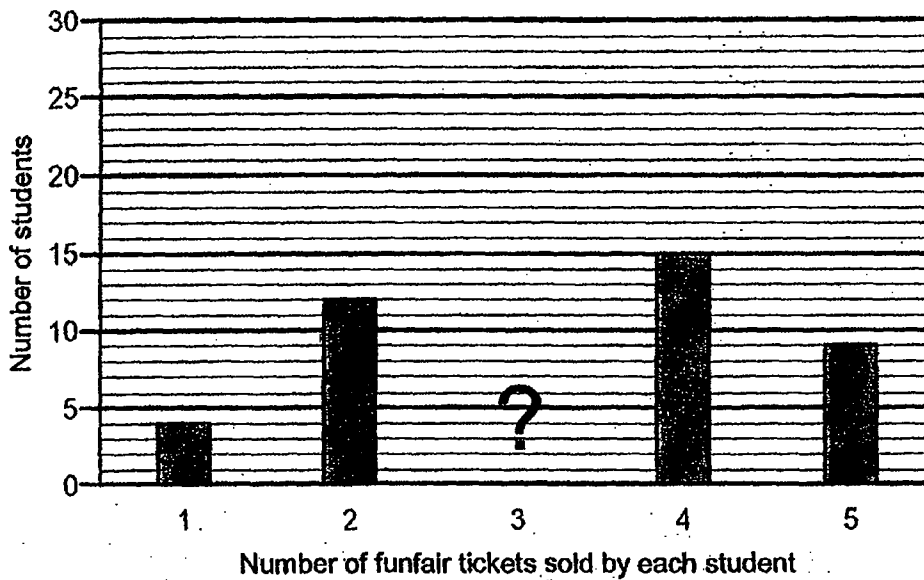

Ans: _____

- 27 The rectangular tank shown below is $\frac{2}{3}$ -filled with water. The base area of the tank is 120 cm^2 . Given that it contained 2.4 litres of water, what is the height of the container?

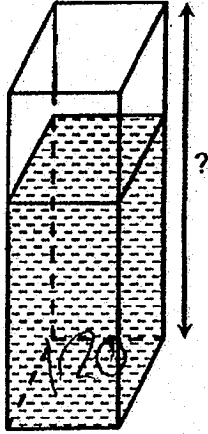

Ans: _____ cm

Do not write
in this space

- 28 In the figure, ABCD and AEFG are identical rhombuses, $\angle BAG = 75^\circ$ and $\angle EFG = 65^\circ$. Find $\angle ABE$.

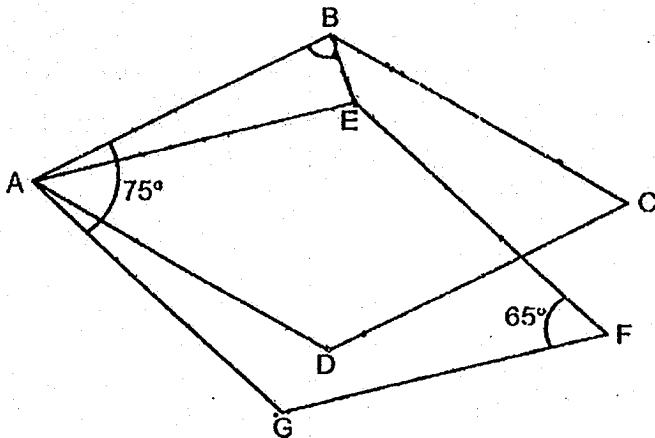

Ans: _____ °

- 29 The table below shows how much a shop charges a customer for renting an electric scooter.

Do not write
in this space

First 1 hour	\$12
Every additional $\frac{1}{2}$ hour	\$4

Ayomi paid \$36 for renting an electric scooter starting from 07 30
What would be the latest time that she must return the scooter to the shop?
Express your answer using the 24-hour clock.

Ans: _____

- 30 The figure shows two circles. The ratio of the diameter of the small circle to the diameter of the large circle is 1 : 2. The area of the small circle is 42 cm^2 .
What is the area of the shaded part of the figure?

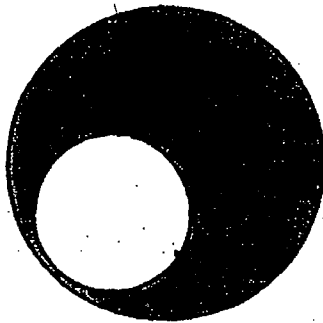

Ans: _____ cm^2



HENRY PARK PRIMARY SCHOOL
2019 PRELIMINARY EXAMINATION
MATHEMATICS
PRIMARY 6

PAPER 2

Parent's Signature

Name: _____ ()

Class: Primary 6 _____

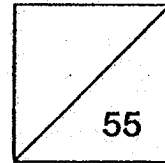

Time for Paper 2: 1 hour 30 minutes

Do not turn over this page until you are told to do so.

Follow all instructions carefully.

Answer all questions.

Show your working clearly as marks are awarded for correct working.

Write your answers in this booklet.

You are allowed to use a calculator.

Questions 1 to 5 carry 2 marks each. Show your working clearly and write your answers in the spaces provided. For questions which require units, give your answers in the units stated.

Do not write in this space

(10 marks)

1 Joanne had a ribbon measuring 18 m in length. She cut the ribbon into shorter pieces, each measuring $\frac{4}{5}$ m.

- (a) What would be the most number of $\frac{4}{5}$ -m pieces that she could cut?
(b) What would be the length of the ribbon left in the end?

Ans: (a) _____

(b) _____ m

2 The numbers on Card X and Card Y are 3-digit numbers. The first digit on Card Y is shown below.

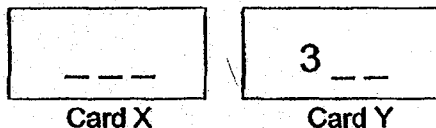

Given that the average of the two numbers on Card X and Card Y is 300, find the smallest possible number on Card X.

Ans: _____

- 3 A piece of paper in the shape of a parallelogram is folded along the dotted line as shown below. Find $\angle y$

Do not write
in this space

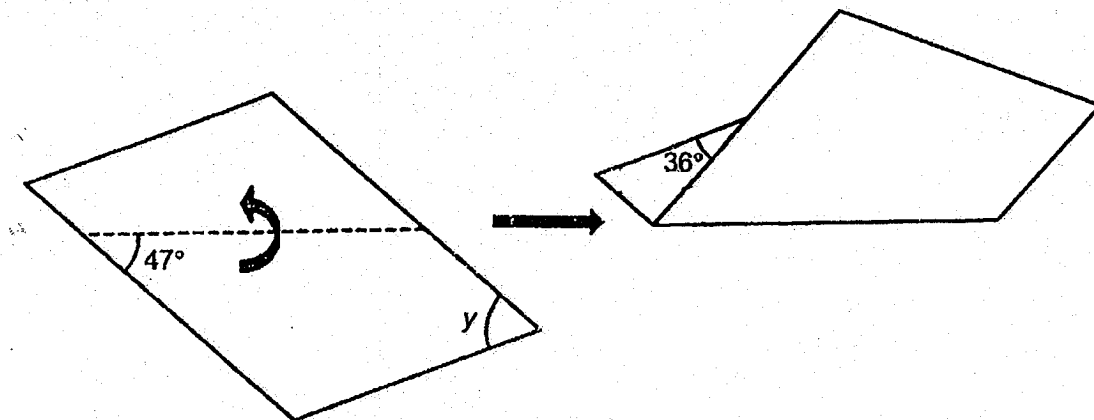

Ans: _____ °

- 4 In the figure below, JKLM is a square, $\angle MLO = 11^\circ$ and $KL = KO$. Find $\angle JOK$.

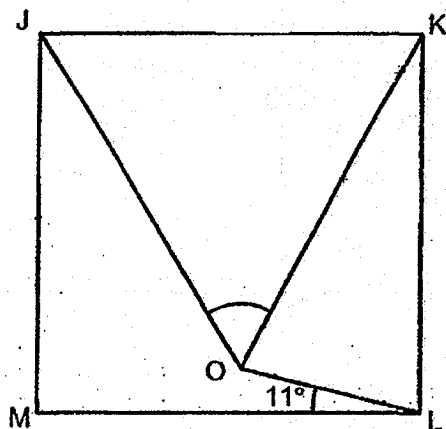

Ans: _____ °

5 Two lines, AB and AC, are drawn inside a box.

Do not write
in this space

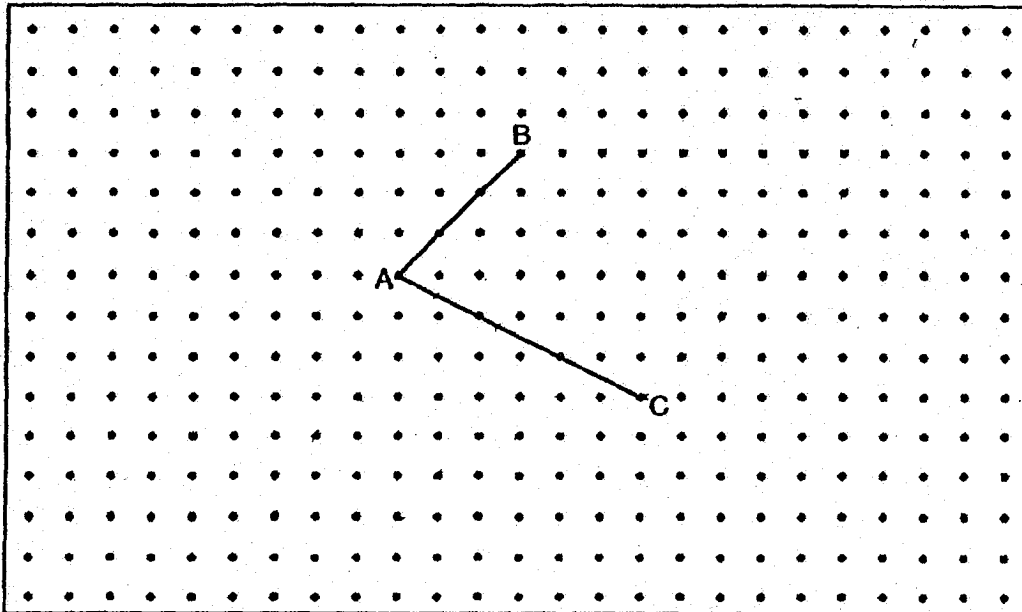

(a) X is one of the dots inside the box. Draw two lines AX and CX to complete a right-angled triangle ACX with $AC = AX$.

(b) Y ^{is} in one of the dots inside the box. Draw two lines BY and CY to complete a trapezium ABYC where AB is parallel to CY and the length of CY is twice the length of AB.



For questions 6 to 17, show your working clearly and write your answers in the spaces provided. The number of marks available is shown in the brackets [] at the end of each question or part-question.

Do not write in this space

(45 marks)

- 6 In a Sports Meet, the ratio of the number of runners in the Blue Team to the Red Team is 3 : 5. The ratio of the number of runners in the Yellow Team to the Blue Team is 3 : 4. There are 66 more runners in the Red Team than the Yellow Team. How many runners are there altogether?

Ans: _____ [3]

- 7 Isaac had 1.2 m of wire. He used all of it to form two equilateral triangles shown below.

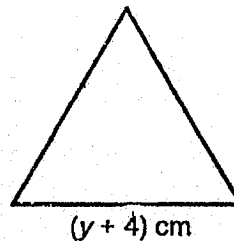
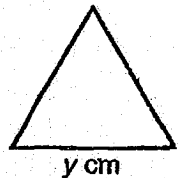

- (a) Find the total perimeter of both triangles in terms of y in the simplest form.
- (b) Find the value of y .

Ans: (a) _____ [1]

(b) _____ [2]

- 8 For every piano that Siti sells, she earns a sum of money as shown below.

Do not write
in this space

10% of the first \$500 of the selling price
and
8% of the remaining selling price

Siti sold a piano and earned \$650. What was the selling price of the piano?

Ans: _____ [3]

- 9 At first, Kendrick had a total of 117 pencils and erasers altogether. He gave away 25 pencils and bought more erasers to increase the number of his erasers by 60%. In the end, Kendrick had a total of 137 pencils and erasers altogether. How many pencils did Kendrick have at first?

Ans: _____ [3]

- 10 Joyce and Val ran in a race. Joyce ran at a speed of 200 m/min. When Val was at the halfway point of the race, Joyce was 2.5 km ahead of Val. Both of them did not change their speed throughout the race. Joyce completed the race at 11.50 a.m. What time did Val complete the race?

Do not write
in this space

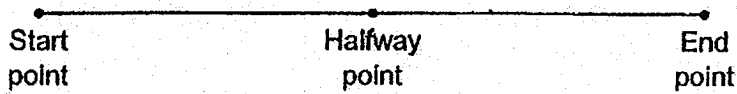

Ans: _____ [3]

11

The pie chart below represents the number of marbles of four different colours in a box. There were 135 more green marbles than red marbles.

Do not write
in this space

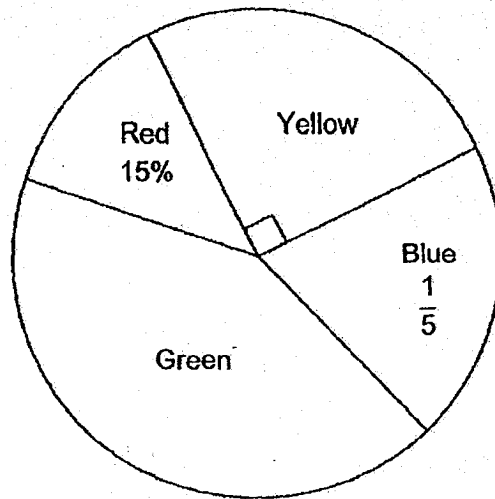

- (a) What percentage of the marbles in the box were green in colour?
- (b) All the marbles in the box were placed in 48 bags. Each bag contained either 8 or 14 marbles. How many of the bags contained 14 marbles?

Ans: (a) _____ [1]

(b) _____ [3]

- 12 In the figure, $ABCG$ is a trapezium and $BCEF$ is a rhombus. Lines BED and BFG are straight lines. Given that $AB \parallel GC$, $EC = ED$, $\angle BFE = 76^\circ$, $\angle GCE = 17^\circ$ and $\angle AGB = 55^\circ$,

- (a) find $\angle p$.
 (b) find $\angle q$.

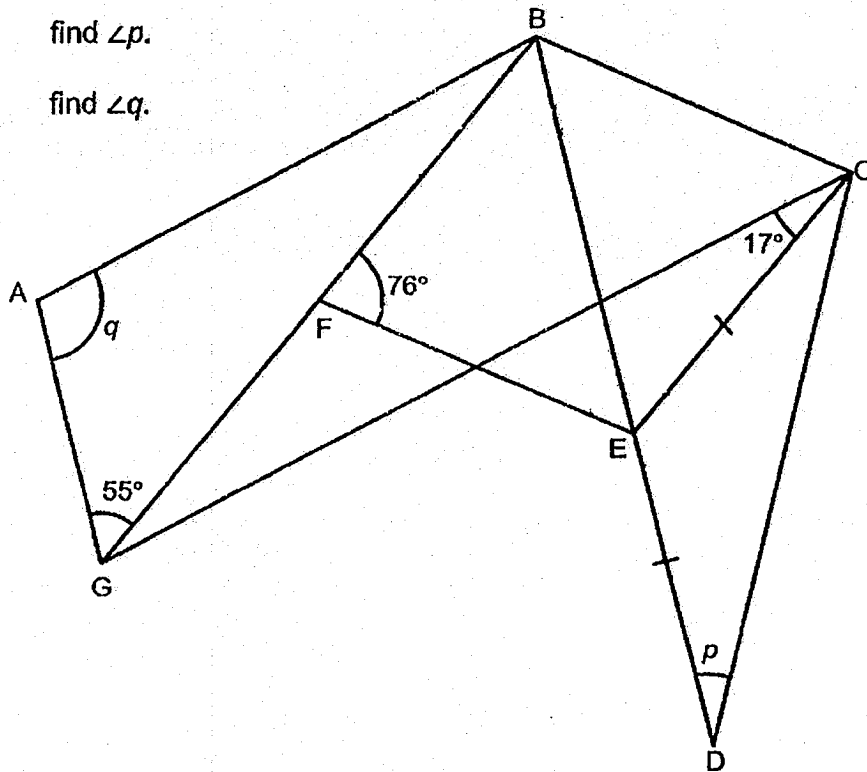

Do not write
in this space

Ans: (a) _____ [2]

(b) _____ [2]

13 Tina had some 20¢, 50¢ and \$1 coins with a total value of \$300.60. 40% of the coins were 20¢ coins and $\frac{1}{8}$ of the remaining coins were \$1 coins.

Do not write
in this space

- (a) What is the ratio of the number of 20¢ coins to the number of 50¢ coins to the number of \$1 coins? Express your answer in the simplest form.
- (b) How many coins did Tina have altogether?

Ans: (a) _____ [2]

(b) _____ [3]

14

Dom had a square piece of paper with an area of 64 cm^2 . He cut out one quarter circle and three identical semicircles from it as shown below. The quarter circle had the same radius as each semicircle.

Do not write
in this space

(a) What is the radius of the quarter circle?

(b) What is the perimeter of the remaining piece of paper?

(Take $\pi = 3.14$)

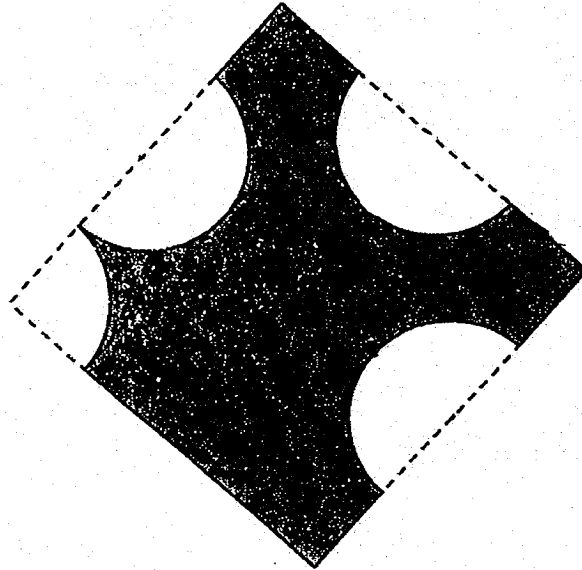

Ans: (a) _____ [2]

(b) _____ [3]



15

John uses triangles and circles to form figures that follow a pattern as shown below.

Do not write in this space



Figure 1

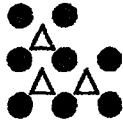

Figure 2

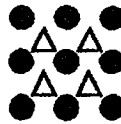

Figure 3

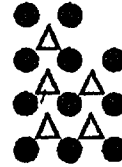

Figure 4

- (a) The table shows the number of triangles and circles for the first four figures. Complete the table for Figure 5.

Figure Number	1	2	3	4	5
Number of triangles	2	3	4	5	
Number of circles	6	8	9	11	
Total number of triangles and circles	8	11	13	16	

[1]

- (b) A figure in the pattern has a total of 51 triangles and circles. What is the Figure Number?
- (c) How many circles did John use for Figure 115?

Ans: (b) Figure _____ [2]

(c) _____ [2]



- 16 The figure below shows an empty wading pool with some steps at one side of the pool. Each step measures 0.2 m in height and 0.4 m in length. Mr Hank wants to fill the pool with water using a hose that allows water to flow at a rate of 1.395 m^3 per hour. How long will it take Mr Hank to fill the pool with water to a depth of 0.7 m measured from the deepest end of the pool?

Do not write in this space

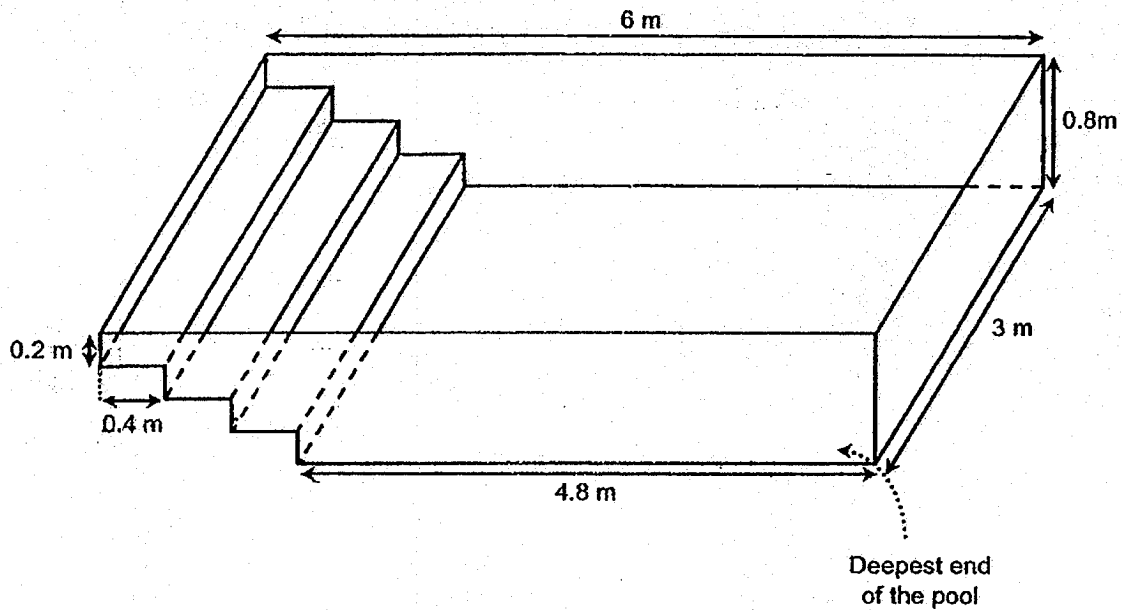

Ans: _____ [4]

- 17 Two square tiles of equal sides are shown below. Some parts of the tiles are painted in the shape of identical quarter circles ().

Do not write
in this space



A floor is laid with the tiles that follow a pattern as shown below. The floor measures 5.2 m in length and 3.6 m in breadth and is completely covered with the tiles.

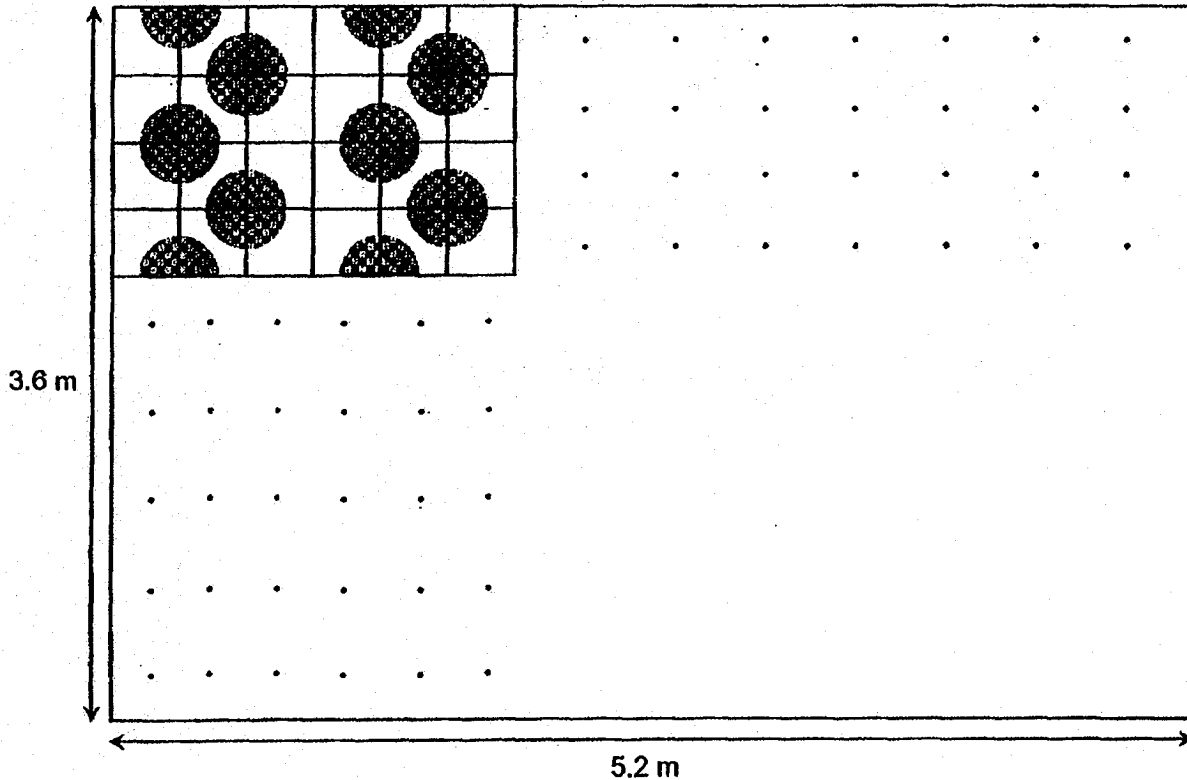

Find the area of the floor that is covered by the painted parts of the tiles.

(Take $\pi = \frac{22}{7}$)

(You may use the additional working space on the next page if necessary)

Ans: _____ [4]

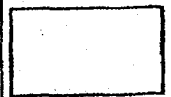

(Additional working space for Question 17)

Do not write
in this space

Setters:

Mrs Elaine Chua, Mrs Irene Tan, Mr Jenfry Tseng, Mrs Ling Lee Ching and Mr Yip Yew Fei

SCHOOL : HENRY PARK PRIMARY SCHOOL
 LEVEL : PRIMARY 6
 SUBJECT : MATH
 TERM : 2019 PRELIM

PAPER 1 BOOKLET A

Q 1	Q2	Q3	Q4	Q5	Q6	Q7	Q8	Q9	Q10
1	2	4	3	4	1	1	4	3	1

Q 11	Q12	Q13	Q14	Q15
3	2	4	3	3

PAPER 1 BOOKLET B

Q16)	110.49
Q17)	5.08
Q18)	$63 + \frac{28-18}{5} = 63 + \frac{10}{5}$ $= 63 + 2 = 65$
Q19)	37.49
Q20)	$70 \div 5 = 14$
Q21)	1 and 7
Q22)	a)EB and DC b)FA and AB
Q23)	a)13h b)3.40 p.m.
Q24)	$155^\circ - 69^\circ = 86^\circ$
Q25)	$\frac{1}{2} \times 6cm \times 45cm = 270cm^2$
Q26)	$\frac{5}{8}T = 4 + 12 + 15 + 9 = 40$ $\frac{3}{8}T = 40 \div 5 \times 3 = 24tickets$
Q27)	$\frac{2}{3}T = 2400ml$ $T = 2400ml \div 2 \times 3 = 3600ml \rightarrow 3600cm^3$

	$\frac{3600\text{cm}^2}{120\text{cm}^2} = 30\text{cm}$
Q28)	85°
Q29)	<p>First hour → \$36 - \$12 = \$24</p> <p>\$24 ÷ \$4 = 6</p> <p>$6 \times \frac{1}{2} = 3h$</p> <p>$3h + 1h = 4h$</p> <p>7.30 + 4 = 11.30</p>
Q30)	126cm ²

PAPER 2

Q1)	<p>a)22</p> <p>b)0.4m</p>
Q2)	<p>$300 \times 2 = 600$</p> <p>$600 - 399 = 201$</p>
Q3)	<p>$180^\circ - 47^\circ = 133^\circ$</p> <p>$180^\circ - 47^\circ - 47^\circ = 86^\circ$</p> <p>$180^\circ - 86^\circ - 36^\circ = 58^\circ$</p>
Q4)	<p>$90 - 22 = 68$</p> <p>$\frac{180-68}{2} = 56$</p>
Q5)	

Q6)	$20u - 9u = 11u$ $11u = 66$ $1u = 66 \div 11 = 6$ $9u + 12u + 20u = 41u$ $41u = 6 \times 41 = 246$
Q7)	a) $(3y + 3y + 12)\text{cm}$ $= (6y + 12)\text{cm}$ b) $(6y + 12)\text{cm} = 120\text{cm}$ $6y \text{ cm} + 12\text{cm} = 120\text{cm}$ $(6y)\text{cm} = 120\text{cm} - 12\text{cm} = 108\text{cm}$ $1y = 108\text{cm} \div 6 = 18\text{cm}$
Q8)	$650 - 50 = 600$ $600 \div 8\% = 7500$ $7500 + 500 = 8000$
Q9)	$u + p = 117 \rightarrow E1$ $u - 25 + 1\frac{3}{5}p = 137 \rightarrow E2$ $u = 117 - p$ $u = 137 - 1\frac{3}{5}p + 25$ $117 - p = 137 - 1\frac{3}{5}p + 25$ $\frac{3}{5}p = \frac{45 \times 5}{3} = 75$ $u = 117 - 75 = 42\text{pencils}$
Q10)	$2500 \times 2 = 5000$ $5000 \div 200 = 25\text{min}$ 25min after 11.50 a.m. is 12.15 p.m.
Q11)	a) $100\% - 25\% - 15\% - 20\% = 40\%$ b) $15\% + 135 \rightarrow 40\%$ $25\% \rightarrow 135$ $1\% \rightarrow 135 \div 25 = 5.4$ $81 + 216 + 135 + 108 = 540$ <u>Assume all as 8 marbles</u> $8 \times 48 = 384$ $540 - 384 = 156$ $156 \div 6 = 26 \text{ bags}$
Q12)	a) $(180^\circ - 76^\circ) \div 2 = 52^\circ$ $180^\circ - 52^\circ = 128^\circ$ $(180^\circ - 128^\circ) \div 2 = 26^\circ$ b) $180^\circ - 59^\circ = 121^\circ$

	$121^\circ - 52^\circ - 52^\circ = 17^\circ$ $180^\circ - 17^\circ - 55^\circ = 108^\circ$
Q13)	a) $16 : 21 : 3$ b) $3.2u + 10.5u + 3u = 16.7u$ $16.7u = \$300.60$ $1u = \$300.60 \div \$16.7u = 18$ $16u + 21u + 3u = 40u$ $40u = 40 \times 18 = 720 \text{ coins}$
Q14)	a) $\sqrt{64\text{cm}^2} = 8\text{cm}$ $8\text{cm} \div 4 = 2\text{cm}$ b) $2\text{cm} + 2\text{cm} + 2\text{cm} + 2\text{cm} + 2\text{cm} + 2\text{cm} + 4\text{cm} = 16\text{cm}$ Arc of 1 quarter circle = $\frac{1}{4} \times \pi \times d = \frac{1}{4} \times 3.14 \times 4\text{cm} = 3.14\text{cm}$ $3.14\text{cm} \times 7 = 21.98\text{cm}$ $21.98\text{cm} + 16\text{cm} = 37.98\text{cm}$
Q15)	a) 6 , 12 , 8 b) 18 c) $3 \times 58 + 13 = 177$
Q16)	$6\text{m} \times 3\text{m} \times 0.7\text{m} = 12.6\text{m}^3$ $0.4\text{m} \times 0.2\text{m} \times 3\text{m} = 0.24\text{m}^3$ $0.24\text{m}^3 \times 6 = 1.44\text{m}^3$ $12.6\text{m}^3 - 1.44\text{m}^3 = 11.16\text{m}^3$ $11.16\text{m}^3 \div 1.395\text{m}^3 = 8\text{h}$
Q17)	$520 \div 20 = 26$ $26 \div 3 = 8R2$ $8.75 \times \frac{22}{7} \times 14 \times 14 = 5390$ $360 \div 20 = 18$ $18 \times 5390 = 97020\text{cm}^2$



Maha Bodhi School
2019 Preliminary Examination
Primary 6
Mathematics
Paper 1
(Booklet A)

Name : _____ ()

Class : Primary 6 _____

Date : 27 August 2019

Total duration for Booklets A and B: 1 hour

INSTRUCTIONS TO CANDIDATES:

1. Write your Index No. in the boxes at the top right hand corner.
2. Do not turn over this page until you are told to do so.
3. Follow all instructions carefully.
4. Answer all questions.
5. Shade your answers in the Optical Answer Sheet (OAS) provided.
6. The use of calculators is **NOT** allowed.

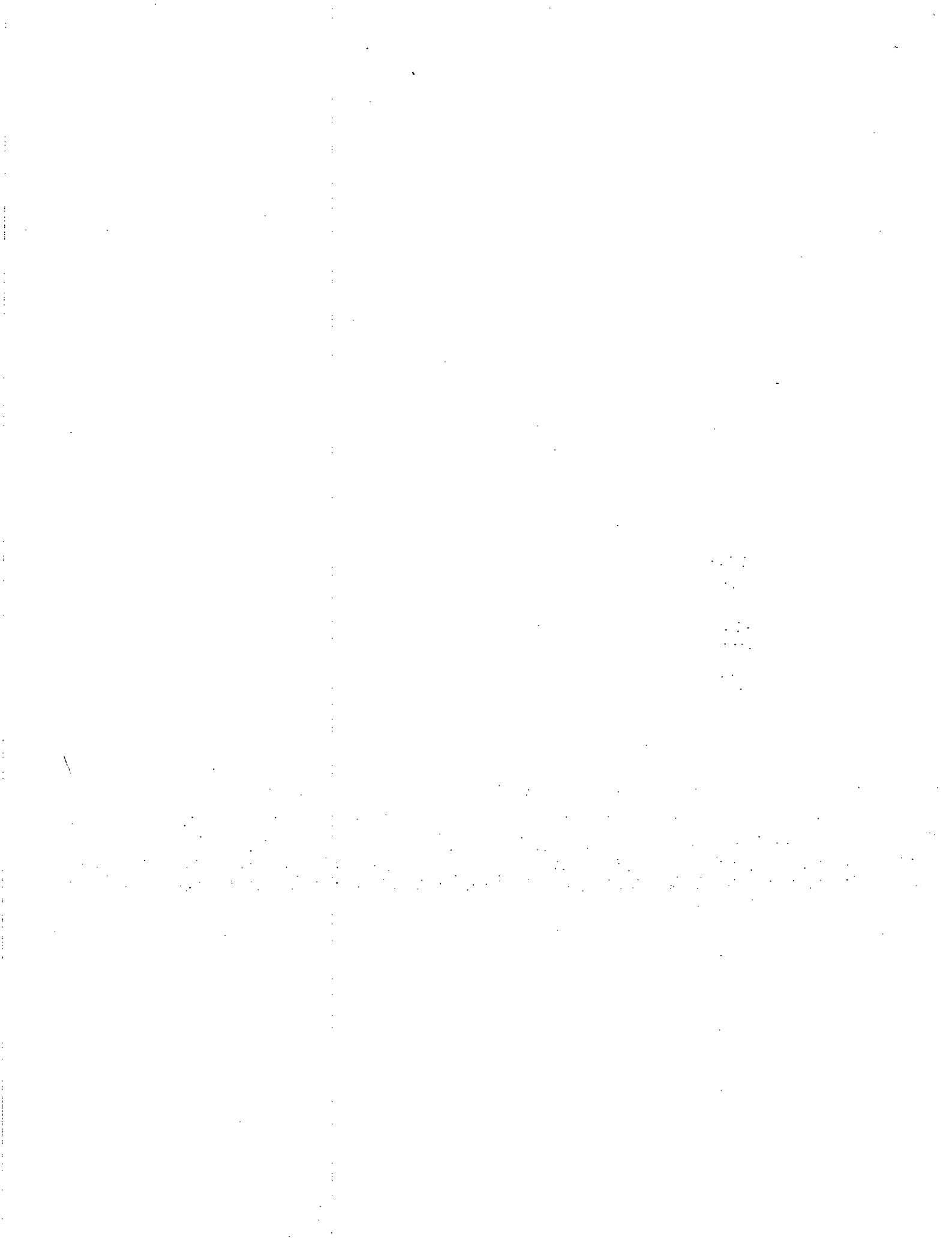

Questions 1 to 10 carry 1 mark each. Questions 11 to 15 carry 2 marks each.
For each question, four options are given. One of them is the correct answer.
Make your choice (1, 2, 3 or 4) and shade your answer on the Optical Answer Sheet.
(20 marks)

1. In which one of the following numbers does the digit 6 have the smallest value?

- (1) 76 859
- (2) 68 597
- (3) 597 684
- (4) 498 765

2. A tailor had 5 m of cloth. He used $\frac{3}{8}$ of it. How much cloth had he left?

- (1) $4\frac{5}{8}$ m
- (2) $4\frac{3}{8}$ m
- (3) $3\frac{1}{8}$ m
- (4) $1\frac{7}{8}$ m

3. The length of a double-decker bus in Singapore is about _____.

- (1) 11 cm
- (2) 11 m
- (3) 110 cm
- (4) 110 m

4. Study the straight lines on the protractor below.
Which two angles are equal?

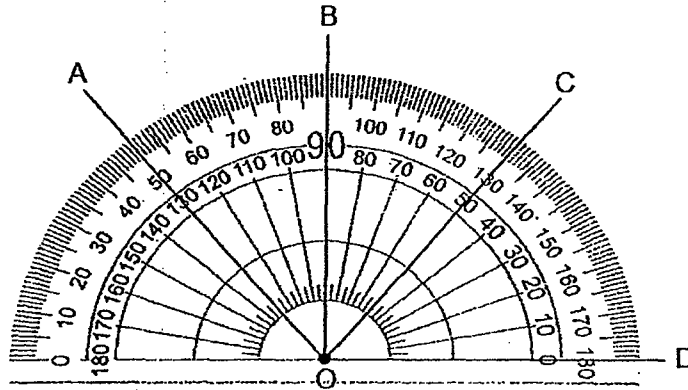

- (1) $\angle AOC = \angle BOD$
(2) $\angle AOB = \angle BOC$
(3) $\angle BOC = \angle COD$
(4) $\angle AOB = \angle COD$
5. Find the average of the following numbers.

10	18	26	30
----	----	----	----

- (1) 18
(2) 21
(3) 26
(4) 28
6. A machine packs 25 apples into a box in 1 minute. At the same rate, how many apples can be packed in 1 hour 40 minutes?
- (1) 1000
(2) 1500
(3) 2500
(4) 3500

7. A string was used to form Square X. The string was then used to form Figure Y with three straight sides and one curved side.

Square X has the same perimeter as Figure Y with $AB = BC = CD = 10$ cm.

Find the length of the curved side AD.

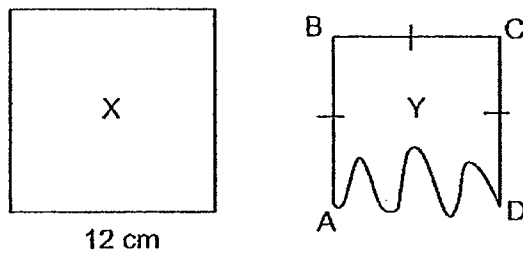

- (1) 10 cm
 (2) 12 cm
 (3) 18 cm
 (4) 30 cm
8. In the diagram below, O is the centre of the circle and RQ is its diameter. RPQ is a triangle and P, Q and R are points on the circumference of the circle. $\angle QOP = 92^\circ$, find $\angle ORP$.

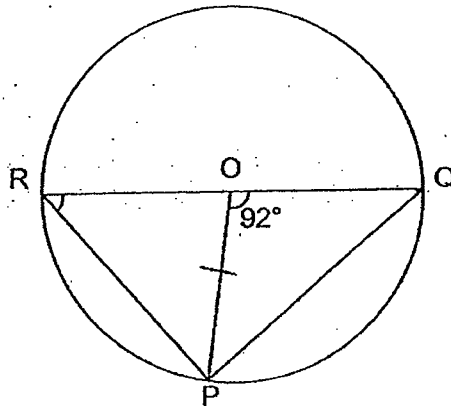

- (1) 41°
 (2) 44°
 (3) 46°
 (4) 88°

9. The ticketing office at a cinema opens at 10 a.m.
The line graph below shows the number of unsold tickets at the ticketing office after three hours.

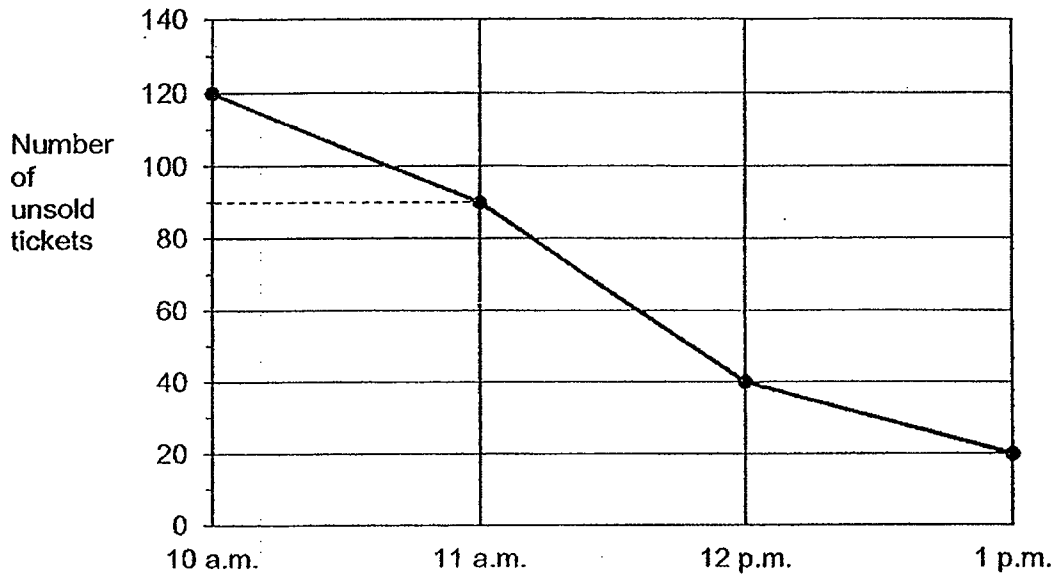

How many tickets were sold in the first hour?

- (1) 120
(2) 90
(3) 30
(4) 20
10. At 11.00 a.m., a car left Town X for Town Y travelling at a speed of 80 km/h. At the same time, another car left Town Y for Town X travelling at a speed of 100 km/h. They did not change their speeds throughout. The distance between the two towns was 540 km. At what time did the cars pass each other?
- (1) 1 p.m.
(2) 2 p.m.
(3) 3 p.m.
(4) 4 p.m.

11. What is the mass of Box X?

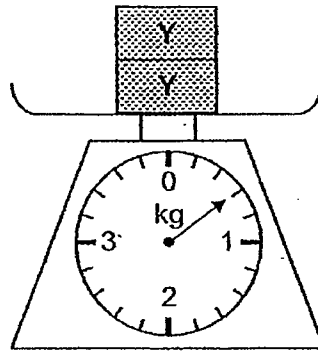
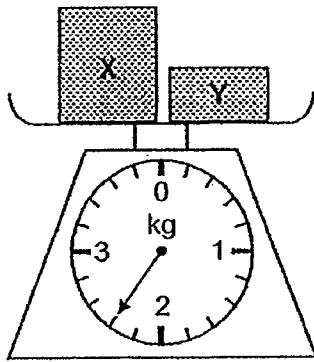

- (1) 0.3 kg
(2) 1.8 kg
(3) 1.9 kg
(4) 2.1 kg
12. Plank A is 1.5 m longer than Plank B.
Plank A is 60 cm longer than Plank C. The total length of the three planks is 12.6 m.
Find the length of Plank B.
- (1) 3.4 m
(2) 3.5 m
(3) 4.3 m
(4) 4.9 m
13. 25% of the books in a library are Malay books. 40% of the remainder are Chinese books. The rest are English books. What percentage of the books are English books?
- (1) 30%
(2) 35%
(3) 45%
(4) 55%

14. Which one of the following can be the net of the solid shown below?

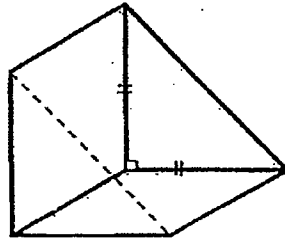

(1)

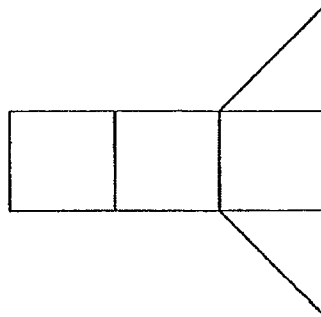

(2)

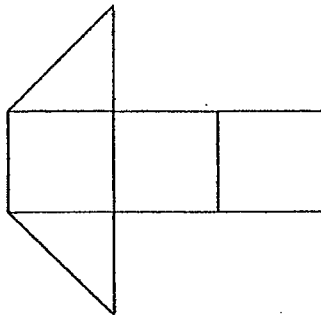

(3)

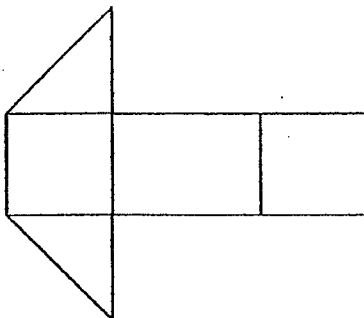

(4)

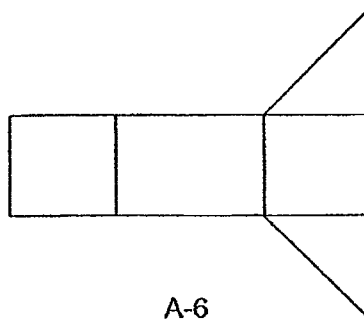

15. In the diagram below, ABCD is a parallelogram and PQRS is a rhombus. $PB = BN$, $\angle APS = 40^\circ$ and $\angle PQR = 86^\circ$. Find $\angle ADC$.

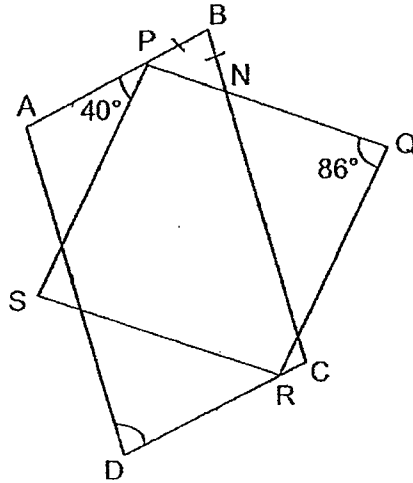

- (1) 72°
- (2) 88°
- (3) 92°
- (4) 94°

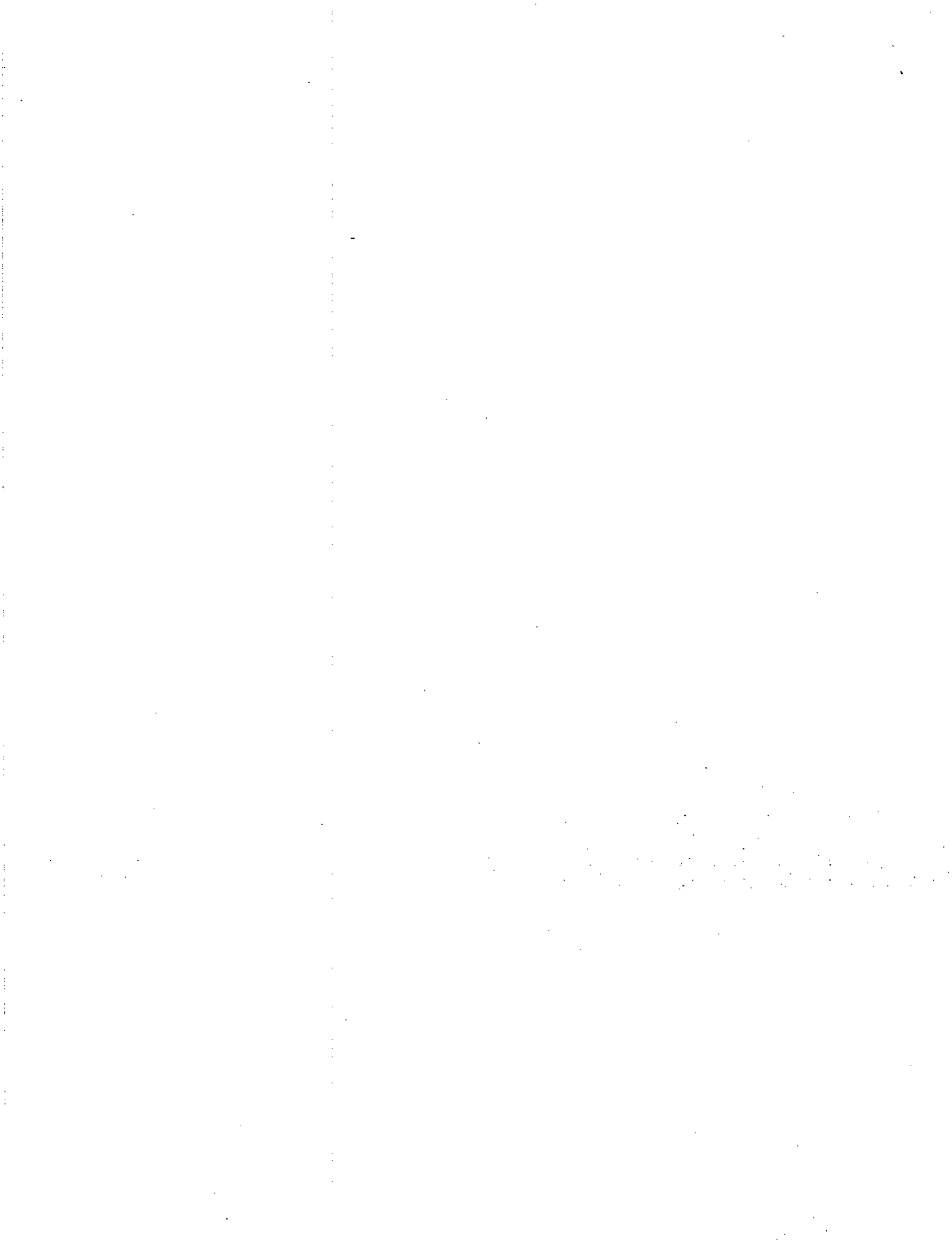



Maha Bodhi School
2019 Preliminary Examination
Primary 6
Mathematics
Paper 1
(Booklet B)

Name : _____ ()

Marks:

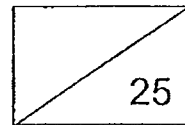

Class : Primary 6 _____

Date : 27 August 2019

Total Duration for Booklets A and B: 1 hour

INSTRUCTIONS TO CANDIDATES:

1. Write your Index No. in the boxes at the top right hand corner.
2. Do not turn over this page until you are told to do so.
3. Follow all instructions carefully.
4. Answer all questions.
5. Write all your answers in this booklet.
6. The use of calculators is **NOT** allowed.

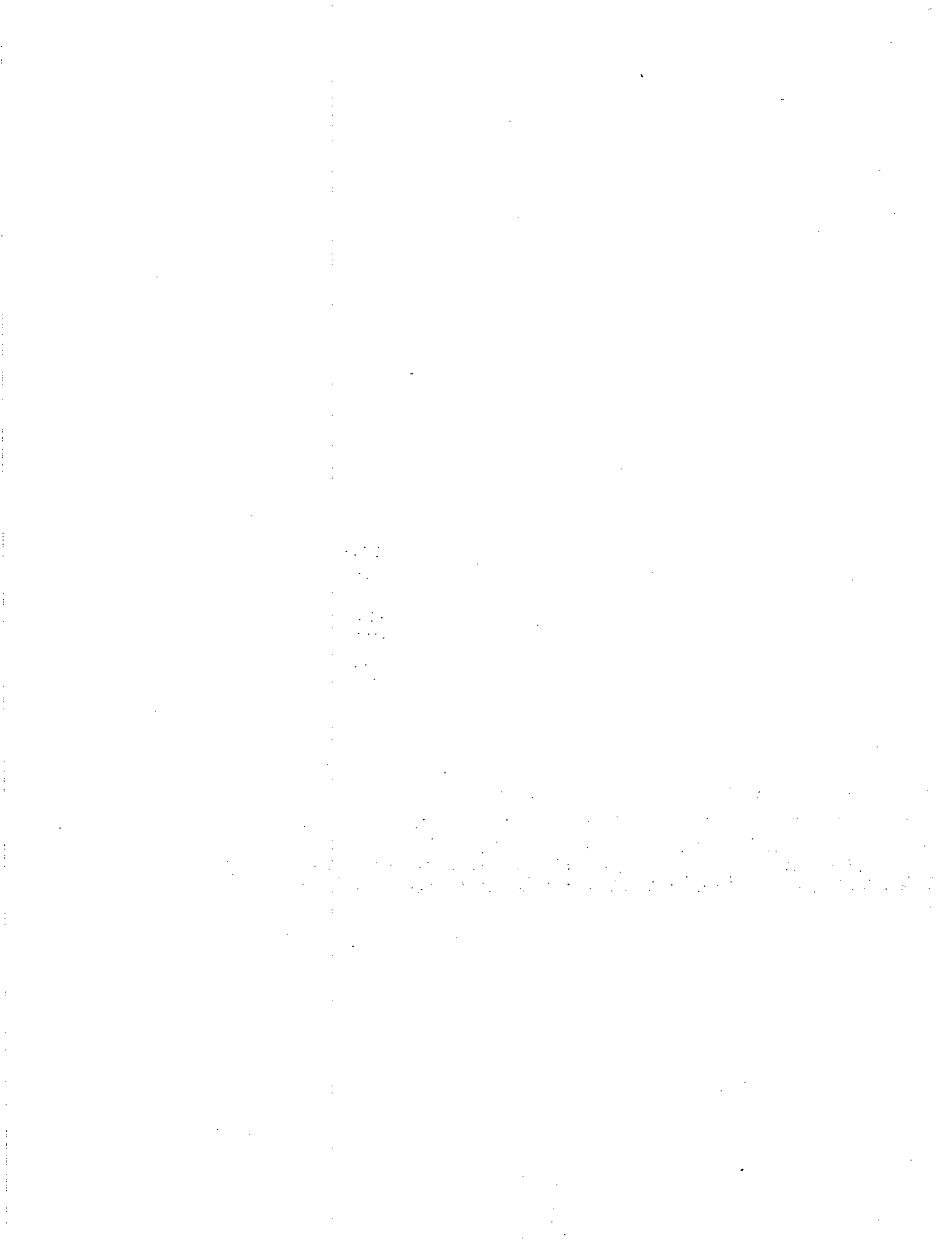

Questions 16 to 20 carry 1 mark each. Write your answers in the spaces provided.
For questions which require units, give your answers in the units stated. (5 marks)

16. Write 17 hundreds in numerals.

Ans: _____

17. The rectangle shown below is made up of 30 identical squares.
What fraction of the rectangle is shaded? Leave your answer in the simplest form.

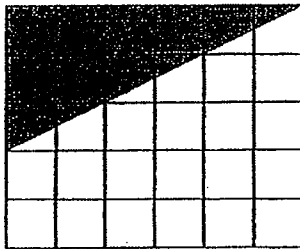

Ans: _____

18. A solid cuboid has a square base of side 5 cm. It has a volume of 300 cm^3 .
What is its height?

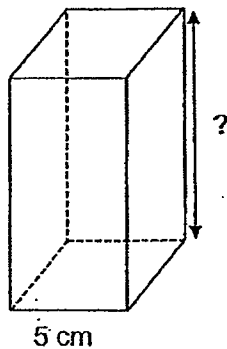

Ans: _____ cm

19. The average mass of five objects is 2.4 kg.
The total mass of four of the objects is 10.8 kg.
What is the mass of the fifth object?

Ans: _____ kg

20. A duck has a mass of $3y$ kg.
A kitten is 3 kg heavier than the duck.
Find the total mass of the two animals in terms of y .

Ans: _____ kg

Questions 21 to 30 carry 2 marks each. Show your working clearly and write your answers in the spaces provided. For questions which require units, give your answers in the units stated. (20 marks)

21. In the number line below, what is the value of X?
Give your answer as a decimal.

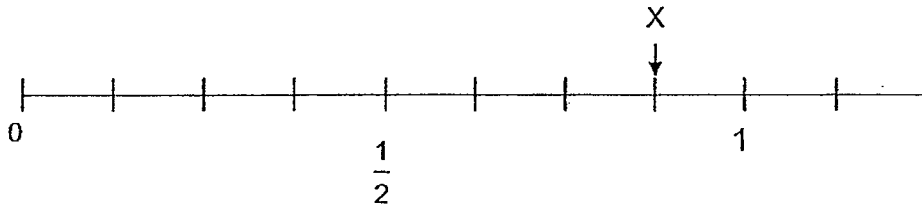

Ans: _____

22. In the figure below, PQRS is a rectangle.
H and K are points on PQ and QR respectively such that PH = 4 cm and KR = 6 cm.
Find the area of the shaded triangle HKR.

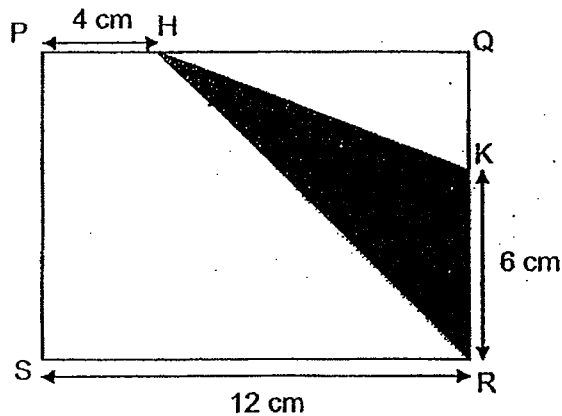

Ans: _____ cm²

23. In the grid below, draw a line parallel to AB and passing through X.

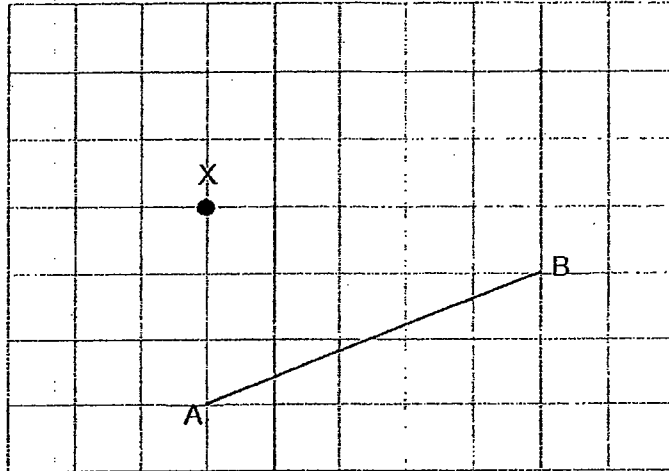

24. Apples are sold at four for \$5 and pears are sold at six for \$8.
Kishan bought the same number of apples and pears.
What is the least amount of money he could have spent?

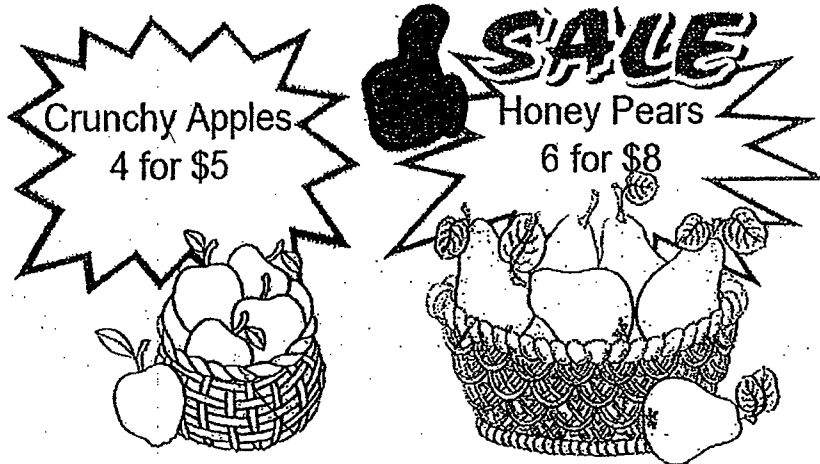

Ans: \$ _____

25. Sulaiman and Susan brought different amounts of money to school.

Sulaiman spent $\frac{1}{2}$ of his money and Susan spent $\frac{1}{4}$ of hers at recess.

Each of the statements below is either true, false or not possible to tell from the information given. For each statement, put a tick (✓) to indicate your answer.

Statement	True	False	Not possible to tell
Sulaiman spent more money than Susan.			
Sulaiman had a larger fraction of his money left than Susan.			

26. Haron and Raj had an equal number of stamps at first. After Haron sold 26 stamps and Raj sold 66 stamps, the ratio of the number of stamps Haron had left to the number of stamps Raj had left was 5 : 1. How many stamps did Raj have at first?

Ans: _____ stamps

27. In the diagram below, $WXYZ$ is a parallelogram and ZV is a straight line.

Given that $XY = YZ$ and $\angle WXV = 130^\circ$, find $\angle ZWX$.

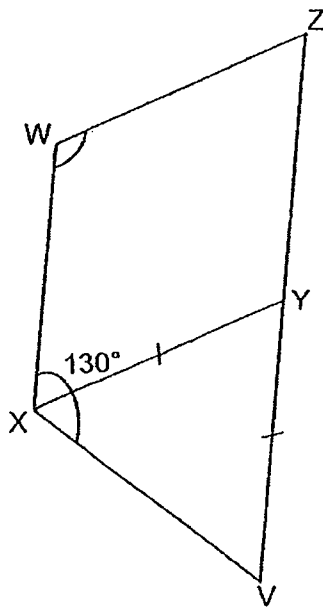

Ans: _____°

28. Pupils in a class were asked to choose a colour for their class T-shirt. Their responses are shown in the pie-chart below. AB is a straight line.

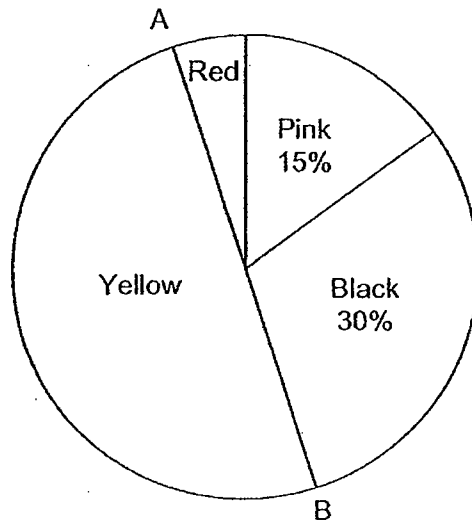

What fraction of the pupils chose red for their class T-shirt?

Ans: _____

29. Mrs Tan has $(2n + 16)$ m of ribbon. She gave away 13 m. Then she cut the remaining ribbon into 3 equal pieces. What is the length of each piece of ribbon?

Ans: _____ m

30. There are some identical cubes in a box as shown below. How many more cubes are needed to fill up the box?

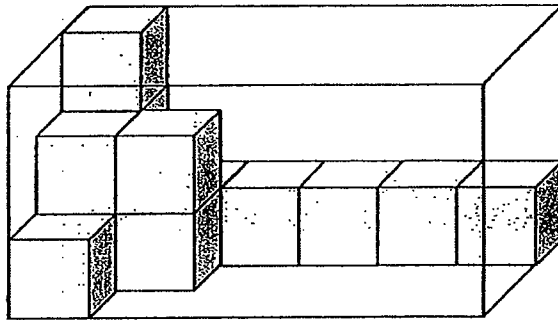

Ans: _____



Maha Bodhi School
2019 Preliminary Examination
Primary 6
Mathematics
Paper 2

Name : _____ ()

Class : Primary 6 _____

Date : 27 August 2019

Duration: 1 h 30 min

INSTRUCTIONS TO CANDIDATES:

1. Write your Index No. in the boxes at the top right hand corner.
2. Do not turn over this page until you are told to do so.
3. Follow all instructions carefully.
4. Answer all questions.
5. Write your answers in this booklet.
6. The use of an approved calculator is expected, where appropriate.

Paper	Booklet	Marks Obtained	Max Marks
1	A		20
	B		25
2	-		55
Total			100

Parent's signature: _____

This booklet consists of 15 printed pages.

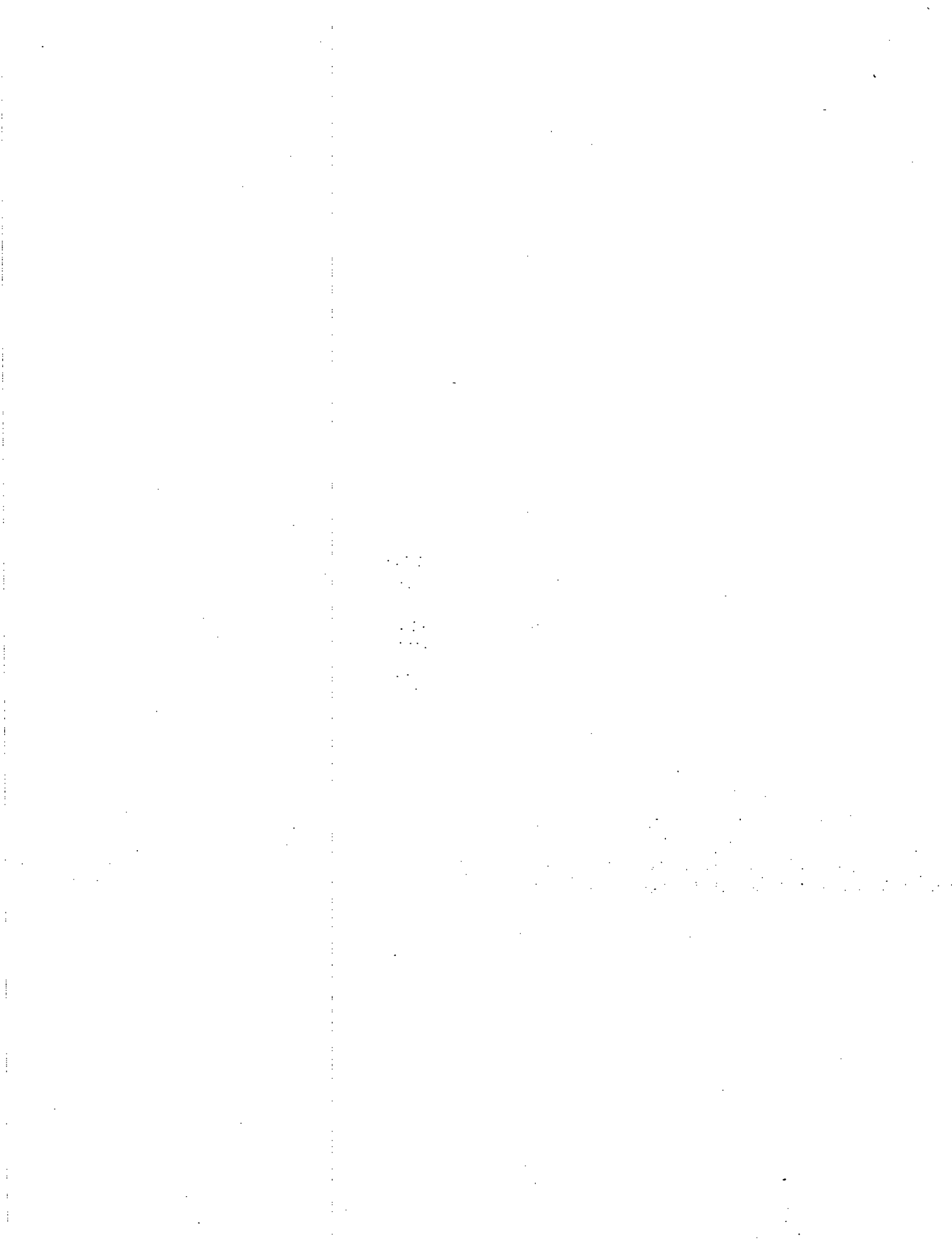

Questions 1 to 5 carry 2 marks each. Show your working clearly and write your answers in the spaces provided. For questions which require units, give your answers in the units stated. (10 marks)

1. A class of 40 pupils was asked to name their favourite food. Each pupil chose one type of food. The bar for the number of pupils who chose Mee Siam as their favourite food has not been drawn.

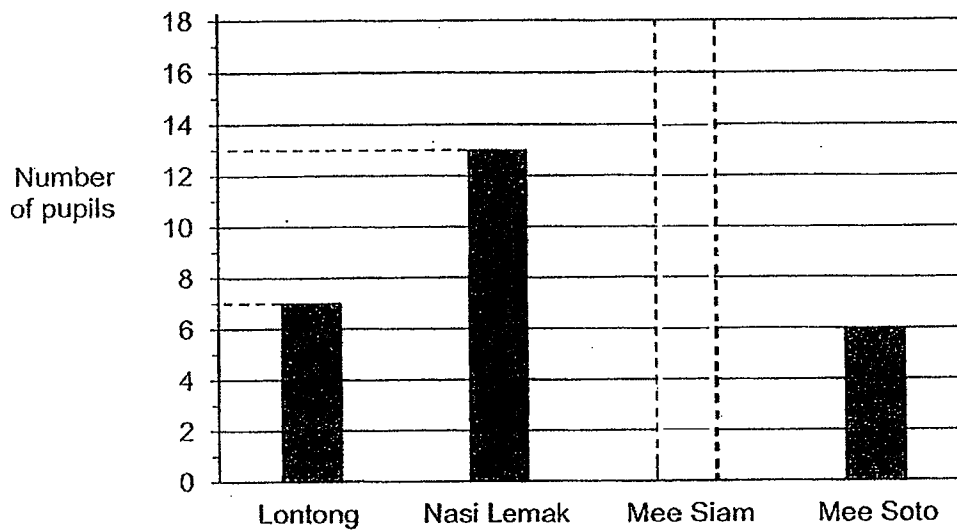

Draw the bar for the number of pupils who chose Mee Siam as their favourite food in the graph above.

2. Each figure below is made up of identical lines. The first 4 figures are shown below. Based on the pattern observed in Figures 1 to 4, how many lines are needed to form Figure 101?



Figure 1



Figure 2



Figure 3



Figure 4

Ans: _____ lines

3. Three classes collected papers for recycling. 6A collected $4x$ kg, which is half of what 6B collected. 6B collected 5 kg more than 6C. How many kg of papers did they collect altogether?

Give your answer in terms of x in the simplest form.

Ans: _____ kg

4. The figure below shows a square of side 14 cm and 4 identical quarter circles.

Find the area of the shaded parts. Take $\pi = \frac{22}{7}$

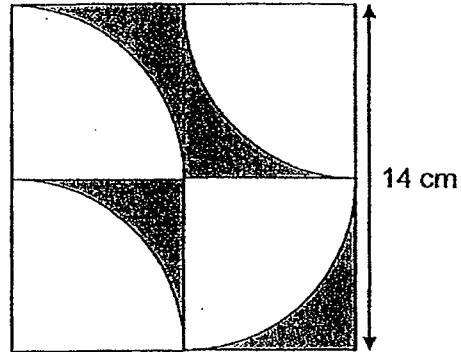

Ans: _____ cm²

5. At a school event, 15 pupils were standing in a straight line at equal distances from each other. The distance between the third and tenth pupil was 12.11 m. What was the distance between the first and last pupil?

Ans: _____ m

For questions 6 to 17, show your working clearly and write your answers in the spaces provided. The number of marks available is shown in brackets [] at the end of each question or part-question. (45 marks)

6. PQRS is a rhombus.
- (a) Using the protractor given, find $\angle QRS$
- (b) then calculate $\angle PQS$

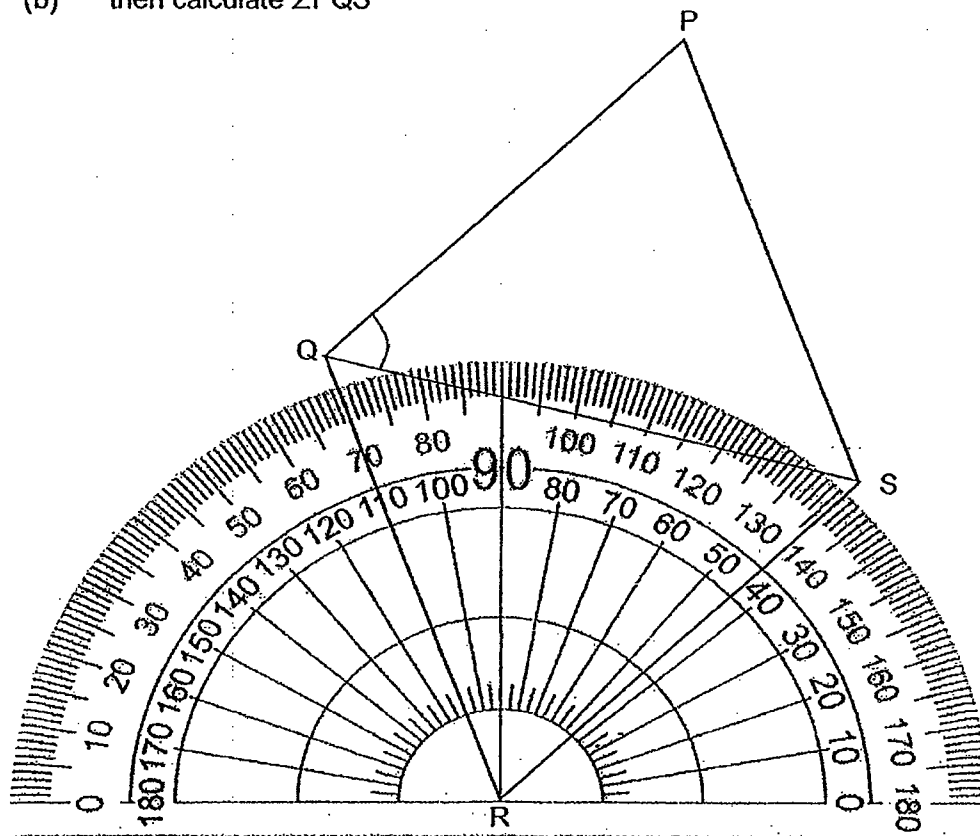

Ans: (a) _____ [1]

(b) _____ [2]

7. Some points are marked on the square grid shown in the diagram below.

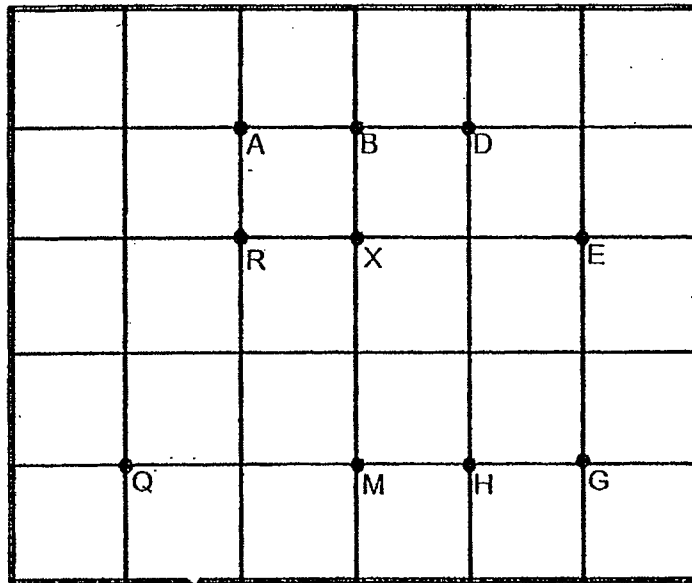

- (a) (i) Point X is west of Point _____ .
(ii) Point X is north-east of Point _____ .
- (b) Sally was standing at Point X and she was facing Point D.
She then turned in an anti-clockwise direction until she was facing Point G.
How many complete right angles did she turn?
- (c) REGQ and REGM are trapeziums with a pair of parallel sides.
Name 1 other such trapezium with RB as one of the parallel sides.

Ans: (a) (i) _____

(ii) _____ [1]

(b) _____ [1]

(c) Trapezium _____ [1]

8. Jasmine and Kaixin started cycling at the same time along a 5.2 km track. Both of them did not change their speeds from start to finish. Jasmine cycled at 400 m/min. When she reached the end of the track, Kaixin was 780 m behind her. What was Kaixin's cycling speed in m/min?

Ans: _____ [3]

9. In the figures below, Tank A and Tank B are partially filled with water. All the water from both Tank A and Tank B is poured into Tank C. What is the height of water in Tank C?

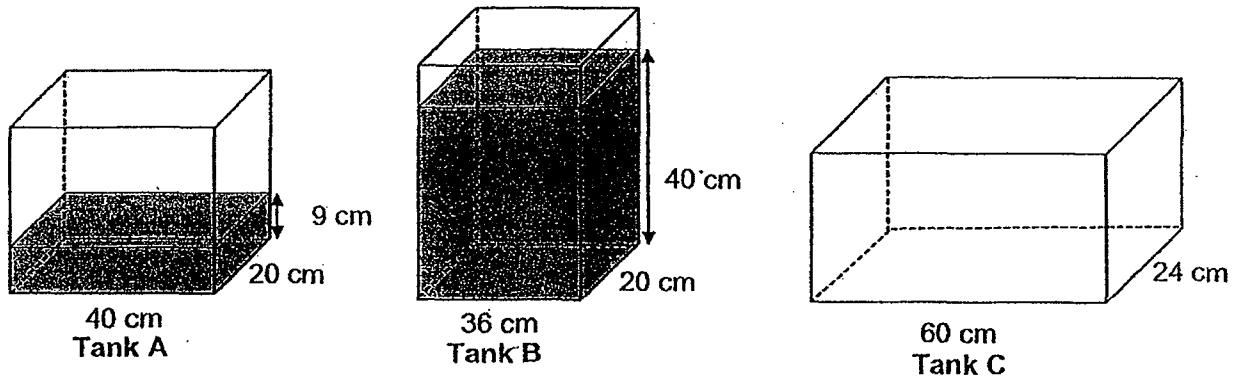

Ans: _____ [4]

14

10. Two groups of pupils sold handicrafts for charity. Card holders are sold at \$15 each and photo frames are sold at \$8 each. The table below shows the items sold by Group A.

Item	Number of items sold	Cost per item
Card holders	9	\$15
Photo frames	12	\$8

- (a) What was the total amount of money collected by Group A?
- (b) Group B sold as many handicrafts as Group A but collected an additional amount that is more than \$50.
What could possibly be the number of card holders and photo frames sold by Group B?

Ans: (a) _____ [2]

(b) Card holders: _____

Photo frames: _____ [2]

11. Three boxes, A, B and C, contain some marbles. Box C contains 272 marbles.

Box A contains $\frac{3}{4}$ of the total number of marbles in Boxes B and C. The ratio of the number of marbles in Box B to the number of marbles in Box C is 1 : 2.

How many marbles are there altogether in Boxes A and B?

Ans: _____ [3]

12. Last year, the ratio of the number of men to the number of women who signed up for a marathon was 5 : 4. This year, the number of men increased by 30% and the number of women decreased by 50%. A total of 4675 men and women signed up for the marathon this year. What is the difference between the total number of people who signed up for the marathon in the two years?

Ans: _____ [3]

13. Ali, Banu, Caixuan and Dave shared a bag of beads.

Ali had $\frac{1}{2}$ as many beads as Banu.

The total number of beads Ali and Banu had was $\frac{3}{5}$ the number of beads Caixuan had.

Dave had $\frac{2}{5}$ the total number of beads the four children had.

Dave had 52 beads more than Ali.

- (a) What fraction of the beads did Banu have?
- (b) How many beads did the children have altogether?

Ans: (a) _____ [2]

(b) _____ [2]

14. A unit shape in the form of a quadrilateral is drawn in the dot paper below.
It has an area of $2x$ units².

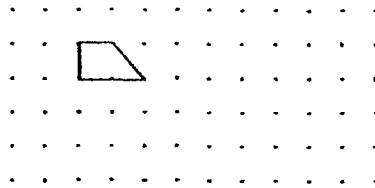

A quadrilateral with 2 lines of symmetry is formed when 2 such unit shapes are joined together as shown below.

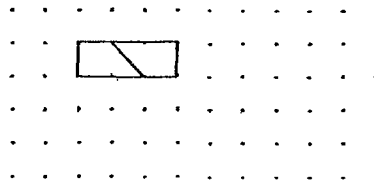

Using the smallest number of unit shapes,

- (a) (i) form a square. [1]
(ii) find the area of the square in terms of x .

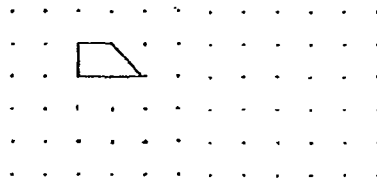

- (b) (i) form a quadrilateral that has only one line of symmetry. [1]
(ii) name the type of quadrilateral formed.

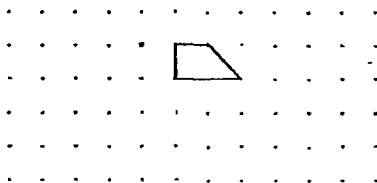

Ans: (a)(ii) _____ [1]

(b)(ii) _____ [1]

15. Sharon receives \$50 from her father each month as pocket money. She spends some money and saves the rest. The line graph below shows the amount of pocket money she saved over a period of 5 months.

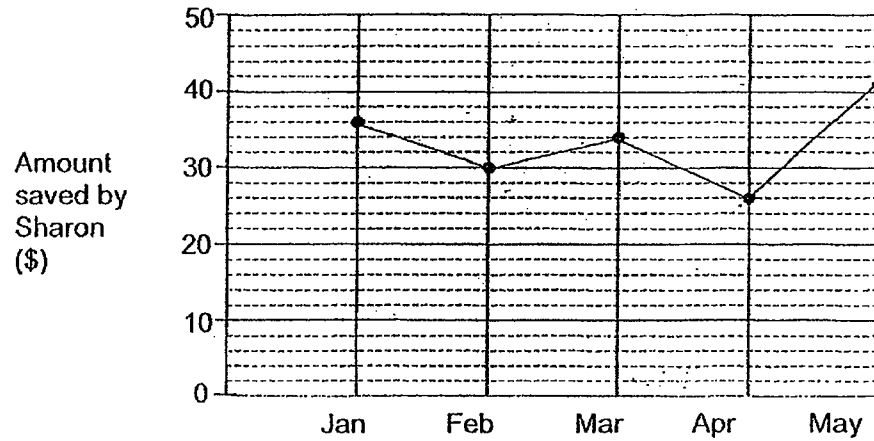

- (a) What is her total savings from January to May?
(b) In which month did she spend the most?
(c) Sharon wants to buy a bicycle which costs \$230. How many more months does she need to save after May so that she can buy the bicycle as soon as possible?

Ans: (a) _____ [1]

(b) _____ [1]

(c) _____ [2]

16. The figure below is formed by 2 quadrants and a rectangle overlapping one another.
The radius of the smaller quadrant is 10 cm.
Find the area of the shaded part of the figure.

Take $\pi = 3.14$

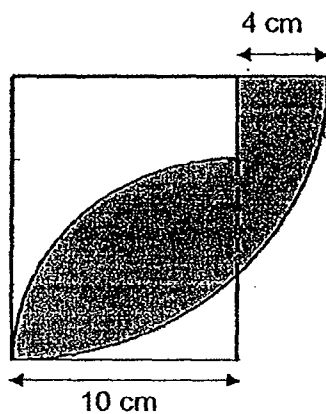

Ans: _____ [5]

17. A man bought $\frac{3}{5}$ as many cartons of mangoes as papayas.

He paid \$540 for the mangoes and papayas.

The total cost of the mangoes was twice that of the papayas.

Each carton of mangoes cost \$28 more than each carton of papayas.

(a) How much did he pay for the mangoes?

(b) How many cartons of papayas did he buy?

Ans: (a) _____ [2]

(b) _____ [3]

Remember to check your work!
~ End of Paper ~

/ 5

SCHOOL : MAHA BODHI PRIMARY SCHOOL
 LEVEL : PRIMARY 6
 SUBJECT : MATH
 TERM : 2019 PRELIM

PAPER 1 BOOKLET A

Q 1	Q2	Q3	Q4	Q5	Q6	Q7	Q8	Q9	Q10
4	3	2	2	2	3	3	3	3	2

Q 11	Q12	Q13	Q14	Q15
4	1	3	4	2

PAPER 1 BOOKLET B

Q16)	1700
Q17)	$6 \times 3 = 18$ $\frac{1}{2} \times 18 = 9$ $\frac{9}{30} = \frac{3}{10}$
Q18)	$5 \times 5 = 25$ $300 \div 25 = 12$
Q19)	$2.4 \times 5 = 12$ $12 - 10.8 = 1.2$
Q20)	$3y + 3y + 3 = (6y + 3)$
Q21)	$\frac{1}{2} \div 4 = \frac{1}{2} \times \frac{1}{4} = \frac{1}{8}$ $\frac{1}{8} = \frac{125}{1000} = 0.125$ $= 0.125 \times 3 = 0.375$ $= 0.5 + 0.375 = 0.875$
Q22)	$12 - 4 = 8$ $\frac{1}{2} \times 8 \times 6 = 24cm^2$

Q23)

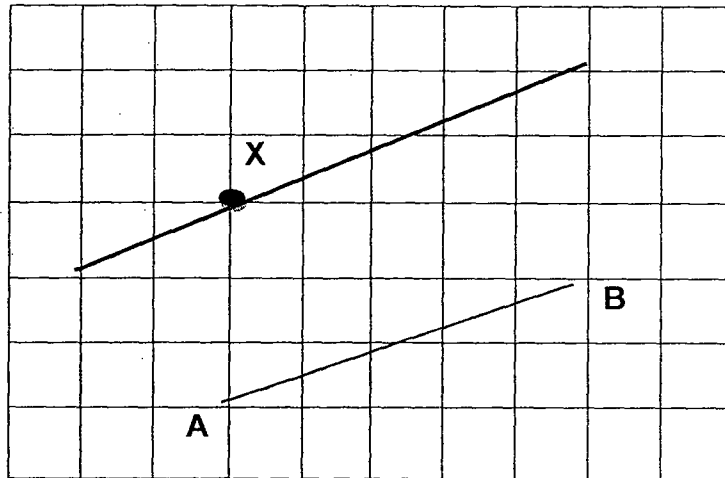

Q24)

Multiple of 4 : 4,8,12 Multiple of 6 : 6,12
 $3 \times 5 = 15$
 $2 \times 8 = 16$
 $15 + 16 = \$31$

Q25)

			√
		√	

Q26)

$5 - 1 = 4$
 $66 - 26 = 40$
 4 units = 40
 1 unit = $40 \div 4 = 10$
 $10 + 66 = 76$ stamps

Q27)

$\angle XVZ = 180^\circ - 130^\circ = 50^\circ$
 $\angle XVZ = \angle YXV = 50^\circ$
 $\angle XYV = 180^\circ - 50^\circ \times 2 = 80^\circ$
 $\angle ZYX = 180^\circ - 80^\circ = 100^\circ$
 $\angle ZYX = \angle ZWX = 100^\circ$

Q28)

$\frac{1}{2} \times 100\% = 50\%$
 $50\% - 15\% - 30\% = 5\%$
 $= \frac{5}{100} = \frac{1}{20}$

Q29)

$\frac{2n+16-13}{3} = \left(\frac{2n+3}{3}\right)m$

Q30)	$6 \times 3 \times 3 = 54$ $54 - 13 = 41$
------	--

PAPER 2

Q1)	$7 + 13 + 6 = 26$ $40 - 26 = 14$										
	<table border="1"> <caption>Data from Bar Chart</caption> <thead> <tr> <th>Food Item</th> <th>Number of Pupils</th> </tr> </thead> <tbody> <tr> <td>Lontong</td> <td>7</td> </tr> <tr> <td>Nasi Lemak</td> <td>13</td> </tr> <tr> <td>Mee Siam</td> <td>14</td> </tr> <tr> <td>Mee Soto</td> <td>6</td> </tr> </tbody> </table>	Food Item	Number of Pupils	Lontong	7	Nasi Lemak	13	Mee Siam	14	Mee Soto	6
Food Item	Number of Pupils										
Lontong	7										
Nasi Lemak	13										
Mee Siam	14										
Mee Soto	6										
Q2)	$101 - 1 = 100$ $100 \times 4 = 400$ $6 + 400 = 406$ lines										
Q3)	$4x \times 2 = 8x$ $8x - 5 + 8x + 4x = (20x - 5) \text{ kg}$										
Q4)	$14 \div 2 = 7$ $\frac{22}{7} \times 7 \times 7 \times \frac{1}{4} = 38.5$ $7 \times 7 = 49$ $49 - 38.5 = 10.5$ $10.5 \times 4 = 42 \text{ cm}^2$										
Q5)	$8 - 1 = 7$ $12.11 \div 7 = 1.73$ $15 - 1 = 14$ $1.73 \times 14 = 24.22 \text{ m}$										
Q6)	a) $\angle QRS = \angle QPS = 66^\circ$ b) $\angle PQS = \angle PSQ$										

	$= \frac{180^\circ - 66^\circ}{2} = 57^\circ$
Q7)	<p>a i)E ii)Q b)3 c)Trapezium RBEM</p>
Q8)	<p>$5200m \div 400m/min = 13min$ $5200m - 780m = 4420m$ $4420m \div 13min = 340m/min$</p>
Q9)	<p>$40 \times 20 \times 9 = 2700$ $36 \times 20 \times 40 = 28800$ $28800 + 7200 = 36000$ $36000 \div 60 \div 24 = 25 \text{ cm}$</p>
Q10)	<p>a) $9 \times 15 = 135$ $12 \times 8 = 96$ $96 + 135 = 231$</p> <p>b) Multiple of 7 : 7,14,21,28,35,42,49,56 $15 - 8 = 7$ $56 \div 7 = 8$ $8 + 9 = 17$ card holders $12 + 9 = 21$ $21 - 17 = 4$ photo frames</p>
Q11)	<p>8 units = 272 1 unit = $272 \div 8 = 34$ 9 units = $34 \times 9 = 306$ 4 units = $34 \times 4 = 136$ $136 + 306 = 442$</p>
Q12)	<p>17 units = 4675 18 units = $\frac{4675}{17} \times 18 = 4950$ $4950 - 4675 = 275$</p>

Q13)

a) A : B

$$1 : 2 \rightarrow 3 \rightarrow \frac{3}{5}$$

$$1 \rightarrow \frac{1}{5}$$

A : B : C

$$1 : 2 : 5 \rightarrow 8 \rightarrow \frac{3}{5}$$

17 : B : C : D

$$1 : 2 : 5 : \frac{8}{3} \times 2$$

$$(1 : 2 : 5 : \frac{16}{3}) \times 3$$

$$3 : 6 : 15 : 16$$

$$\frac{6}{3+6+15+16} = \frac{6}{40}$$

b) A : B

$$1 : 2 \times 3$$

$$3 : 6$$

A : B : C

$$3 : 5 \times 3$$

$$9 : 15$$

Dave : All 4

$$2 : 5 \times 8$$

$$16 : 40$$

13 units = 52

$$40 \text{ units} = \frac{52}{13} \times 40 = 160$$

Q14)

a i)

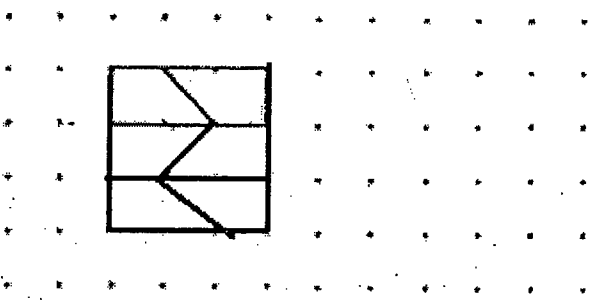

$$\text{ii) } 2x \times 6 = 12x \text{ units}^2$$

b i)

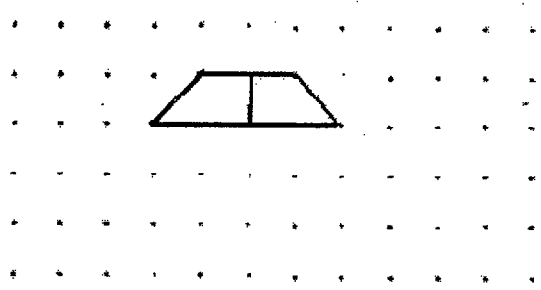

ii) Trapezium

Q15)	<p>a) $36 + 30 + 34 + 26 + 42 = 168$ b) April c) $230 - 168 = \\$62$ 2 more month</p>
Q16)	<p>$10 + 4 = 14$ $14 \times 10 = 140$ $3.14 \times 10 \times 10 \times \frac{1}{4} = 78.5$ $140 - 78.5 = 61.5$ $3.14 \times 14 \times 14 \times \frac{1}{4} = 153.86$ $153.86 - 61.5 = 92.36\text{cm}^2$</p>
Q17)	<p>a) $540 \div 3 = 180$ $180 \times 2 = \\$360$ b) $180 \div 5 = 36$ $360 \div 3 = 120$ $120 - 36 = 84$ $84 \div 28 = 3$ $3 \times 5 = 15$</p>

METHODIST GIRLS' SCHOOL (PRIMARY)

Founded in 1887



PRELIMINARY EXAMINATION 2019 PRIMARY 6 MATHEMATICS

PAPER 1 BOOKLET A

Total Time for Booklets A and B: 1 hour

INSTRUCTIONS TO CANDIDATES

Do not turn over this page until you are told to do so.

Follow all instructions carefully.

Answer all questions.

Shade your answers in the Optical Answer Sheet (OAS) provided.

The use of calculators is **NOT** allowed.

Name: _____ ()

Class: Primary 6. _____

Date: 20 August 2019

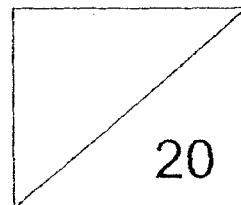

Questions 1 to 10 carry 1 mark each. Questions 11 to 15 carry 2 marks each.
For each question, four options are given. One of them is the correct answer.
Make your choice (1, 2, 3 or 4). Shade the correct oval (1, 2, 3 or 4) on the
Optical Answer Sheet. (20 marks)

1. What does the digit 2 in 7.241 stand for?
- (1) 2 ones
 - (2) 2 tenths
 - (3) 2 hundredths
 - (4) 2 thousandths
2. What is the value of $91\ 000 \div 700$?
- (1) 13
 - (2) 130
 - (3) 1300
 - (4) 13 000
3. Which of the following is the largest in value?
- (1) 0.035
 - (2) 0.305
 - (3) 0.530
 - (4) 0.053

4. The figure below shows a cube.

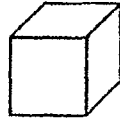

Which one of the following is **not** a net of the cube?

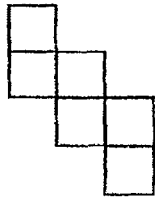

(1)

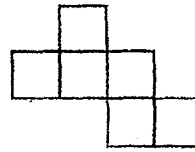

(2)

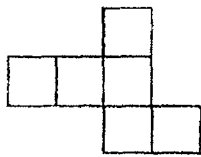

(3)

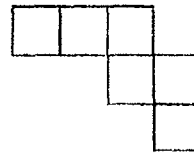

(4)

The graph shows the number of bowls of noodles sold at a stall over 5 days.

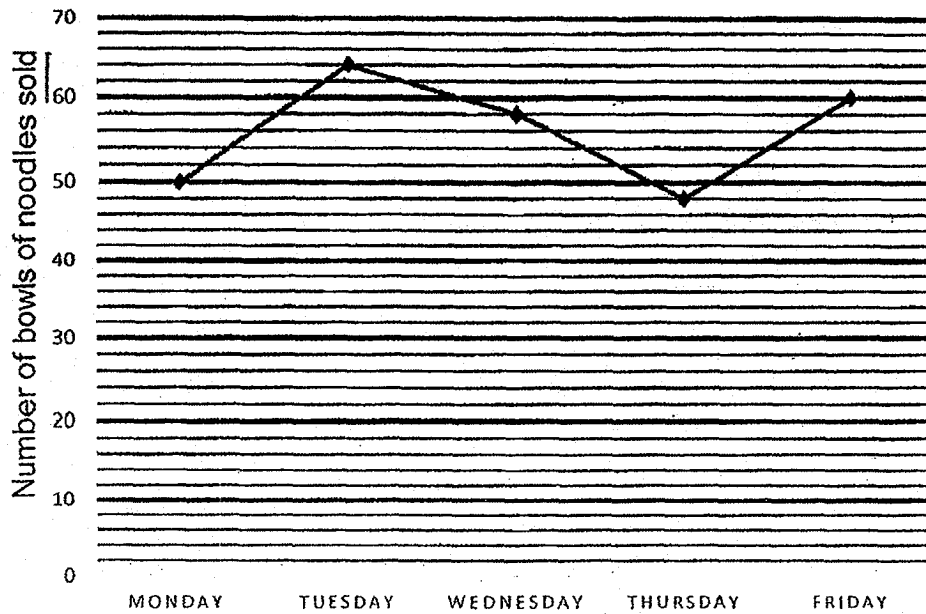

5. How many bowls of noodles were sold from Monday to Wednesday altogether?

- (1) 170
- (2) 171
- (3) 172
- (4) 173

6. Each figure below is made up of nine squares. Four squares in each figure are shaded. Which one of the following figures is symmetric?

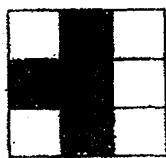

(1)

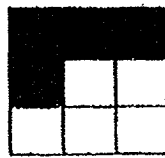

(2)

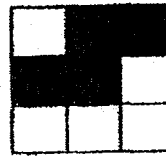

(3)

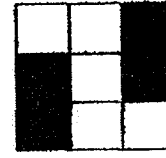

(4)

7. AFD and CFE are straight lines. Find $\angle CFD$.

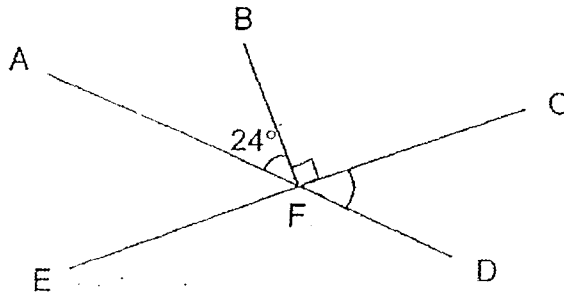

- (1) 24°
- (2) 66°
- (3) 74°
- (4) 76°

8. ABC is an isosceles triangle with $AB = BC$. ACD is a straight line and $\angle ABC = 74^\circ$. Find $\angle BCD$.

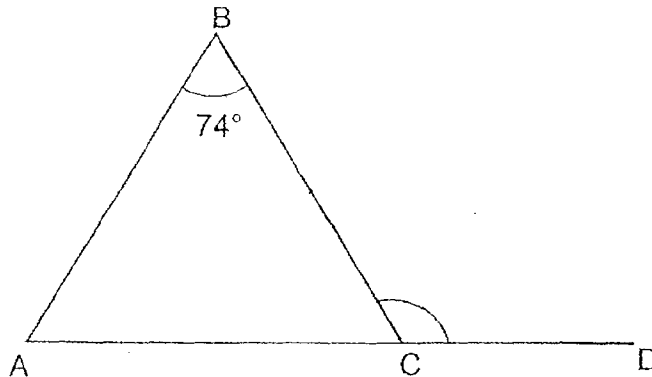

- (1) 53°
- (2) 74°
- (3) 106°
- (4) 127°

9. In the diagram, J, K and L are three points on the ground. Point J is north of point K and $\angle JKL$ is 315° . In what direction is point L from point K?

- (1) North-East
- (2) North-West
- (3) South-East
- (4) South-West

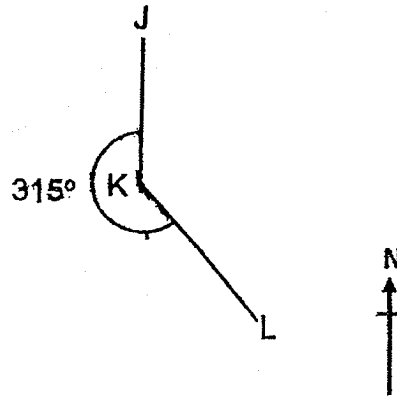

10. A typist can type 70 words in 2 minutes. At this rate, how many words can she type in 30 minutes?

- (1) 140
- (2) 210
- (3) 1050
- (4) 1400

11. A bank gives 2% interest per year. John deposits \$2000 in the bank. How much interest will he receive at the end of one year?

- (1) \$400
- (2) \$40
- (3) \$0.40
- (4) \$4

12. Sammy and Tom shared the total cost of a meal. Sammy paid \$12 more than $\frac{2}{5}$ of the meal. Tom paid \$18. How much did the meal cost?

- (1) \$15
- (2) \$30
- (3) \$50
- (4) \$75

13. Selvi is x years old. Her father is 5 times as old as Selvi and 6 years older than Selvi's mother. How old is Selvi's mother?

- (1) $(5x - 6)$ years old
- (2) $(5x - 30)$ years old
- (3) $(5x + 6)$ years old
- (4) $(5x + 11)$ years old

14. The figure below shows 9 identical cubes which are glued together to form a solid.

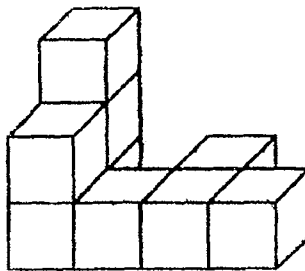

The whole solid, including the base, is then painted red. How many cubes have three of their faces painted red?

- (1) 1
- (2) 2
- (3) 3
- (4) 4

15. Some pupils were surveyed on their favourite ice-cream flavours. The same number of pupils liked vanilla and chocolate. More pupils liked strawberry than cookies and cream. Which one of the following pie charts represents the distribution of pupils?

(1)

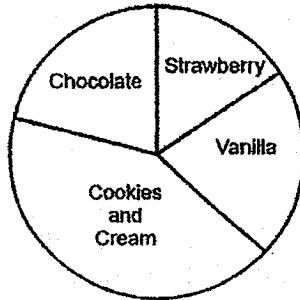

(2)

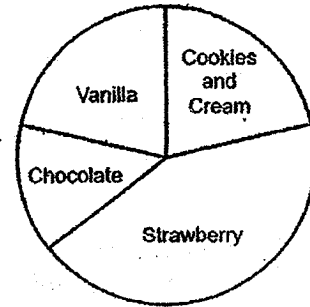

(3)

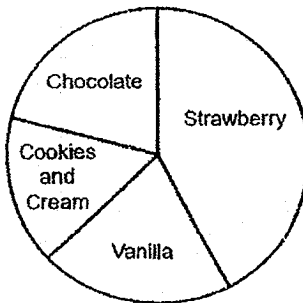

(4)

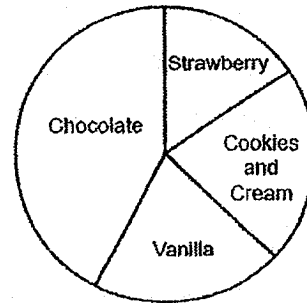

METHODIST GIRLS' SCHOOL (PRIMARY)

Founded in 1887



PRELIMINARY EXAMINATION 2019 PRIMARY 6 MATHEMATICS

PAPER 1 BOOKLET B

Total Time for Booklets A and B: 1 hour

INSTRUCTIONS TO CANDIDATES

Do not turn over this page until you are told to do so.

Follow all instructions carefully.

Answer all questions.

Write your answers in this booklet.

The use of calculators is **NOT** allowed.

Name: _____ ()

Class: Primary 6. _____

Date: 20 August 2019

Paper 1 Booklet A	/ 20
Paper 1 Booklet B	/ 25
Paper 2	/ 55
TOTAL	/ 100

Parent's Signature: _____

This booklet consists of 8 printed pages including this page.

Questions 16 to 20 carry 1 mark each. Write your answers in the spaces provided. For questions which require units, give your answers in the units stated. (5 marks)

Do not write in this space

16. Find the value of 0.14×60

Ans: _____

17. Express 2.35 as a mixed number in the simplest form.

Ans: _____

18. Mary mixed 6 cups of water with 1 cup of syrup to make a drink. What fraction of the drink was made up of syrup?

Ans: _____

19. Edmund cycled for 50 minutes at a speed of 18 km/h. How far did he cycle?

Do not write
in this space

Ans: _____ km

20. Find the value of $9f - \frac{11f}{2}$ when $f = 4$.

Ans: _____

Questions 21 to 30 carry 2 marks each. Show your working clearly and write your answers in the spaces provided. For questions which require units, give your answers in the units stated. (20 marks)

Do not write in this space

21. The figure below shows a pyramid.

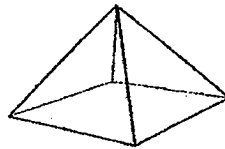

Complete the net of the pyramid in the space provided in the box.

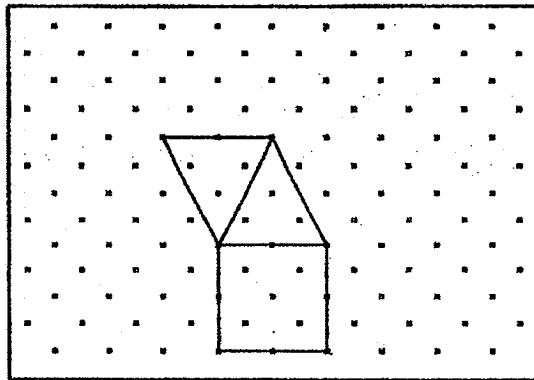

22. A total of 150 boys and girls took part in an Art competition. $\frac{1}{3}$ of the girls and $\frac{1}{6}$ of the boys were prize-winners. The number of boys and girls were not the same. Give your answer in the simplest form.

Each statement below is either true, false, or not possible to tell from the information given. For each statement, put a tick (\checkmark) in the correct column.

Statement	True	False	Not possible to tell
(a) There were twice as many boys as girls who were prize winners.			
(b) $\frac{1}{2}$ of the participants were prize winners.			

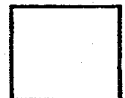

23. The bar graph shows the number of tourists in four different countries on a particular day.

Do not write
in this space

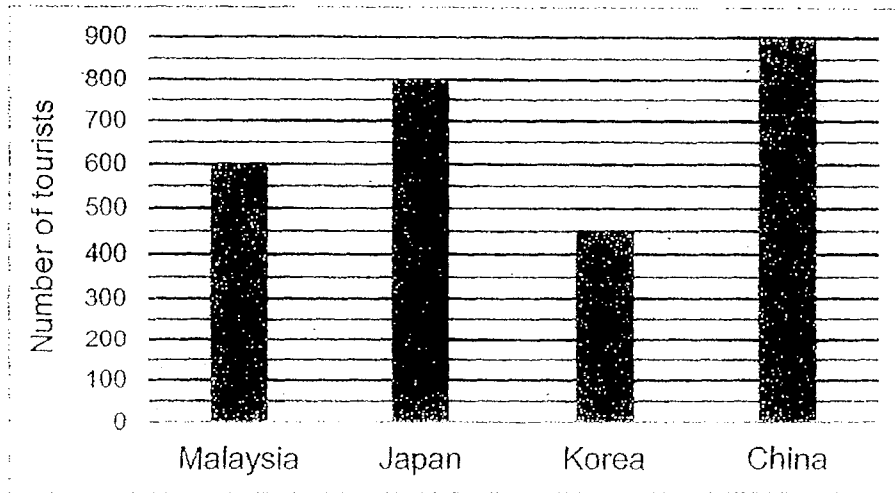

Which country has $\frac{3}{4}$ as many tourists as Malaysia on that day?

Ans: _____

24. The table shows the number of hours spent on tuition by a group of 9 children in a day. What is their average number of hours spent on tuition each day? Give your answer in the simplest form.

Tuition hour per day	0	2	3	4
Number of children	1	4	3	1

Ans: _____ h

25. In the figure, ABCD is a square and EFGC is a rectangle. $\angle BCE = 43^\circ$. Find $\angle GCD$.

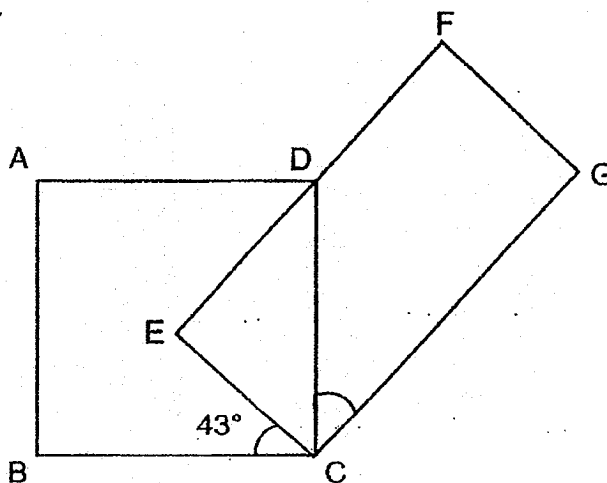

Do not write
in this space

Ans: _____^o

26. The ratio of Julia's money to Mani's money is 2 : 3. The ratio of Mani's money to Kee Lin's money is 4 : 5. Kee Lin has \$30. Find the total sum of money the three girls have.

Ans: \$ _____

27. In the figure, WXY and EFG are identical triangles. The total area of the shaded parts is 80 cm^2 . Find the area of the unshaded part.

Do not write in this space

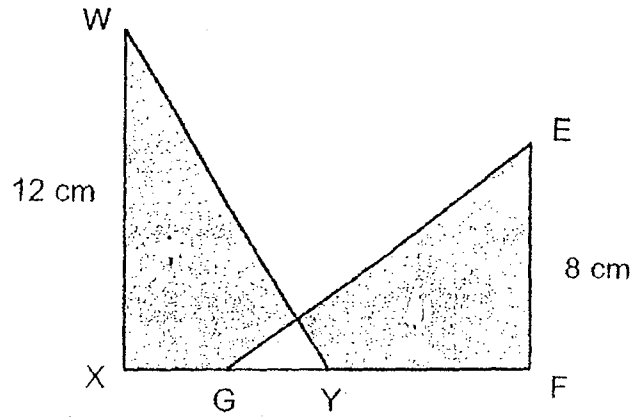

Ans: _____ cm^2

28. The solid below is made up of 1-cm cubes. How many more cubes are needed to make a cube of sides 3 cm?

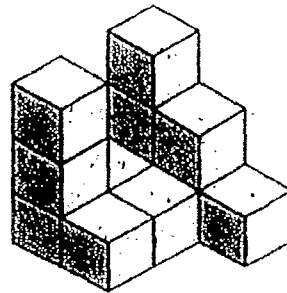

Ans: _____

29. Ali and Beng Huat had the same amount of money at first. After Ali spent \$34, Beng Huat had thrice as much money as Ali. How much money did they have in total at first?

Do not write
in this space

Ans : \$ _____

30. The diagram is made up of a rectangle, triangle and a semicircle. E is the midpoint of the length of the rectangle. The length of the rectangle is 14 cm. Find the area of the shaded region. Take $\pi = \frac{22}{7}$.

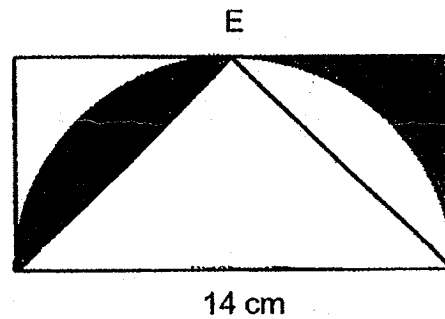

Ans : _____ cm²

END OF PAPER

METHODIST GIRLS' SCHOOL (PRIMARY)
Founded in 1887



PRELIMINARY EXAMINATION 2019
PRIMARY 6
MATHEMATICS

PAPER 2

Duration: 1h 30 min

INSTRUCTIONS TO CANDIDATES

Do not turn over this page until you are told to do so.
Follow all instructions carefully.

Answer all questions.

Write your answers in this booklet.

The use of an approved calculator is expected, where appropriate.

Name: _____ ()

Class: Primary 6. _____

Date: 20 August 2019

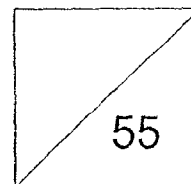

Parent's Signature: _____

Questions 1 to 5 carry 2 marks each. Show your working clearly and write your answers in the spaces provided. For questions which require units, give your answers in the units stated. (10 marks)

Do not write in this space

- 1 For every \$5 that Suzy saved, her father will contribute another \$0.50 to her savings. Suzy's father contributed a total of \$11. What was Suzy's total savings in the end?

Ans: \$ _____

- 2 What is the greatest number of circles, of radius 6 cm, that can be cut from a vanguard sheet measuring 100 cm by 50 cm?

Ans: _____

3 A pencil case costs \$4 more than a sharpener. The total cost of 3 such pencil cases is \$ p .

Do not write
in this space

- (a) Express the cost of 15 such pencil cases in terms of p .
(b) Express the cost of a sharpener in terms of p .

Ans: (a) \$ _____ [1]

(b) \$ _____ [1]



4 The bar graph shows the number of bicycles sold by a shop from June to September. The shop sold a total of 164 bicycles.

The number of bicycles sold in August is not shown in the graph. Draw the bar representing the number of bicycles sold in August.

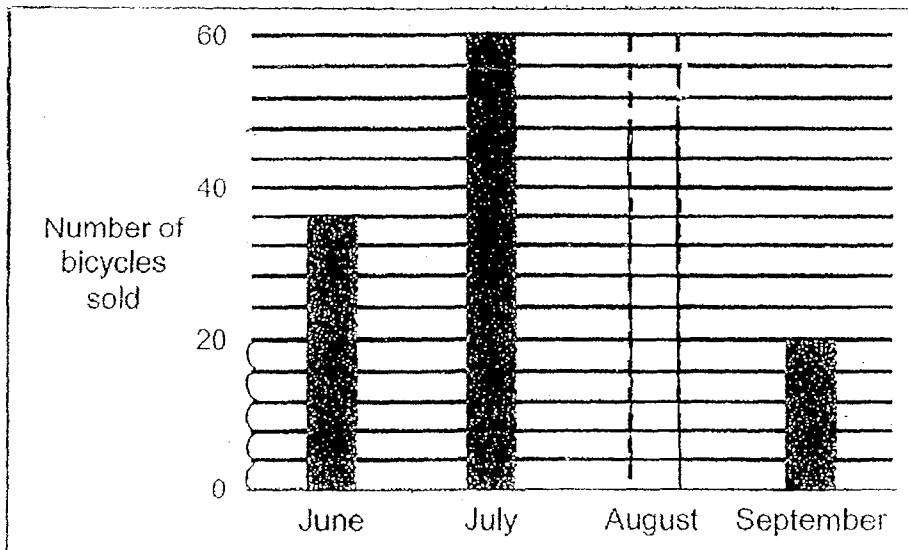

5

The solid below is made up of thirteen 1-cm cubes.

Draw the front view and the side view of the solid on the grids below.

Do not write
in this space

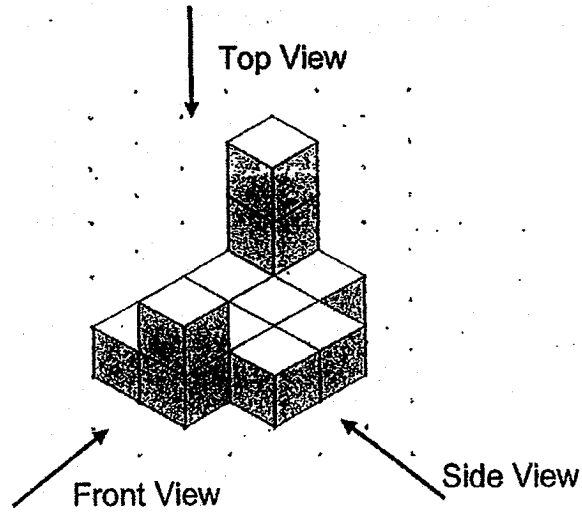

Front View

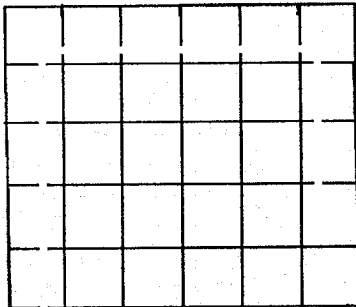

Side View

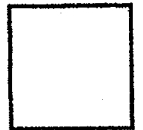
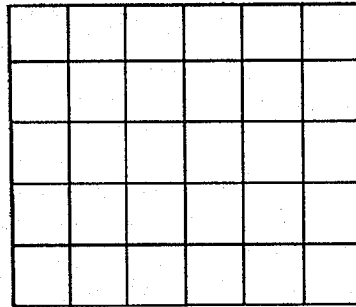

For questions 6 to 17, show your working clearly and write your answers in the space provided. The number of marks available is shown in brackets [] at the end of each question or part-question. (45 marks)

Do not write in this space

- 6 A survey on the places of interest that the pupils in Primary 2 liked was carried out. The results of the survey are shown in the pie chart below.

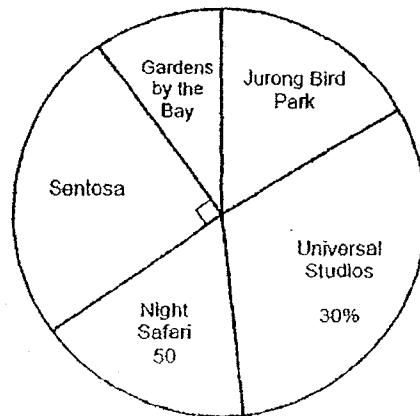

$\frac{1}{6}$ of the pupils surveyed liked the Jurong Bird Park. The number of pupils who liked the Night Safari was the same as the number of pupils who liked the Jurong Bird Park. 30% of the pupils liked Universal Studios.

- (a) How many pupils took part in the survey?
 (b) How many pupils liked Gardens by the Bay?

Ans: (a) _____ [1]

(b) _____ [2]



- 7 Betty and Cathy had 294 stickers altogether. Betty gave away $\frac{3}{8}$ of her stickers and Cathy gave away $\frac{2}{5}$ of her stickers. Both had same number of stickers left. How many stickers did Cathy give away?

Do not write
in this space

Ans: _____ [4]

- 8 At 08 00, a lorry left Town A for Town B moving at a speed of 60 km/h. At 09 00, a car left Town A for Town B moving at a speed of 75 km/h. Both vehicles did not change their speeds throughout. What was the distance travelled by the car when it caught up with the lorry?

Ans: _____ [3]

- 9 A box of chicken wings is 15 kg heavier than a packet of nuggets. The total mass of 5 packets of nuggets and 6 boxes of chicken wings is 189 kg. What is the mass of a box of chicken wings?

Do not write
in this space

Ans: _____ [3]



- 10 Shana has two rectangular boxes of difference sizes. The length, breadth and height of the larger box is twice those of the smaller box. She packed 16 identical cubes exactly into the smaller box. How many such cubes can be packed exactly into the larger box?

Ans: _____ [3]



- 11 In the figure, ABCD is a trapezium and ACF is an isosceles triangle. AED and CEF are straight lines. $\angle AFC = 70^\circ$, $\angle EAC = 20^\circ$ and $\angle ABC = 105^\circ$.

- (a) Find $\angle BAC$.
 (b) Find $\angle AEC$.

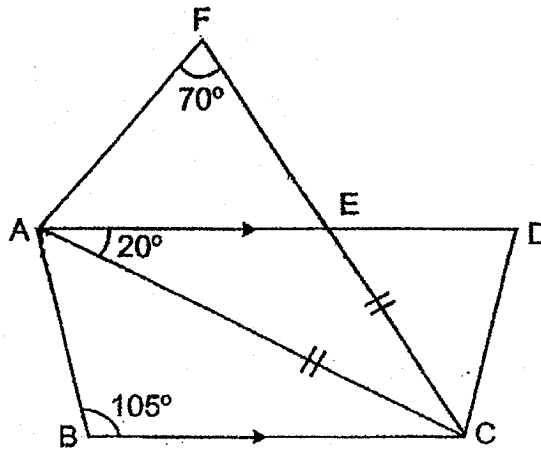

Do not write
in this space

Ans: (a) _____ [2]
 (b) _____ [2]

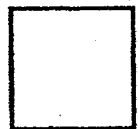

- 12 A shop sells shorts in five different sizes. The table shows the number of shorts sold in January.

Do not write
in this space

Size of shorts	Number of shorts
XS	84
S	152
M	?
L	81
XL	65

- (a) 14% of the shorts sold were in size XS. How many of the shorts sold were in size M?
- (b) In February, there was a 20% decrease in the number of shorts sold in size XL. How many fewer XL shorts were sold in February?

Ans: (a) _____ [2]

(b) _____ [1]

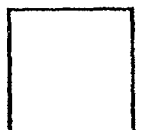

- 13 Tap A and Tap B can fill a tank at a rate of 3 l per minute and 5 l per minute respectively. At first, only Tap A was turned on. When the tank was $\frac{1}{4}$ - filled with water, Tap B was then turned on. Six minutes later, the tank was $\frac{7}{8}$ - filled with water. How much water was there in the tank just before Tap B was turned on?

Do not write
in this space

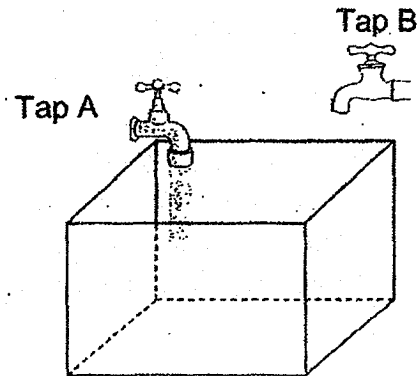

Ans: _____ [4]



14 In the figure below, ABCD is a parallelogram.

Do not write
in this space

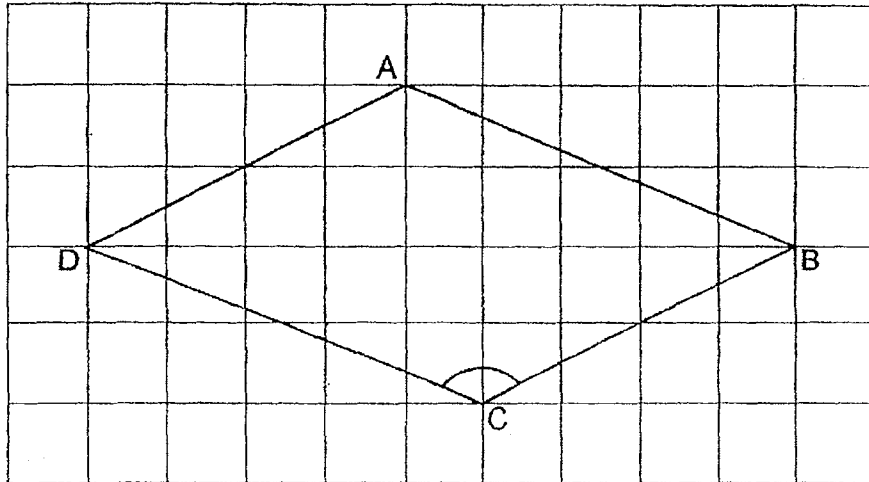

- (a) Draw a line AE perpendicular to DC. [1]
- (b) Measure $\angle BCD$.
- (c) Name the shape formed by figure ABCE.
- (d) Name a pair of parallel lines.

Ans: (b) _____ [1]

(c) _____ [1]

(d) _____ [1]



15 The figure below is made up of a square, 2 identical quarter circles and a semicircle. The sides of the square measure 10 cm. Take $\pi = 3.14$.

Do not write
in this space

- (a) Find the perimeter of the figure.
(b) Find the area of the figure.

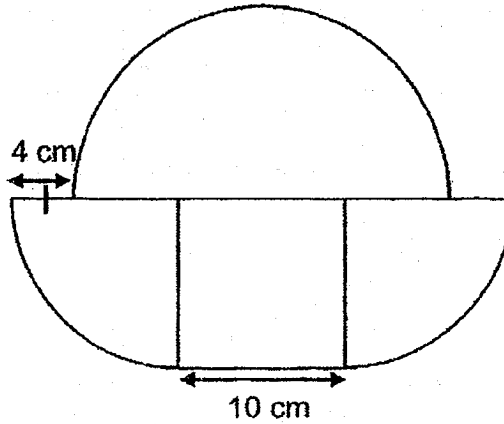

Ans: (a) _____ [2]

(b) _____ [2]



16 In a singing competition, the ratio of male participants to female participants was 1 : 5 at first. After the first round of competition, 25% of the male participants and 60% of the female participants did not make it to the second round. In the second round, there were 15 more female participants than male participants.

Do not write
in this space

- (a) What was the ratio of the number of female participants to the number of male participants in the second round?
(b) How many more female than male participants were there at first?

Ans: (a) _____ [2]

(b) _____ [3]



- 17 Mrs Lim bought an equal number of Brand X and Brand Y correction tapes. She spent \$180 more on Brand Y correction tapes.

Do not write
in this space

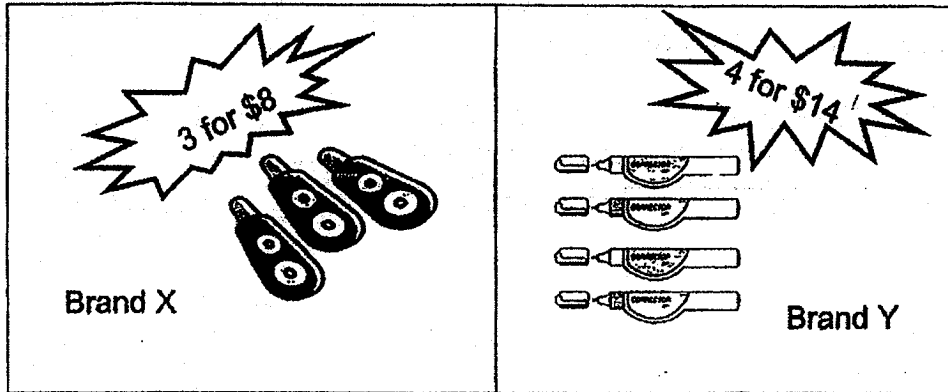

- (a) How many correction tapes did she buy altogether?
(b) How much did she spend on the Brand X correction tapes?

Ans: (a) _____ [3]

(b) _____ [2]



End of Paper

SCHOOL : MGS PRIMARY SCHOOL
 LEVEL : PRIMARY 6
 SUBJECT : MATH
 TERM : 2019 PRELIM

PAPER 1 BOOKLET A

Q 1	Q2	Q3	Q4	Q5	Q6	Q7	Q8	Q9	Q10
2	2	3	4	3	1	2	4	3	3

Q 11	Q12	Q13	Q14	Q15
2	3	1	3	3

PAPER 1 BOOKLET B

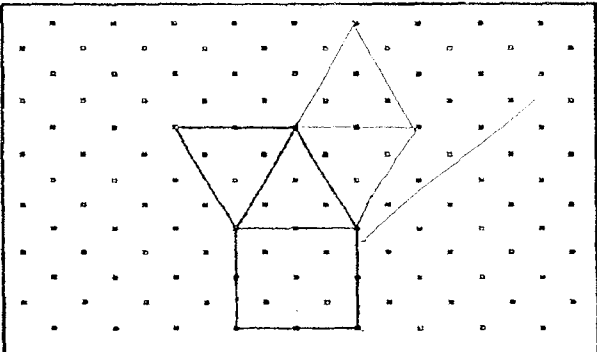
Q16)	$0.14 \times 10 = 1.4$ $1.4 \times 6 = 8.4$
Q17)	$2.35 = 2\frac{35}{100} = 2\frac{7}{20}$
Q18)	$\frac{1}{7}$
Q19)	$50\text{min} \rightarrow \frac{50}{60} \text{h} = \frac{5}{6}$ $18 \times \frac{5}{6} = 15$
Q20)	$9 \times 4 = 36$ $36 - \frac{44}{2} = 36 - 22 = 14$
Q21)	

Q22)	a)Not possible to tell b)False
Q23)	Korea
Q24)	$2\frac{1}{3}h$
Q25)	$90^\circ - 43^\circ = 47^\circ$ $90^\circ - 47^\circ = 43^\circ$
Q26)	$30 \div 15 = 2$ $2 \times 35 = \$70$
Q27)	$96 - 80 = 16$ $16 \div 2 = 8 \text{ cm}^2$
Q28)	$3 \times 3 \times 3 = 27$ $27 - 12 = 15$
Q29)	$34 \div 2 \times 6 = \$102$
Q30)	$14 \times 7 = 98$ $14 \times 7 \times \frac{1}{2} = 49$ $98 - 49 = 49$ $49 \div 2 = 24.5 \text{ cm}^2$

PAPER 2

Q1)	$\$11 \div \$0.50 = 22$ $22 \times \$5 = \110 $\$110 + \$11 = \$121$
Q2)	$100 \div 12 = 8$ $50 \div 12 = 4$ $8 \times 4 = 32$
Q3)	a) $15 \div 3 = 5$ $5 \times \$p = \$(5p)$ b) $\frac{p}{3} - 4 = (\frac{p}{3} - 4)$

Q4)

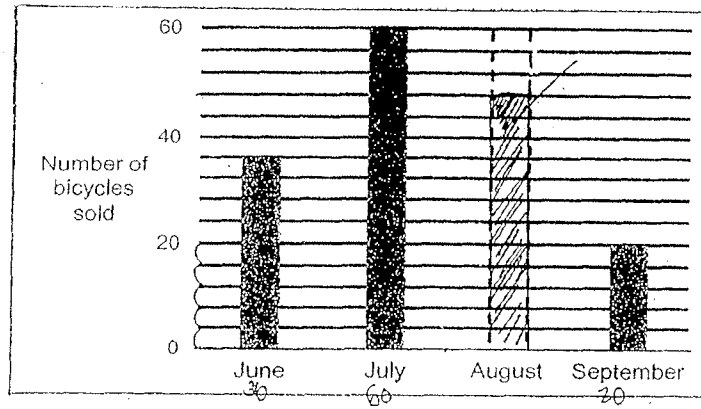

$$164 - 36 - 60 - 20 = 48$$

Q5)

Front View

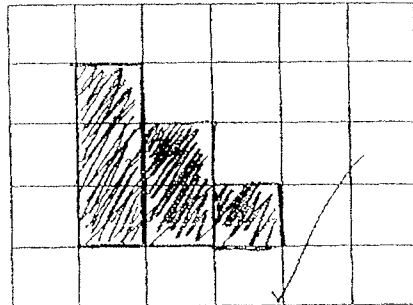

Side View

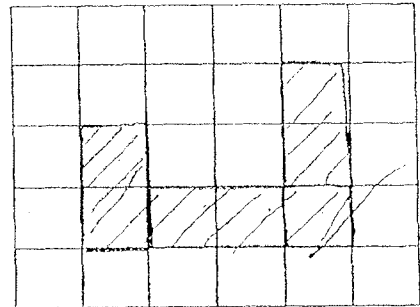

Q6)

a) $50 \times 6 = 300$

b) $\frac{30}{100} \times 300 = 90$

$$\frac{1}{4} \times 300 = 75$$

$$300 - 75 - 90 - 50 - 50 = 35$$

Q7)

Since $\frac{5}{8} \quad \frac{3}{5} \rightarrow \frac{15}{24} \quad \frac{15}{25}$

$$24 + 25 = 49$$

$$294 \div 49 = 6$$

$$6 \times 10 = 60$$

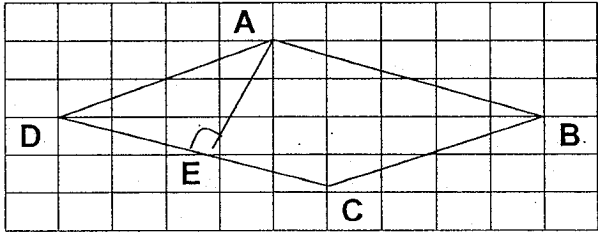
Q8)	$75 - 60 = 15$ $60 \div 15 = 4$ $75 \times 4 = 300\text{km}$
Q9)	$15\text{kg} \times 6 = 90\text{kg}$ $189\text{kg} - 90\text{kg} = 99\text{kg}$ $99\text{kg} \div (5+6) = 9\text{kg}$ $9\text{kg} + 15\text{kg} = 24\text{kg}$
Q10)	$6 \times 6 \times 6 = 216$ $12 \times 12 \times 12 = 1728$ $216 \rightarrow 16$ $1728 \rightarrow \frac{1728}{216} \times 16 = 128$
Q11)	a) $180^\circ - 20^\circ - 105^\circ = 55^\circ$ b) $70^\circ - 20^\circ = 50^\circ$ $180^\circ - 50^\circ - 70^\circ = 60^\circ$ $180^\circ - 60^\circ = 120^\circ$
Q12)	a) $84 \div 14 \times 100 = 600$ $600 - 84 - 152 - 81 - 65 = 218$ b) $65 \div 100 \times 80 = 52$ $65 - 52 = 13$
Q13)	$5\text{L} \times 6 = 30\text{L}$ $3\text{L} \times 6 = 18\text{L}$ } 6min $\frac{7}{8} - \frac{2}{8} = \frac{5}{8}$ $18\text{L} + 30\text{L} = 48\text{L}$ $48\text{L} \div 5 \times 2 = 19.2\text{L}$
Q14)	a) 
Q14)	b) 131° c) Trapezium d) $DC \parallel AB$

Q15)	<p>a) Arc of quadrant = $2\pi r \times \frac{1}{4}$ $= 2 \times 3.14 \times 10 \times \frac{1}{4} = 15.7$ Arc of semicircle = $2 \pi r \times \frac{1}{2}$ $= 2 \times 3.14 \times 11 \times \frac{1}{2} = 34.54$ $34.54 + 4 + 15.7 + 10 + 15.7 + 4 = 83.94\text{cm}$</p> <p>Quadrant</p> <p>b) $\pi r^2 = 3.14 \times 10 \times 10 \times \frac{1}{2} = 157$ square $10 \times 10 = 100$ Semicircle $\pi r^2 = 3.14 \times 11 \times 11 \times \frac{1}{2} = 189.97$ $189.97 + 100 + 157 = 446.97 \text{ cm}^2$</p>		
Q16)	<table style="width: 100%; border: none;"> <tr> <td style="width: 50%; border: none;"> <p>a) $40u - 15u = 25u$ $15 \div 25 \times 40 = 24$ $15 \div 25 \times 15 = 9$</p> <p>b) $100u - 20u = 80u$ $15 \div 25 \times 80 = 48$</p> </td> <td style="width: 50%; border: none; vertical-align: top;"> <p>F : M 24 : 9 8 : 3 (ans)</p> </td> </tr> </table>	<p>a) $40u - 15u = 25u$ $15 \div 25 \times 40 = 24$ $15 \div 25 \times 15 = 9$</p> <p>b) $100u - 20u = 80u$ $15 \div 25 \times 80 = 48$</p>	<p>F : M 24 : 9 8 : 3 (ans)</p>
<p>a) $40u - 15u = 25u$ $15 \div 25 \times 40 = 24$ $15 \div 25 \times 15 = 9$</p> <p>b) $100u - 20u = 80u$ $15 \div 25 \times 80 = 48$</p>	<p>F : M 24 : 9 8 : 3 (ans)</p>		
Q17)	<p>a) $\\$42 - \\$32 = \\$10$ $\\$180 \div \\$10 = 18$ $12 \times 18 = 216$ $12 \times 18 = 216$ $216 \times 2 = 432$</p> <p>b) $216 \div 12 = 18$ $18 \times 32 = \\$576$</p>		



NAN HUA PRIMARY SCHOOL
PRELIMINARY EXAMINATION – 2019
PRIMARY 6

MATHEMATICS
PAPER 1
(BOOKLET A)

Total Time for Booklets A and B: 1 hour

INSTRUCTIONS TO CANDIDATES

1. Write your name and index number in the space provided.
2. Do not turn over the page until you are told to do so.
3. Follow all instructions carefully.
4. Answer all questions.
5. Shade your answers in the Optical Answer Sheet (OAS) provided for Questions 1-15.
6. The use of calculators is **NOT** allowed.

Name : _____ ()

Class : 6 _____

Date : 22 August 2019

Parent's Signature: _____

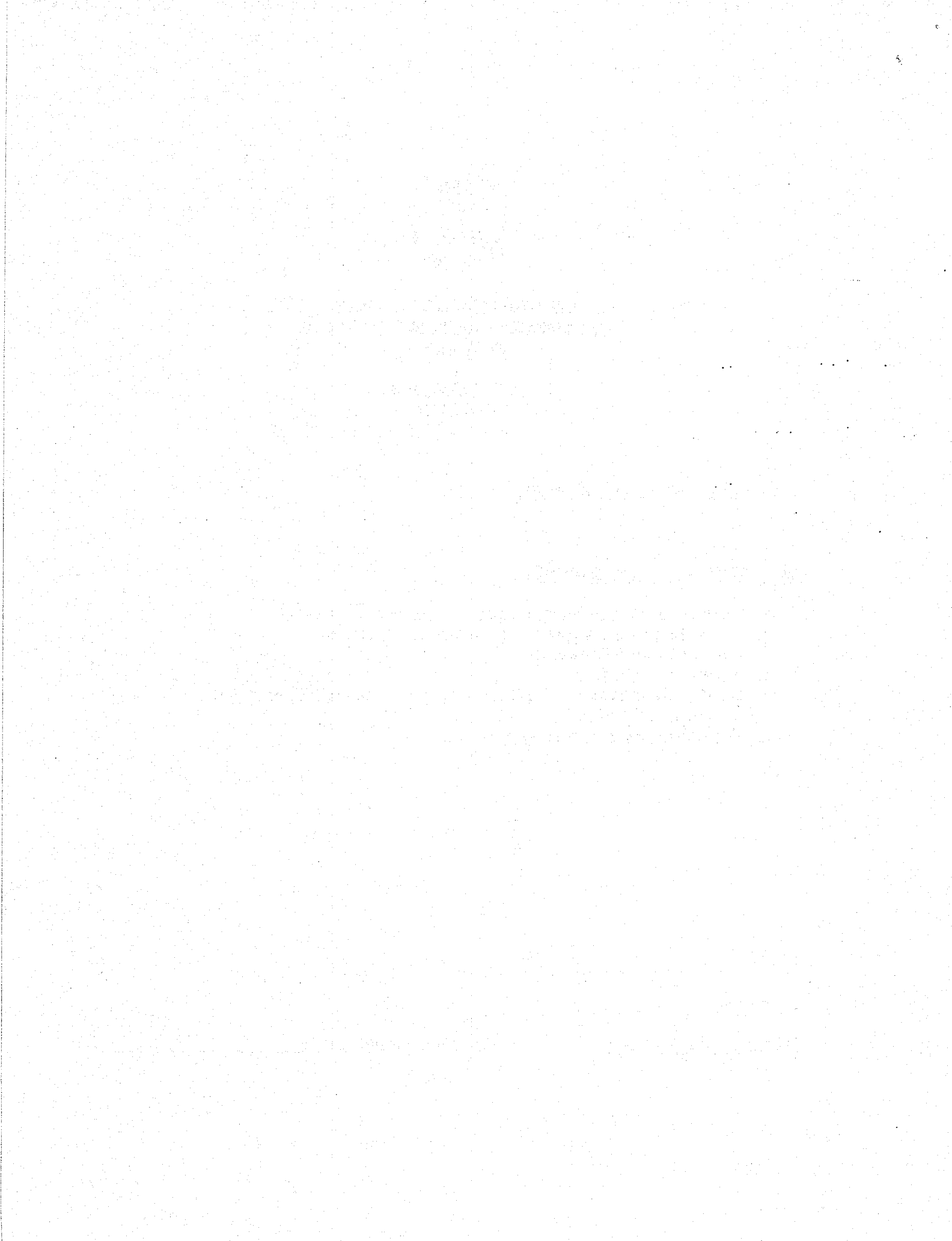

Questions 1 to 10 carry 1 mark each. Questions 11 to 15 carry 2 marks each. For each question, four options are given. One of them is the correct answer. Make your choice (1, 2, 3 or 4) and shade the oval (1, 2, 3 or 4) on the Optical Answer Sheet. (20 marks)

1. Express 759.285 to the nearest hundredth.

- (1) 759.28
- (2) 759.29
- (3) 760
- (4) 800

2. Which two lines are parallel to each other?

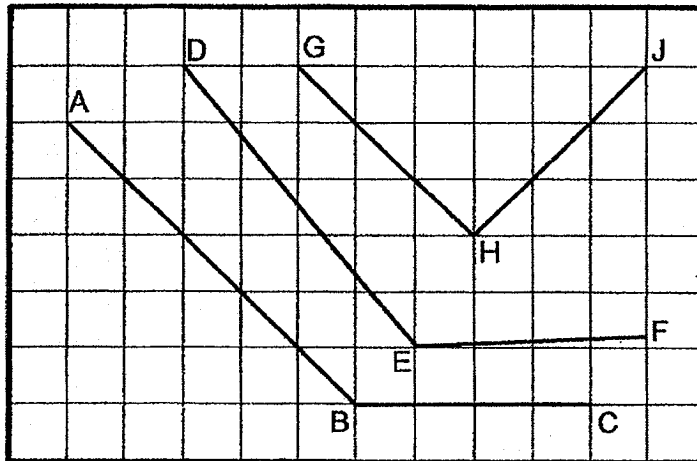

- (1) AB and DE
- (2) AB and GH
- (3) GH and HJ
- (4) BC and EF

3. What is the mass of the durian shown?

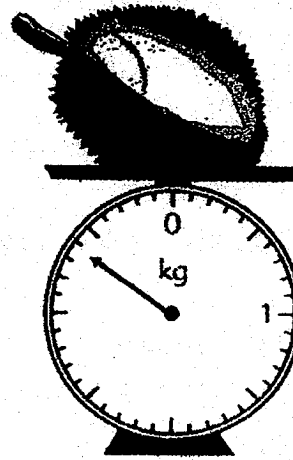

- (1) 3 kg 40 g
- (2) 3 kg 60 g
- (3) 3.4 kg
- (4) 4.6 kg

4. Which one of the following is the most likely mass of your Student's Diary 2019?

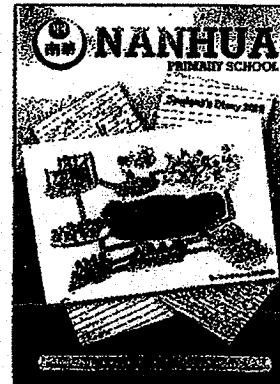

- (1) 20 g
- (2) 2 g
- (3) 200 g
- (4) 2000 g

5. $600 + 6 + \frac{6}{100} + \frac{6}{1000} = \underline{\hspace{2cm}}$.

- (1) 66.666
- (2) 606.066
- (3) 606.66
- (4) 6666

6. Simplify $12a + 8 - a - 3 + 2a$.

- (1) $9a + 5$
- (2) $13a + 5$
- (3) $13a + 11$
- (4) $15a + 11$

7. A, B, C, D are points on a square grid.
Which point when joined to P and Q forms an obtuse-angled triangle?

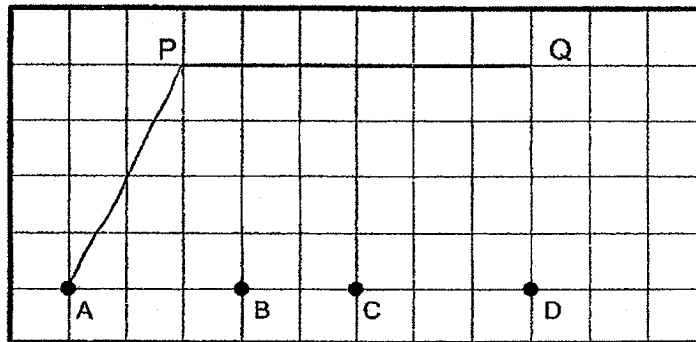

- (1) A
- (2) B
- (3) C
- (4) D

8. Arrange the following distances from the shortest to the longest.

4.3 km	$4\frac{3}{4}$ km	430 m
--------	-------------------	-------

- | | <u>Shortest</u> | | <u>Longest</u> | | |
|-----|-------------------|---|-------------------|---|-------------------|
| (1) | 4.3 km | , | $4\frac{3}{4}$ km | , | 430 m |
| (2) | 430 m | , | $4\frac{3}{4}$ km | , | 4.3 km |
| (3) | $4\frac{3}{4}$ km | , | 430 m | , | 4.3 km |
| (4) | 430 m | , | 4.3 km | , | $4\frac{3}{4}$ km |

9. The ratio of the number of boys to the number of girls to the number of adults at a fun fair is 6 : 3 : 2. What is the ratio of the number of adults to the number of children?

- (1) 2 : 9
- (2) 2 : 11
- (3) 9 : 2
- (4) 11 : 2

10. 20% of a number is 80. What is the number?

- (1) 16
- (2) 40
- (3) 160
- (4) 400

11. Which one of the following fractions is nearest to $\frac{1}{2}$?

- (1) $\frac{2}{3}$
- (2) $\frac{3}{4}$
- (3) $\frac{2}{5}$
- (4) $\frac{3}{7}$

12. The figure below is formed by joining two quarter circles of radius 7 cm. Find the perimeter of the figure. (Take $\pi = \frac{22}{7}$)

- (1) 22 cm
- (2) 36 cm
- (3) 43 cm
- (4) 77 cm

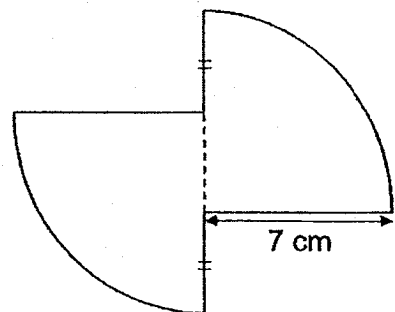

13. John had some sweets. After he gave 8 sweets to Pei Ling, they had the same number of sweets. How many sweets did John have at first. Let m be the number of sweets Pei Ling had a first.

- (1) m
- (2) $m + 4$
- (3) $m + 8$
- (4) $m + 16$

14. Two figures, P and Q, are shown in the square grid below.

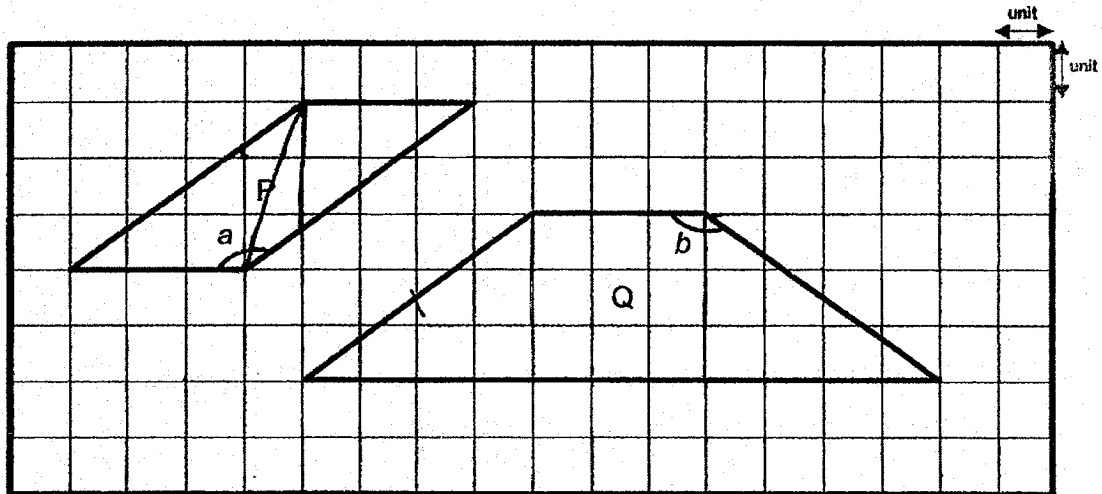

Which of the statement(s) is/are true?

- A. $\angle a = \angle b$
- B. The perimeter of Figure Q is 8 units more than the perimeter of Figure P.
- C. The area of Figure Q is 4 times of the area of Figure P.

- (1) A only
- (2) B only
- (3) A and B
- (4) A and C

15. A repeated pattern is formed using the numbers 0, 1, 2 and 3.
The first 19 numbers are shown below.

1	3	2	0	1	1	3	2	0	1	1	3	2	0	1	1	3	2	0	...
1 st	2 nd																		19 th

What is the sum of the first 403 numbers?

- (1) 560
- (2) 563
- (3) 564
- (4) 566

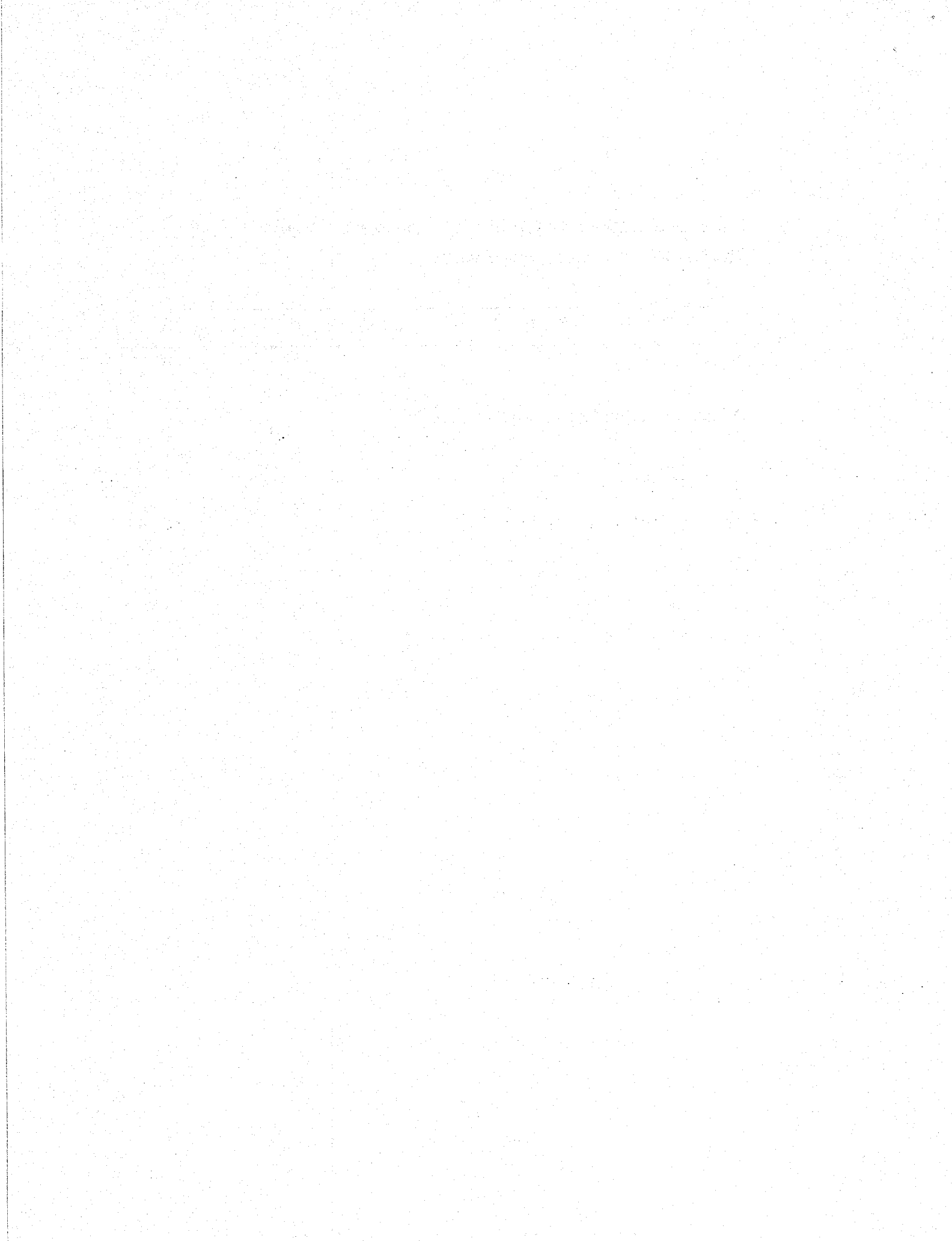



**NAN HUA PRIMARY SCHOOL
PRELIMINARY EXAMINATION – 2019
PRIMARY 6**

**MATHEMATICS
PAPER 1
(BOOKLET B)**

Total Time for Booklets A and B: 1 hour

INSTRUCTIONS TO CANDIDATES

1. Write your name and index number in the space provided.
2. Do not turn over the page until you are told to do so.
3. Follow all instructions carefully.
4. Answer all questions.
5. Write your answers in this booklet.
6. The use of calculators is **NOT** allowed.

Marks Obtained

Paper 1	Booklet A		/ 45
	Booklet B		
Paper 2			/ 55
Total			/ 100

Name : _____ ()

Class : 6 _____

Date : 22 August 2019

Parent's Signature: _____

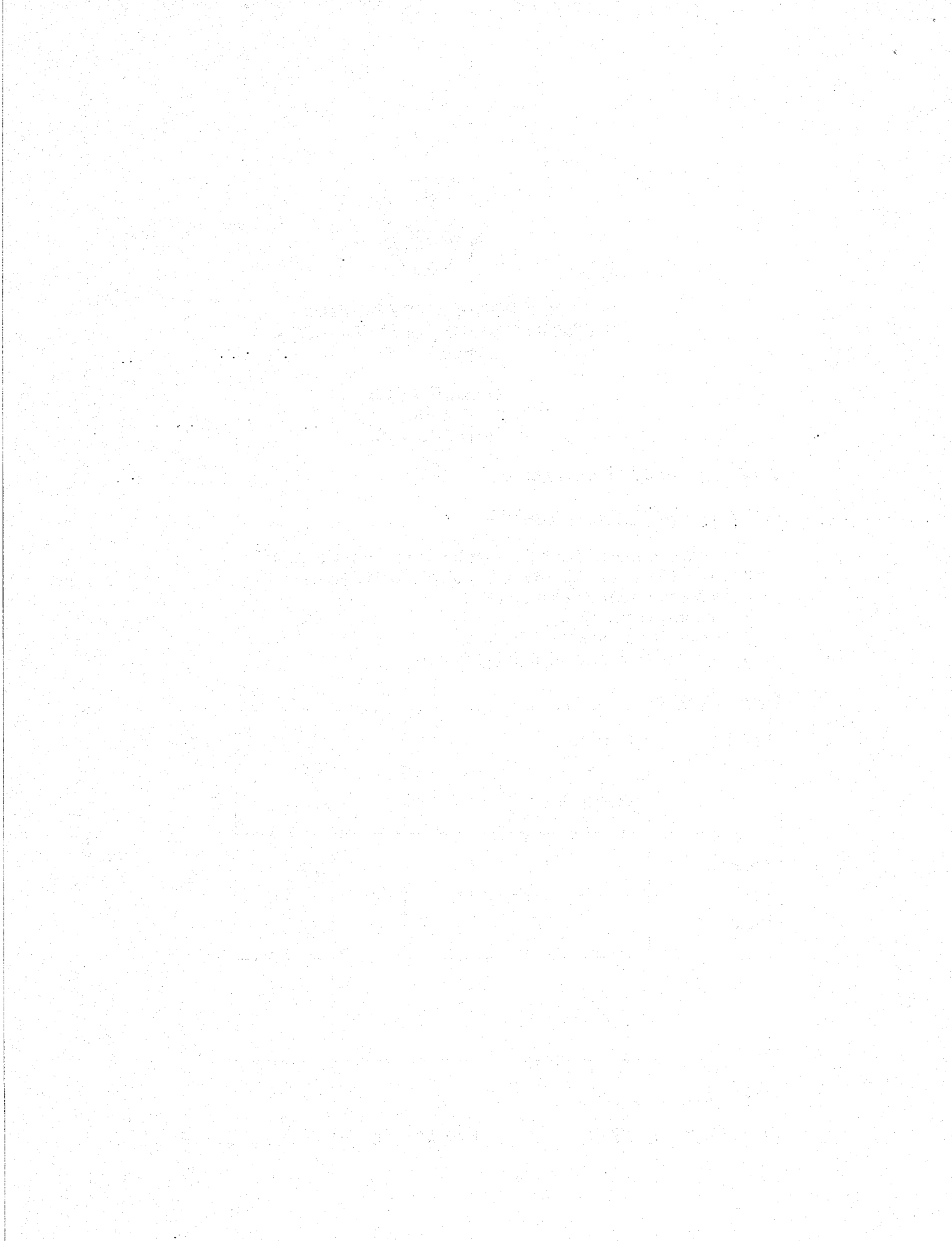

Questions 16 to 20 carry 1 mark each. Write your answers in the spaces provided.
For questions which require units, give your answers in the units stated.

(5 marks)

Do not write
in this space

16. Write one million, two hundred and four thousand and five hundred in numerals.

Ans: _____

17. Find the value of $10 \div 2000$. Give your answer in decimal.

Ans: _____

18. There are 6 shaded squares in the figure. Shade 2 more squares to form a symmetric figure with AB as the line of symmetry.

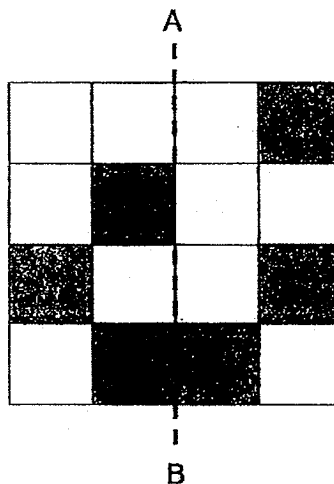

19. Express 12.5% as a fraction in its simplest form.

Do not write
in this space

Ans: _____

20. The figure below shows a road map.

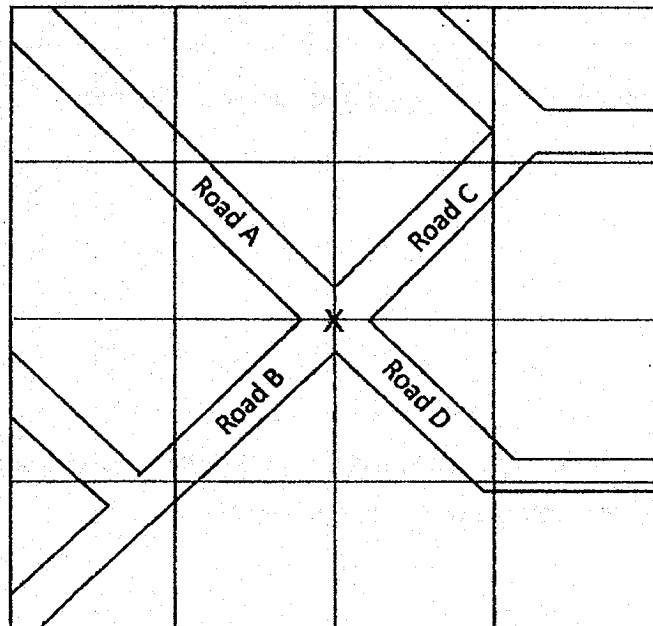

Jerry approached the cross junction 'X' in a car from one of the roads.
He turned his car 90° clockwise onto Road B.
Which road was he coming from before he turned onto Road B?

Ans: _____

Questions 21 to 30 carry 2 marks each. Show your working clearly in the space provided for each question and write your answers in the spaces provided. For each questions which require units, give your answers in the units stated.

(20marks)

Do not write
in this space

-
21. The Tan family drove from Singapore to Malaysia.
They left Singapore at 10.45 a.m. and travelled for 2 h 25 min.
What time did they arrive in Malaysia? Give your answer in 24 h clock.

Ans: _____

-
22. Find the value of $3 \div 7$. Give your answer correct to 2 decimal places.

Ans: _____

23. a) Which of the following solids is a prism?

Do not write
in this space

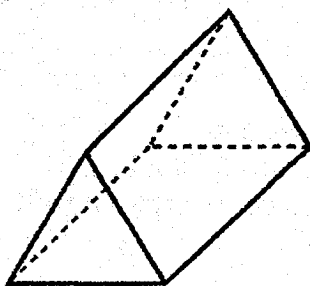

Solid A

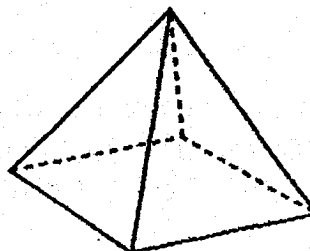

Solid B

Ans: _____



a) The net drawn for the solid below is incorrect.
Which triangle (A,B or C) does not fit the net of the solid?

Solid	Net

Ans: _____



24. a) Complete the cuboid on the isometric grid.

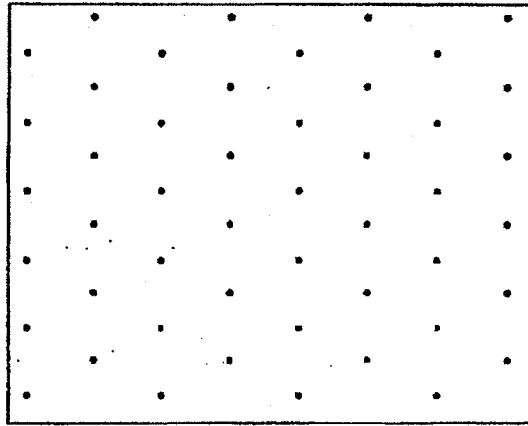
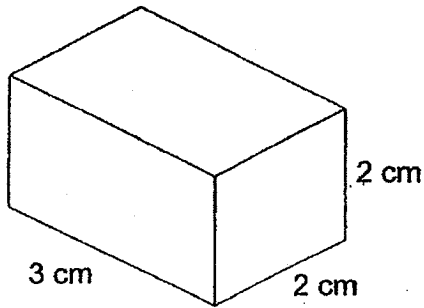

Do not write
in this space



b) Which of the following figures represents the side view of the solid?

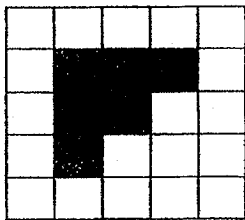
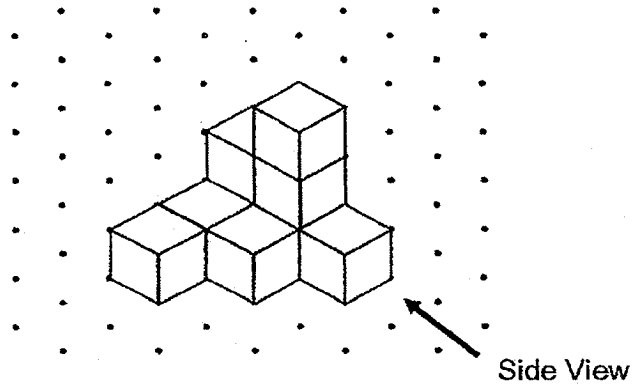

A

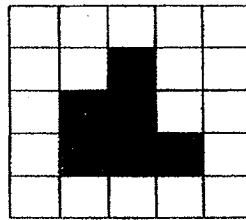

B

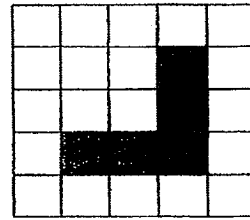

C

Ans: _____



25. Jenny had some milk. She drank $\frac{1}{5}$ litres of milk and used $\frac{1}{2}$ litres of milk to bake cakes. After that, she had 2 litres of milk left. How many litres of milk did she have at first?

Do not write
in this space

Ans: _____ l

26. Car A travelled 45 km in $\frac{1}{2}$ h. Car B travelled 150 km in 2 h.
Which car travelled at a slower average speed?

Ans: _____

27. The average number of stickers Henry collected in five days is 8. The table below shows the number of stickers Henry collected in five days. How many stickers did he collect on Wednesday?

Day	Mon	Tues	Wed	Thurs	Fri
Number of Stickers	5	0	?	12	10

Ans: _____

28. In the figure below, ABEF is a rhombus and ABC is a triangle. $\angle CAE = 20^\circ$. $\angle CBE = 43^\circ$. $\angle AEF = 55^\circ$. $\angle ADE = 105^\circ$.

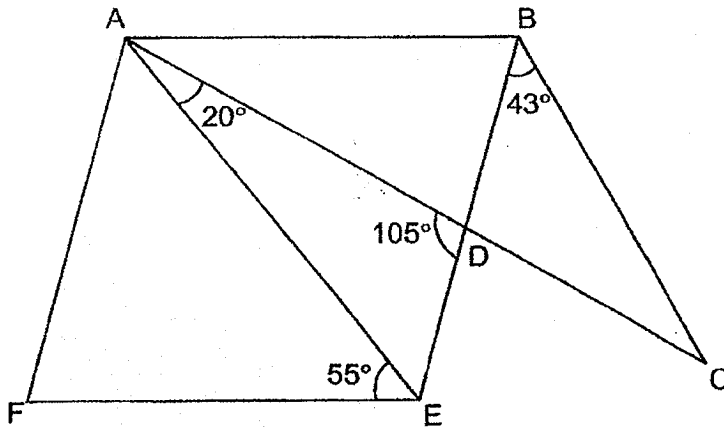

Each statement below is either true, false or not possible to tell from the information given. For each statement, put a tick (\checkmark) in the correct column.

Statement	True	False	Not possible to tell
ABE is an isosceles triangle.			
ABC is an isosceles triangle.			

Do not write in this space



29. Joshua had a rectangular block of wood 8 cm by 4 cm by 3 cm. He painted all the faces of the block. He cut the block into 1-cm cubes. How many of the cubes did not have any of its faces painted?

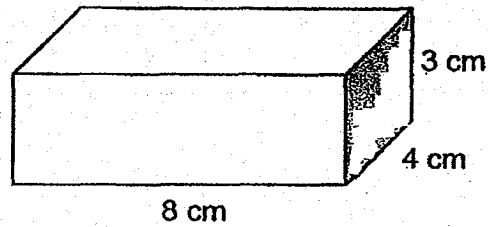

Ans: _____

Do not write
in this space



30. The figure is formed by overlapping 2 semicircles of radius 7 cm. The overlapped area is 60 cm^2 .

Find the area of the figure. (Take $\pi = \frac{22}{7}$)

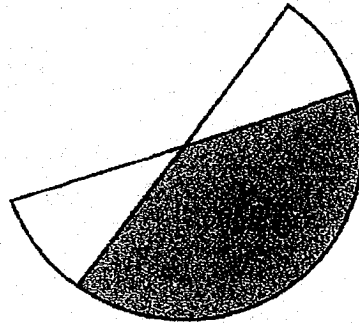

Ans: _____ cm^2



END OF PAPER



**NAN HUA PRIMARY SCHOOL
PRELIMINARY EXAMINATION – 2019
PRIMARY 6**

MATHEMATICS

Paper 2

Total Time for Paper 2: 1 hour 30 minutes

5 Short Answer Questions (10 marks)

12 Structured / Long Answer Questions (45 marks)

INSTRUCTION TO CANDIDATES

1. Write your name and index number in the space provided.
2. Do not turn over the page until you are told to do so.
3. Follow all instructions carefully
4. Answer all questions and show your workings clearly.
5. You are allowed to use a calculator.

Marks Obtained

Total		/ 55
--------------	--	-------------

Name : _____ ()

Class : 6 _____

Date : 22 Aug 2019

Parent's Signature : _____

Questions 1 to 5 carry 2 marks each. Show your working clearly and write your answers in the space provided. For questions which require units, give your answers in the units stated. (10 marks)

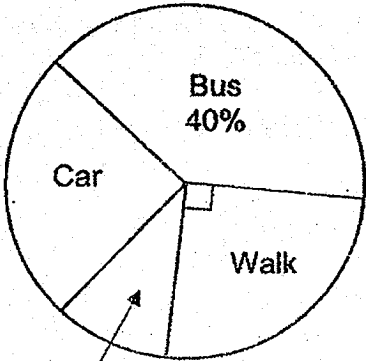
<p>1.</p>	<p>The pie chart below shows the different ways 120 students go to school. How many students go to school by car?</p>  <p>MRT $\frac{1}{10}$</p> <p>Ans: _____</p>	<p>Do not write in this space</p> <input data-bbox="1327 990 1473 1052" type="text"/>
<p>2.</p>	<p>Janice mixed 750 ml of orange squash with 2250 ml of water to make orange juice. She poured the orange juice into some identical bottles. The capacity of each bottle is 800 ml. What was the least number of bottles she used to contain all the orange juice?</p> <p>Ans: _____</p>	<input data-bbox="1327 1783 1473 1846" type="text"/>

3.

Mrs Lim is 35 years old now. Her son is m years younger than her.
What is the sum of their ages 2 years ago?
Express your answer in terms of m .

Do not
write in
this space

Ans: _____ years old

4.

The table shows the charges for booking a badminton court at a community centre.

Time	Charge
9 a.m. – 6 p.m.	\$3.50 per hour
6 p.m. – 10 p.m.	\$7.20 per hour

Benny booked a badminton court from 4 p.m. to 8 p.m.
How much did he have to pay?

Ans: \$ _____

5. Mrs Tan pinned a piece of cloth onto the class notice board using some pins. The figure below shows part of the notice board. Pins are placed at an equal distance on the perimeter of the notice board. The distance between every 2 pins is 10 cm. Pins are placed at the 4 corners of the notice board. How many pins are used?

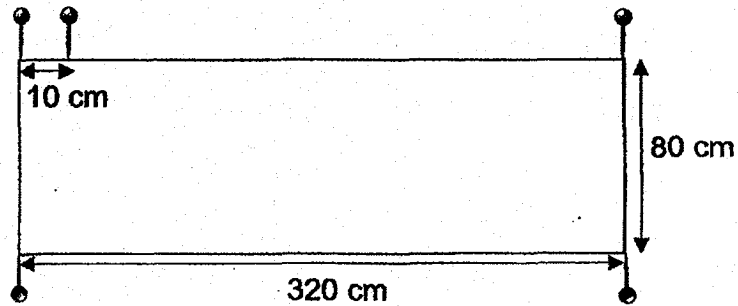

Do not write in this space

Ans: _____

For questions from 6 to 17, show your working clearly and write your answers in the spaces provided. The number of marks available is shown in brackets [] at the end of each question or part-question. (45 marks)

6. The usual price of a dining table was \$950. During the Great Singapore Sale, the price of the dining table was reduced by 20%. Jane bought the dining table during the sale. She also paid an additional 7% GST on the discounted price. How much did Jane pay for the dining table in total?

Do not write in this space

Ans: _____ [3]

7. In the figure below, $ABFG$ is a square, $CDEF$ is a rectangle and DEG is a triangle. $AG = 5\text{ cm}$, $CD = 4\text{ cm}$ and $DE = 7\text{ cm}$. What is the area of the shaded part?

Do not write in this space

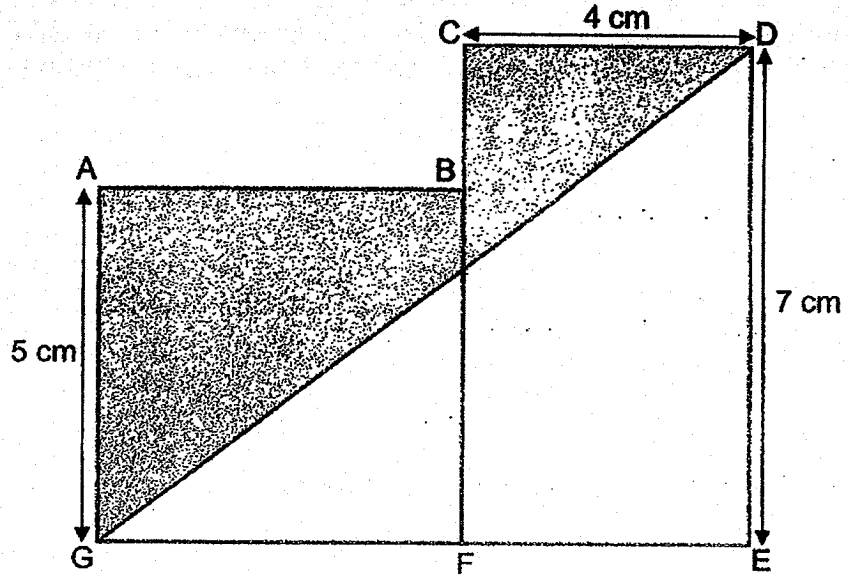

Ans: _____ [3]

8. Tom and Jerry started jogging from the same start point of a 4 km track round a park. They started at the same time but in opposite directions. Both of them did not change their speed throughout. Jerry jogged at a slower speed than Tom. After 20 min, Tom jogged 3200 m. Jerry was 2000 m away from him. What was Jerry's jogging speed in m/min?

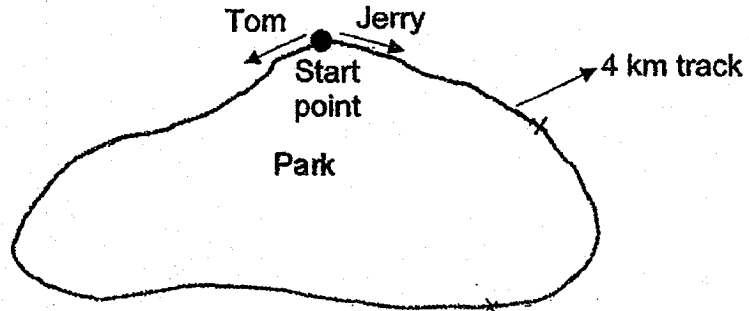

Do not write in this space

Ans: _____ [3]

9. Jie Yi had a square piece of paper. She made 2 folds from the corner to the diagonal line as shown below.

Do not write in this space

- a) Find $\angle x$.
- b) Find $\angle y$.

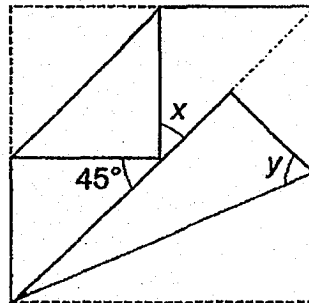
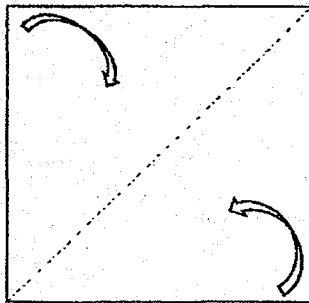

Ans: a) _____ [1]

b) _____ [2]



10. Janice bought some cakes and muffins at the prices shown below.

Do not
write in
this space

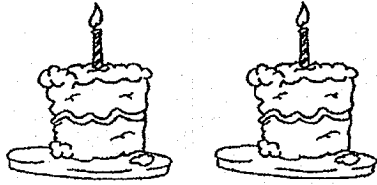

Cakes
2 for \$9



Muffins
3 for \$8

She bought an equal number of cakes and muffins.
She spent \$55 more on cakes than muffins. How many cakes and muffins
did she buy altogether?

Ans: _____ [4]

11. Amy spends \$2400 each month. Her spending each month is represented by the bar graph below. The bars for the amount spent on rent and transport have not been drawn.

Do not write in this space

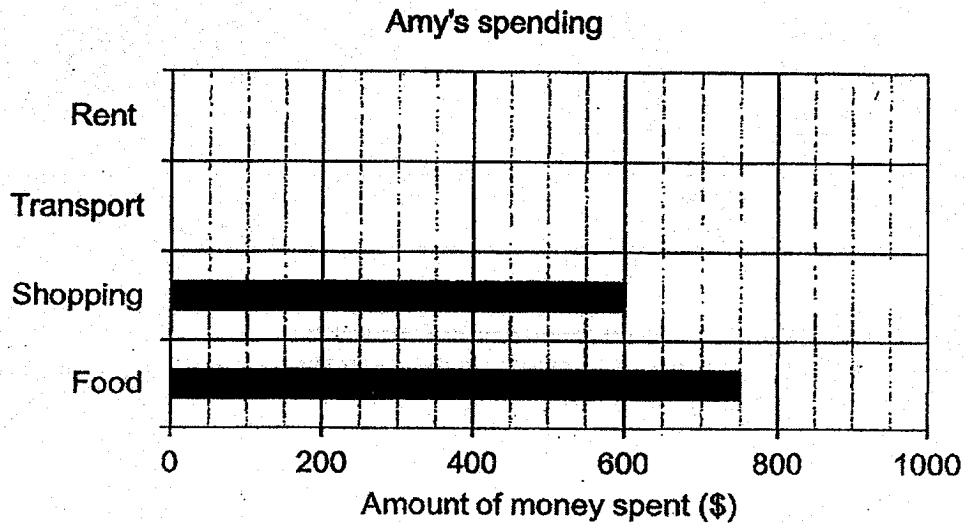

- What percentage of her spending did Amy spend on shopping?
- What fraction of her spending did she spend on food? Express your answer in the simplest form.
- Amy spends more money on rent than on shopping. She spends the most amount of money on food.

Write down one possible set of values for the amount of money she spent on rent and transport. The values can only be multiples of 10.

Ans: a) _____ [1]

b) _____ [1]

c) Rent: _____

Transport: _____ [2]

12. Mr Lee is a salesman. He had 300 bottles of shampoo. The line graph shows the number of bottles of shampoo left unsold at the end of each month.

Do not write in this space

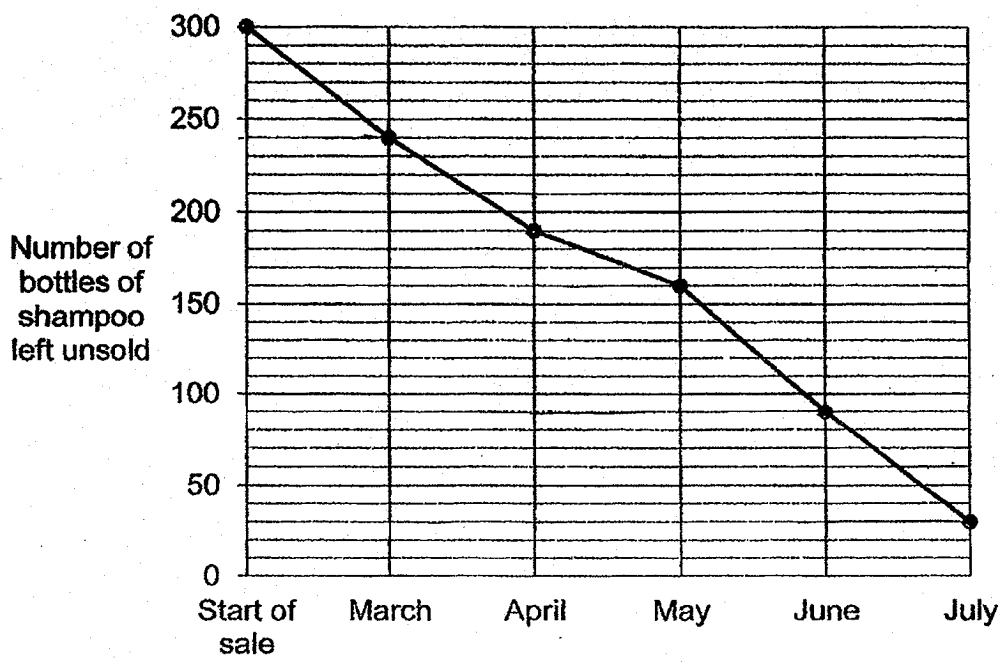

- a) In which month was the most number of bottles of shampoo sold?
- b) What was the percentage decrease in the number of bottles sold in May compared to April?

Ans: a) _____ [2]

b) _____ [2]

13. At a concert, \$11 500 was collected from the sale of tickets. The amount collected from the sale of child tickets is \$3500 more than the sale of adult tickets.

- a) How much was collected from the sale of adult tickets?
- b) The ratio of the number of adults to the number of children is 1 : 3. The cost of an adult ticket is \$30 more than the cost of a child ticket. How many adult tickets were sold?

Do not write in this space

Ans: a) _____ [1]

b) _____ [3]

14. In the figure below, ABCD is a parallelogram.
O is the centre of the circle.

- a) Find $\angle DBO$.
- b) Find $\angle OBC$.
- c) Find $\angle DAB$.

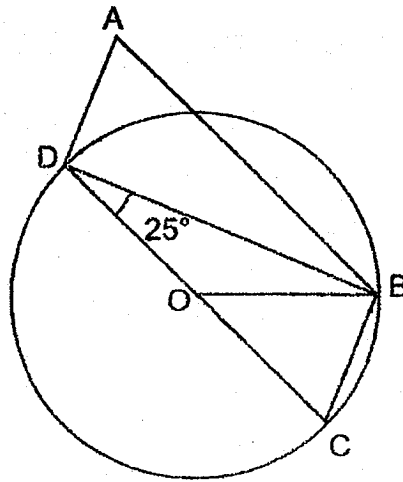

Do not
write in
this space

Ans: a) _____ [1]

b) _____ [2]

c) _____ [1]

15. The participants of a competition are divided equally into 2 groups, Group A and Group B. In Group A, there are 30 more boys than girls. In Group B, there are 18 more girls than boys. $\frac{3}{7}$ of all the participants are girls. How many participants are boys?

Do not
write in
this space

Ans: _____ [3]

16. The figure below shows 2 containers, A and B.
Container A is rectangular and contains 54 ℓ of water.
Container B is cubical and empty at first.

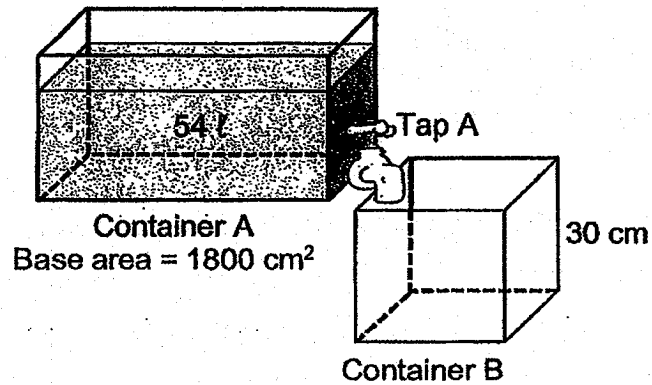

- a) Find the height of water in Container A.
b) Tap A is turned on. Tap A allows water to flow from container A to B at a rate of 3 ℓ per min. How long will it take for height of the water level in both containers to be the same?

Ans: a) _____ [1]

b) _____ [4]

Do not
write in
this space

17. In the figures below, the shaded and unshaded dots follow a pattern.

Do not write in this space

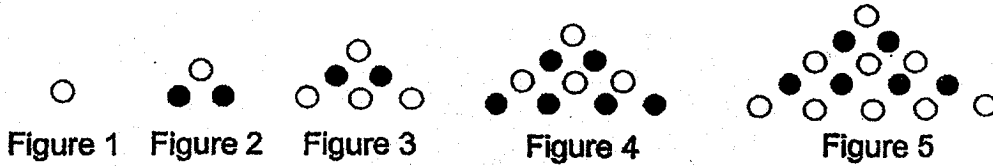

(a) Study the above figures and complete the table for Figure 6.

Figure number	Number of unshaded dots	Number of shaded dots	Total number of dots
1	1	0	1
2	1	2	3
3	4	2	6
4	4	6	10
5	9	6	15
6	(i)	(ii)	(iii)

(b) What is the total number of dots in Figure 50?

Ans: a) (i) _____

(ii) _____

(iii) _____ [3]

b) _____ [2]

– End of Paper 2 –

SCHOOL : NAN HUA PRIMARY SCHOOL
 LEVEL : PRIMARY 6
 SUBJECT : MATH
 TERM : 2019 PRELIM

PAPER 1 BOOKLET A

Q 1	Q2	Q3	Q4	Q5	Q6	Q7	Q8	Q9	Q10
2	2	3	3	2	2	1	4	1	4

Q 11	Q12	Q13	Q14	Q15
4	3	4	3	4

PAPER 1 BOOKLET B

Q16)	1204500
Q17)	$10 \div 2000 = 0.005$
Q18)	<div style="text-align: center;"> </div>
Q19)	$12.5\% = \frac{12.5}{100} \times 2$ $= \frac{25}{200} \div 5$ $= \frac{5}{40} \div 5 = \frac{1}{8}$
Q20)	Road A
Q21)	13:10pm
Q22)	0.43

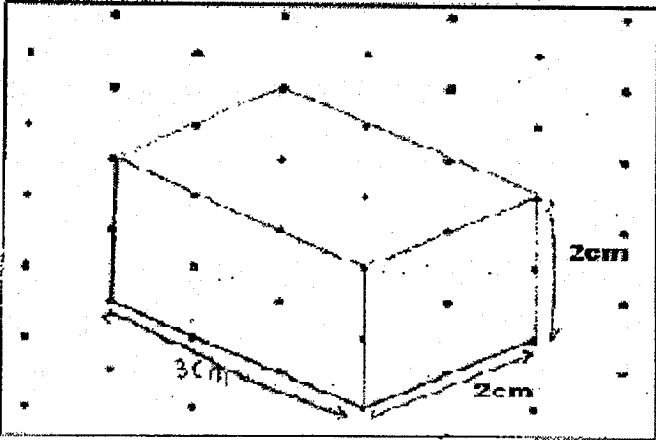
Q23)	a) Solid A b) B										
Q24)	<p>a)</p>  <p>b) C</p>										
Q25)	$\frac{1}{5}l \times 2 = \frac{2}{10}l = 0.2l$ $2l + 0.5l + 0.2l = 2.7l$	$\frac{1}{2}l \times 5 = \frac{5}{10}l = 0.5l$									
Q26)	<p><u>Car A</u></p> $s = \frac{45km}{\frac{1}{2}h}$ <p>=90km/h</p>	<p><u>Car B</u></p> $s = \frac{150km}{2h}$ <p>=75km/h</p> <p>Ans : Car B</p>									
Q27)	$8 \times 5 = 40$ $40 - 5 - 12 - 10 - 0 = 13$										
Q28)	<table border="1" data-bbox="424 1427 1169 1576"> <thead> <tr> <th>True</th> <th>False</th> <th>Not</th> </tr> </thead> <tbody> <tr> <td>√</td> <td></td> <td></td> </tr> <tr> <td></td> <td>√</td> <td></td> </tr> </tbody> </table>		True	False	Not	√				√	
True	False	Not									
√											
	√										
Q29)	$3cm \div 1cm = 3$ $4cm \div 1cm = 4$ $8cm \div 1cm = 8$	$3-2=1$ $4-2=2$ $8-2=6$ $1 \times 2 \times 6 = 12$									
Q30)	$\frac{22}{7} \times 7cm \times 7cm = 154cm^2$ $154cm^2 - 60cm^2 = 94cm^2$										

NAN HUA PRIMARY SCHOOL
Preliminary Examination - 2019
PRIMARY 6 MATHEMATICS

Paper 2

1) $100\% - 40\% - 25\% - 10\% = 25\%$
 $25\% \times 120 = 30$

2) $750 + 2250 = 3000$
 $3000 \div 800 = 3.75$
 $3 + 1 = 4$

3) $35 + 35 - m - 2 - 2 = 66 - m$

4) $\$3.50 + \$3.50 + \$7.20 + \$7.20 = \$21.40$

5) $320 + 320 + 80 + 80 = 800$
 $800 \div 10 = 80$

6) $\$950 \times 80\% = \760
 $\$760 \times 107\% = \813.20

7)

$(5 \times 5) + (4 \times 7) = 53$	$\frac{1}{2} \times 7 \times 9 = 31.5$
$\frac{1}{2} \times 7 \times 9 = 31.5$	$5 \times 2 = 10$
$53 - 31.5 = 21.5 \text{ cm}^2$	$31.5 - 10 = 21.5$

8)

$800 + 2000 = 2800$	$3200 - 2000 = 1200$
$2800 \div 20 = 140 \text{ m/min}$	$4000 - 1200 = 2800$
	$2800 \div 20 = 140 \text{ m/min}$

9) a) $180 - 45 - 90 = 45^\circ$
b) $45 \div 2 = 22.5$
 $180 - 22.5 - 90 = 67.5^\circ$

10)

$$9 \times 3 = 27$$

$$8 \times 2 = 16$$

$$27 - 16 = 11$$

$$55 \div 11 = 5$$

$$5 \times 2 \times 6 = 60$$

$$30 \div 2 = 15$$

$$30 \div 3 = 10$$

$$15 \times 9 = 135$$

$$10 \times 8 = 80$$

$$135 - 80 = 55$$

$$30 + 30 = 60$$

11) a) $\frac{600}{2400} \times 100\% = 25\%$

b) $\frac{5}{16}$

c) $2400 - 600 - 750 = 1050$

Sum of amount spent on rent and transport is 1050. The amount of rent must be between 600 and 750. Both amount must be multiple of 10.

For example: 610 and 440- Refer to back for all possible combination

12) a) $160 - 90 = 70$, June

b) $50 - 30 = 20$

$$\frac{20}{50} \times 100\% = 40\%$$

13) a) $\$11500 - \$3500 = \$8000$

$$\$8000 \div 2 = \$4000$$

b) $\$4000 + \$3500 = \$7500$

$$\$7500 \div 3 = \$2500$$

$$\$4000 - \$2500 = \$1500$$

$$\$1500 \div \$30 = 50$$

$$\$4000 + \$3500 = \$7500$$

$$\$4000 \times 3 = \$12000$$

$$\$12000 - \$7500 = \$4500$$

$$\$4500 \div \$30 = 150$$

$$150 \div 30 = 50$$

$$\$7500 \div 3 = \$2500$$

$$4000 - 2500 = 1500$$

$$1500 \div 30 = 50$$

$$4000 \div 50 = 80$$

$$4000 \div 80 = 50$$

14) a) 25°

b) $25^\circ + 25^\circ = 50^\circ$

$$(180^\circ - 50^\circ) \div 2 = 65^\circ$$

c) 65°

$$90^\circ - 25^\circ = 65^\circ$$

15) Method 1- Using fraction to find $\frac{1}{7}$.

Group A

B	u	30
---	---	----

G	u
---	---

B	u	p	30
---	---	---	----

G	u	p	18
---	---	---	----

Group B

B	p
---	---

G	p	18
---	---	----

$$\frac{1}{7} \rightarrow 30 - 18 = 12$$

$$\frac{4}{7} \rightarrow 12 \times 4 = 48$$

Method 2- Using units and parts/ cross multiplication

Group A

B	G	T
u + 30	u	2u + 30

Group B

B	G	T
p	p + 18	2p + 18
u + 6	u + 24	u + 30

$$2u + 30 = 2p + 18$$

$$u + 6 = p$$

$$\frac{2u+36}{2u+24} = \frac{4}{3}$$

$$6u + 108 = 8u + 96$$

$$2u = 12$$

$$u = 6$$

$$2u + 36 = 48$$

Method 3 – Using total for each group = 2x and cross multiplication

Group A

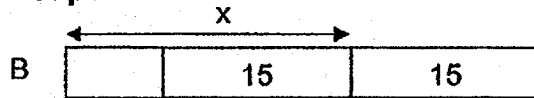

G

Group B

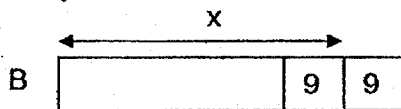

G

Let each group consists of 2x participants

	A	B	Total
Boy	$x + 15$	$x - 9$	$2x + 6$
Girl	$x - 25$	$x + 9$	$2x - 6$
Total	$2x$	$2x$	

Solving for x:

$$\frac{2x-6}{4x} = \frac{3}{7}$$

$$14x - 42 = 12x$$

$$2x = 42$$

$$2x + 6 = 48$$

16) a) $54000 \div 1800 = 30 \text{ cm}$

<p>b) $30 \times 30 = 900$ $1800 + 900 = 2700$ $54000 \div 2700 = 20$ $20 \times 30 \times 30 = 18\ 000$ $18\ 000 \div 3000 = 6 \text{ min}$</p>	<p>$3000 \div 900 = 3\frac{1}{3}$ $3000 \div 1800 = 1\frac{2}{3}$ $3\frac{1}{3} \times 6 = 20$ $1\frac{2}{3} \times 6 = 10$ 6 min</p>
<p>$30 \times 30 = 900$ $1800 \div 900 = 2$ $54 \div 3 = 18$ $18 \div 3 = 6$</p>	

17) a) 9, 12, 21

b) $25 \times 51 = 1275$ or $\frac{1}{2}n^2 + \frac{1}{2}n$

11b)

610	440
620	430
630	420
640	410
650	400
660	390
670	380
680	370
690	360
700	350
710	340
720	330
730	320
740	310



NANYANG PRIMARY SCHOOL

**PRELIMINARY EXAMINATION
2019**

PRIMARY 6

**MATHEMATICS
PAPER 1
(BOOKLET A)**

Total Duration for Booklets A and B: 1 hour

Additional materials: Optical Answer Sheet (OAS)

INSTRUCTIONS TO PUPILS

1. Do not turn over this page until you are told to do so.
2. Follow all instructions carefully.
3. Answer all questions.
4. Shade your answers in the Optical Answer Sheet (OAS) provided.
5. The use of calculators is **NOT** allowed.

Name: _____ ()

Class: Primary 6 ()

Questions 1 to 10 carry 1 mark each. Questions 11 to 15 carry 2 marks each.
For each question, four options are given. One of them is the correct answer.
Make your choice (1, 2, 3 or 4) and shade your answer on the Optical Answer
Sheet. (20 marks)

1 Round 895 547 to the nearest thousand.

- (1) 895 000
- (2) 895 500
- (3) 896 000
- (4) 900 000

2 2 tenths and 6 thousandths is _____

- (1) 0.206
- (2) 2.006
- (3) 20.06
- (4) 200.2

- 3 In the scale below, what is the value of A?

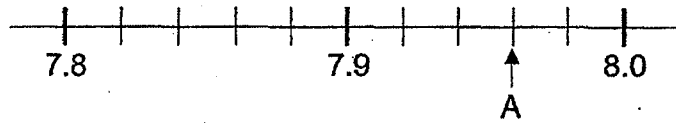

- (1) 8.2
 - (2) 7.96
 - (3) 7.95
 - (4) 7.93
- 4 Which two lines in the square grid are perpendicular to each other?

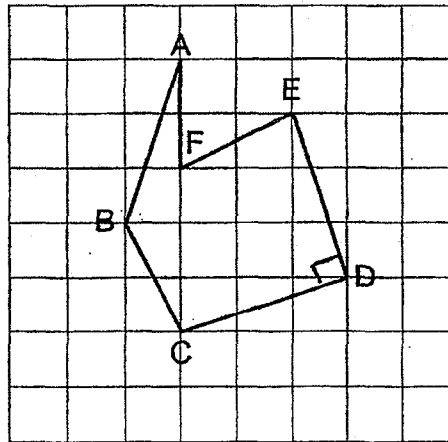

- (1) AB and BC
- (2) BC and CD
- (3) CD and DE
- (4) DE and EF

- 5 In the figure below, AOB, COD and EOF are straight lines. $\angle DOF = 42^\circ$ and $\angle BOE = 73^\circ$. Find $\angle AOC$.

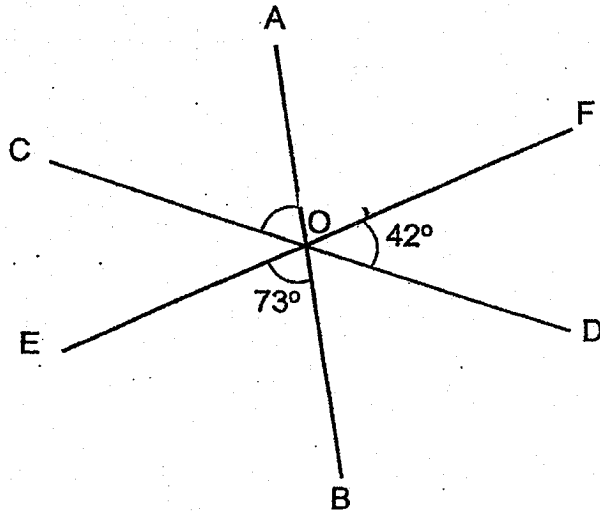

- (1) 42°
- (2) 65°
- (3) 73°
- (4) 115°

6 In the square grid below, which shape is a trapezium?

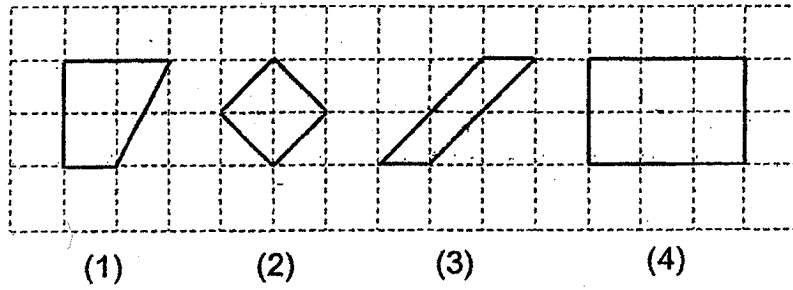

7 The figure below shows a cube.

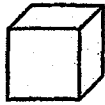

Which of the following is a net of the cube?

(1)



(2)

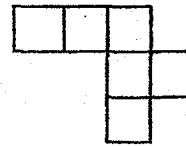

(3)

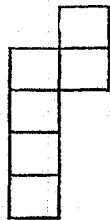

(4)

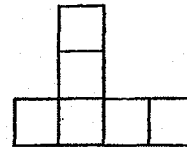

8 Find the value of r such that $4r - r = 24$.

(1) 24

(2) 12

(3) 8

(4) 4

9 The pie chart below shows the volume of water in containers A, B, C, D and E.

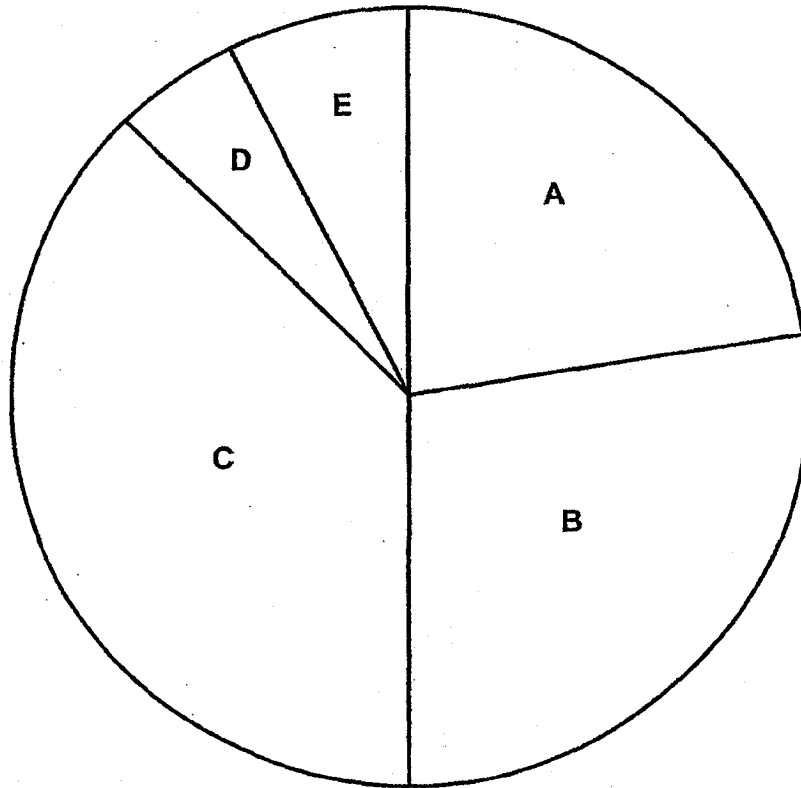

Refer to question and options on the next page.

Which bar graph best represents the information in the pie chart?

(1)

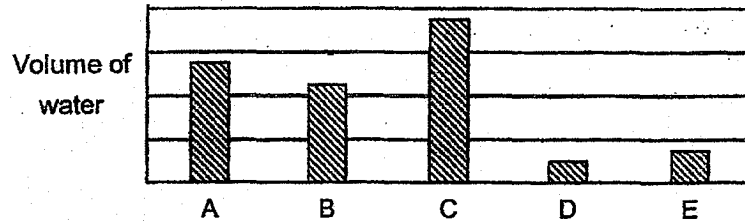

(2)

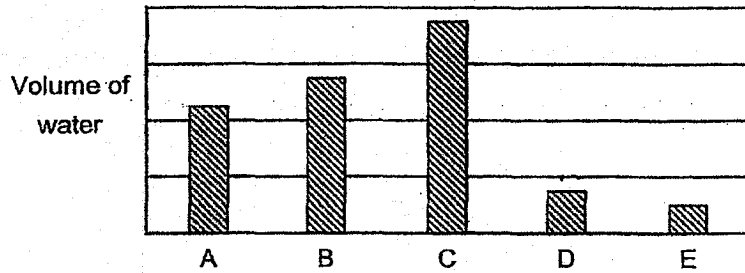

(3)

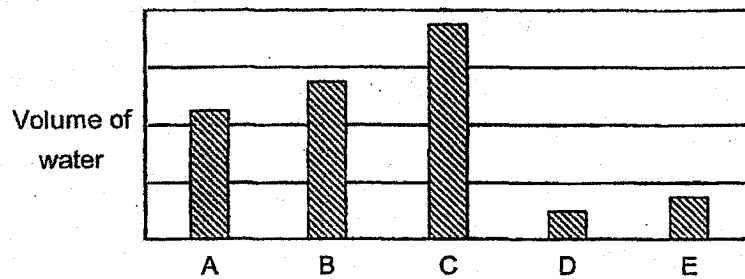

(4)

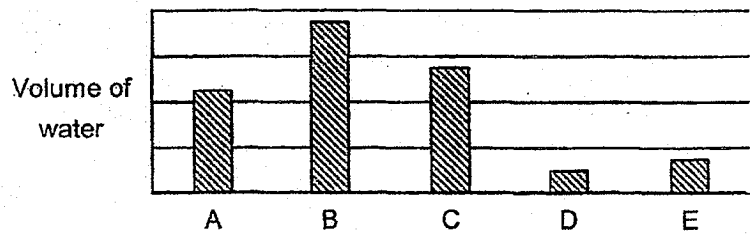

- 10 Which one of the following is likely to be the height of a vending machine in the school canteen?

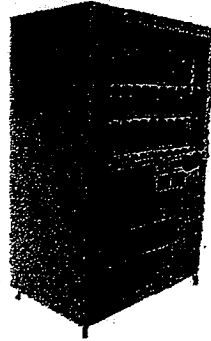

- (1) 20 m
(2) 2 m
(3) 20 cm
(4) 2 cm
- 11 Which one of the following fractions is nearest to 1?

- (1) $\frac{2}{3}$
(2) $\frac{3}{4}$
(3) $\frac{4}{5}$
(4) $\frac{6}{7}$

- 12 The square grid below shows the positions of points P, Q, R, S and T.

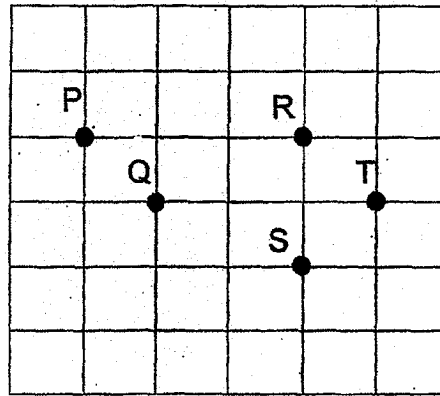

Which of the following statements is true?

- (1) Point S is north of Point R.
- (2) Point T is west of Point Q.
- (3) Point Q is south-east of Point P.
- (4) Point P is north-west of Point S.

- 13 What is the reading shown on the weighing scale below?

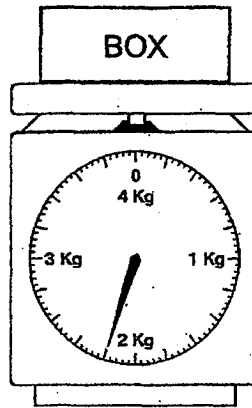

- (1) 2.01 kg
(2) 2.02 kg
(3) 2.1 kg
(4) 2.2 kg
- 14 The height of Ashley is $\frac{2}{3}$ of the height of Zheng Xin. The ratio of the height of Zheng Xin to that of Chloe is 4 : 5. Find the ratio of the height of Chloe to the total height of Zheng Xin and Ashley.
- (1) 3 : 4
(2) 4 : 3
(3) 4 : 15
(4) 15 : 4

15 The first 22 numbers of a number pattern are given below.

2, 2, 0, 1, 4, 2, 2, 2, 0, 1, 4, 2, 2, 2, 0, 1, 4, 2, 2, 2, 0, 1, ...
1st 22nd

Find the sum of the first 48 numbers in the number pattern.

- (1) 85
- (2) 86
- (3) 87
- (4) 88



NANYANG PRIMARY SCHOOL

**PRELIMINARY EXAMINATION
2019**

PRIMARY 6

**MATHEMATICS
PAPER 1
(BOOKLET B)**

Total Duration for Booklets A and B: 1 hour

INSTRUCTIONS TO PUPILS

1. Do not turn over this page until you are told to do so.
2. Follow all instructions carefully.
3. Answer all questions.
4. Write your answers in this booklet.
5. The use of calculators is **NOT** allowed.

Name: _____ ()

Class: Primary 6 ()

Booklet B

/ 25

Any query on marks awarded should be raised by 2 September 2019. We seek your understanding in this matter as any delay in the confirmation of marks will lead to delays in the generation of results.

Questions 16 to 20 carry 1 mark each. Write your answers in the spaces provided. For questions which require units, give your answers in the units stated. (5 marks)

16 Amanda had 2 m of ribbon at first. She used 80 cm of the ribbon. What fraction of the ribbon did she use?

Ans: _____

17 Express 6.04 kilograms in grams.

Ans: _____ g

- 18 The figure is made up of identical squares. Shade two more squares so that the figure has exactly one line of symmetry.

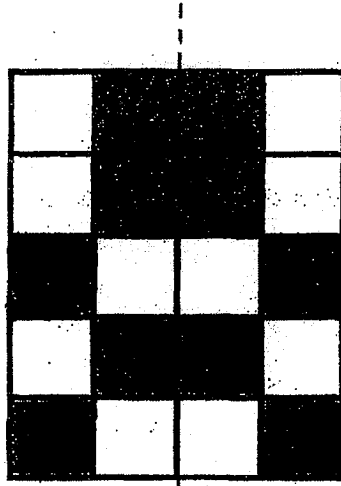

- 19 Johnson stacked 13 unit cubes and glued them together to form the solid below.

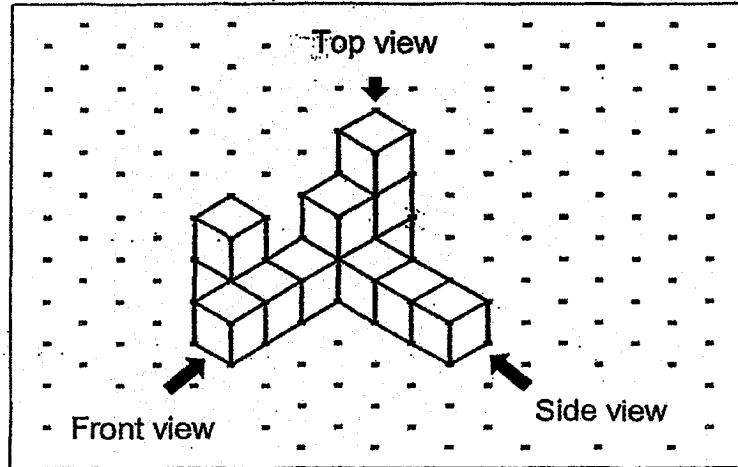

Draw the side view of the solid on the grid below.

Side View

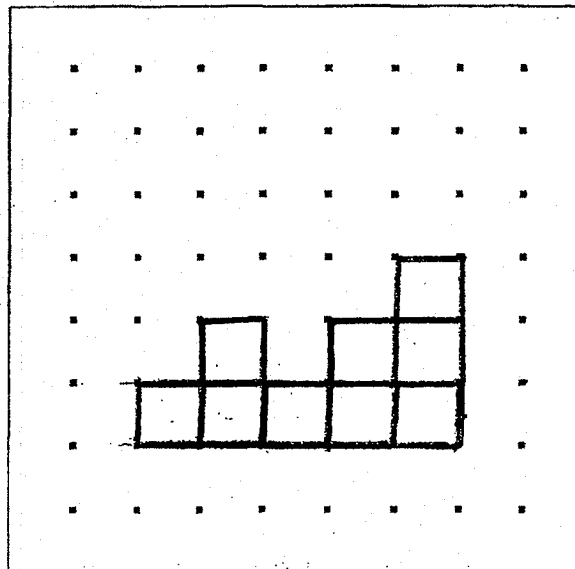

- 20 The solid below is formed by unit cubes. How many unit cubes are there?

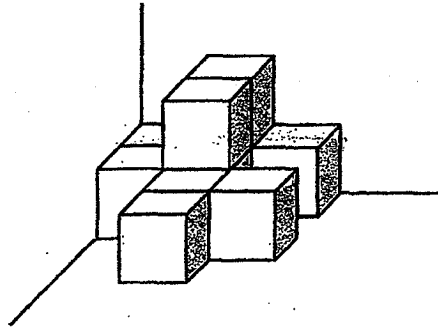

Ans: _____

Questions 21 to 30 carry 2 marks each. Show your working clearly and write your answers in the spaces provided. For questions which require units, give your answers in the units stated. (20 marks)

21 Write down the common multiple of 3 and 5 that is nearest to 27

Ans: _____

22 A wallet costs \$30.40. A belt costs \$16.60 less than the wallet.

- (a) Find the cost of the belt.
- (b) Find the cost of 40 such wallets.

Ans: (a) \$ _____

(b) \$ _____

- 23 The opening hours of a shop are shown below. How long is the shop open each day? Give your answer in hours and minutes.

The Precious Bear Shop
Open Daily
10.30 a.m. to 5.45 p.m.

Ans: _____ h _____ min

- 24 There were 500 people at a food fair on Monday. On Tuesday, there were 400 people at the food fair. What was the percentage decrease in the number of people who went to the food fair from Monday to Tuesday?

Ans: _____ %

- 25 Mrs Tham bought 2780 beads to make some necklaces. She used 9 beads for each necklace. What was the greatest number of such necklaces made by Mrs Tham?

Ans: _____

- 26 Andy has $\frac{1}{2}$ ℓ of oil. He has $\frac{1}{5}$ ℓ less oil than Mei Yan. How much oil does Mei Yan have?

Ans: _____ ℓ

- 27 Mr Chan packs $\frac{3}{4}$ kg of curry powder into small packets. Each small packet contains $\frac{1}{8}$ kg of curry powder. How many small packets of curry powder are there?

Ans: _____

- 28 In the figure below, WXY and WZY are isosceles triangles. $WX = YX$ and $WZ = YZ$. $\angle WXY = 70^\circ$ and $\angle YWZ = 35^\circ$. Find $\angle XYZ$.

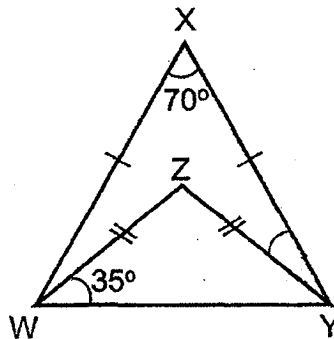

Ans: _____^o

- 29 In the figure below, STUV is a parallelogram.
 $\angle STU = 107^\circ$ and $\angle TSW = 53^\circ$. Find $\angle VSW$.

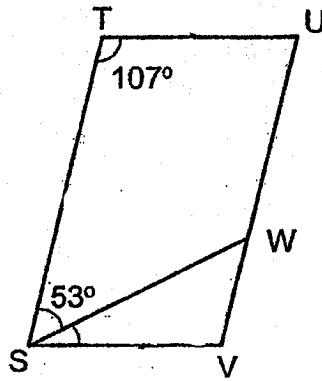

Ans: _____^o

- 30 The length and breadth of a rectangle are $3y$ metres and $(y + 1)$ metres respectively. Find its perimeter given that $y = 5$.

Ans: _____ m

End of Paper

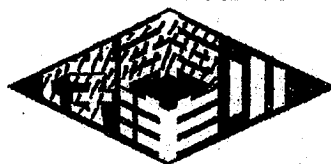

NANYANG PRIMARY SCHOOL

**PRELIMINARY EXAMINATION
2019**

PRIMARY 6

**MATHEMATICS
PAPER 2**

Duration: 1 hour 30 minutes

INSTRUCTIONS TO PUPILS

1. Do not turn over this page until you are told to do so.
2. Follow all instructions carefully.
3. Answer all questions.
4. Write your answers in this booklet.
5. The use of an approved calculator is expected, where appropriate.

Name: _____ ()

Class: Primary 6 ()

Parent's Signature: _____

Booklet A	/ 20
Booklet B	/ 25
Paper 2	/ 55
Total	/ 100

Any query on marks awarded should be raised by 2 September 2019. We seek your understanding in this matter as any delay in the confirmation of marks will lead to delays in the generation of results.

Questions 1 to 5 carry 2 marks each. Show your working clearly and write your answers in the spaces provided. For questions which require units, give your answers in the units stated. (10 marks)

- 1 Adele has n albums. Benjamin has $5n$ albums. Adele has 8 fewer albums than Benjamin. How many albums does Adele have?

Ans: _____

- 2 Tap A takes 36 minutes to fill a tank completely. Tap B takes 72 minutes to fill the same tank completely. How many minutes will Tap A and Tap B take to fill the tank completely when they are turned on at the same time?

Ans: _____ min

- 3 The average number of books that Ada, Baba and Cindy have is 17. Cindy has 21 books. Baba has more books than Ada. At most, how many books does Ada have?

Ans: _____

- 4 Susan deposits \$50 000 in a bank for one year. The interest rate is 1.8% per year. How much will she have in the bank at the end of one year?

Ans: \$ _____

- 5 In the figure below, PQRS is a trapezium. TUQ and TSR are straight lines. $PQ \parallel SR$. $\angle PUQ = 80^\circ$ and $\angle QPU = 76^\circ$. Find $\angle STU$.

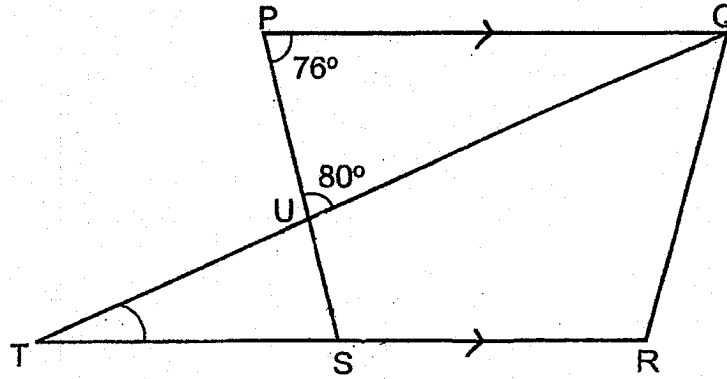

Ans: _____ °

For questions 6 to 17, show your working clearly and write your answers in the spaces provided. The number of marks available is shown in brackets [] at the end of each question or part-question. (45 marks)

- 6 Mdm Ler has 4 boxes of fruits, Box A, Box B, Box C and Box D. The bar graph below shows the number of fruits in each box. The bar representing Box D has not been drawn.

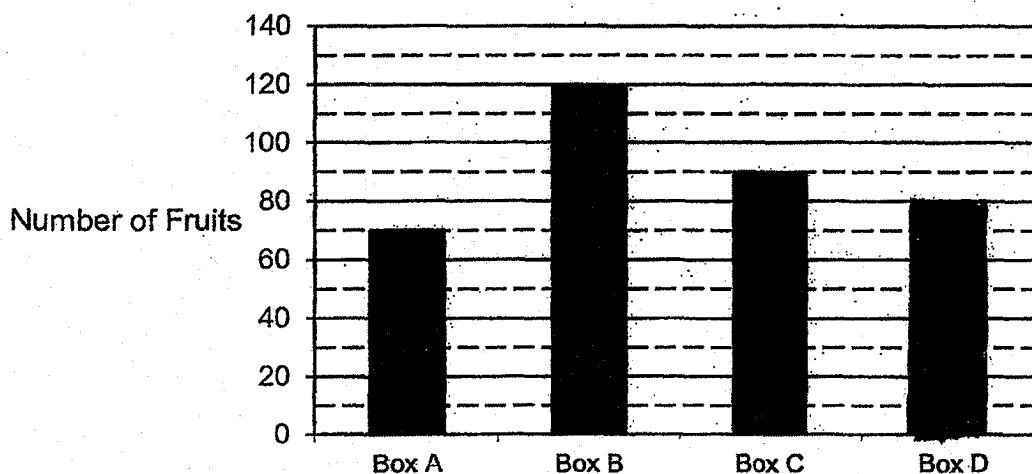

- (a) How many more fruits are there in Box C than Box A?
- (b) Box B contains only pears and oranges. There are 4 more pears than oranges in Box B. How many oranges are there in Box B?
- (c) The total number of fruits in the 4 boxes is 360. Find the number of fruits in Box D.

Ans: (a) _____ [1]
(b) _____ [2]
(c) _____ [1]

- 7 In the figure below, BDEF is a rhombus. ACE is a triangle.
 $\angle ABF = 76^\circ$ and $\angle DBC = 29^\circ$.

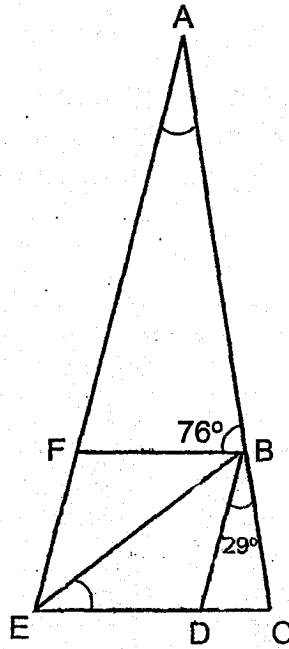

- (a) Find $\angle BED$.
(b) Find $\angle EAC$.

Ans: (a) _____ [2]

(b) _____ [2]

- 8 The figure below shows a large circle and two identical small semicircles. The diameter of the large circle, POQ, is 24 cm.

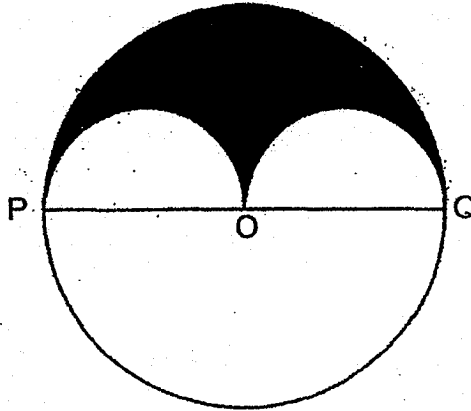

- (a) Find the perimeter of the shaded part.
Take $\pi = 3.14$
- (b) Find the total area of the unshaded parts.
Take $\pi = 3.14$.

Ans: (a) _____ [2]

(b) _____ [3]

9 In the square grid below, AB and BC form two sides of a parallelogram ABCD. Each side is drawn by joining dots on the square grid with a straight line. In the same way,

(a) complete the drawing of parallelogram ABCD. [1]

(b) Using the given line BC, complete the drawing of square BCEF such that it does not overlap parallelogram ABCD. [2]

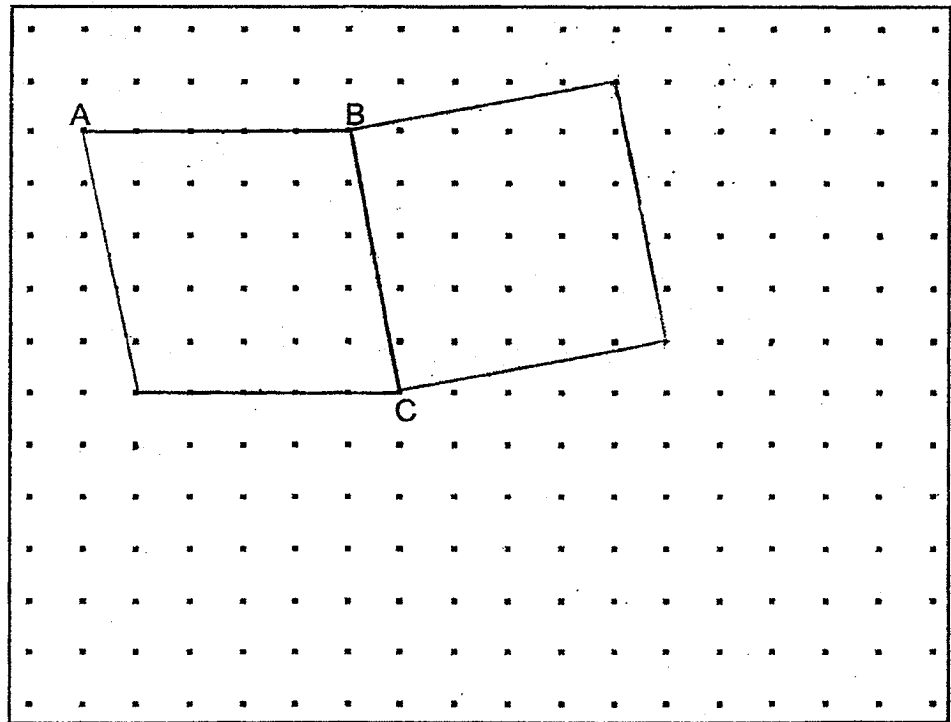

- 10 At a sports shop, each basketball cost \$23.60 and each football cost \$36.40. Mr Chong bought 3 times as many basketballs as footballs. He spent \$550.40 more on the basketballs than the footballs. How many footballs did Mr Chong buy?

Ans: _____ [3]

- 11 There are some children in a hall. $\frac{5}{9}$ of them are boys. The girls are divided equally into 11 groups. The total number of girls is fewer than 60. There are 6 boys who wear spectacles. How many boys do not wear spectacles?

Ans: _____ [3]

- 12 Da Ren has 10 candies. Elijah has 30 candies. Faith has 4 fewer candies than the average number of candies that Da Ren, Elijah and Faith have. How many candies do they have altogether?

Ans: _____ [3]

- 13 At 7 a.m., Cyclist A left Town M for Town N. At 8 a.m., Cyclist B left Town M for Town N. Cyclist A travelled at a constant speed of 15 km/h and Cyclist B travelled at a constant speed of 10 km/h. Both cyclists did not change their speeds throughout. After arriving at Town N, Cyclist A immediately left Town N for Town M. Cyclist A and Cyclist B passed each other at 11 a.m. At what time did Cyclist B arrive at Town N?

Ans: _____ [3]

- 14 In the figure below, X and Y are identical rectangular tanks. X has a square base of side 16 cm and a height of 64 cm.

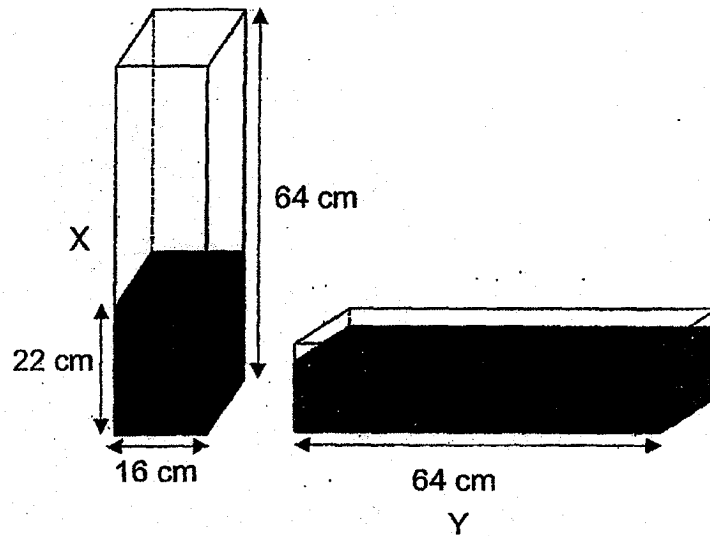

At first, X was completely filled with water and Y was empty. John poured the water from X to Y, without spilling, until the height of the water level in X became 22 cm.

- (a) How much water was there in Y in the end?
(b) Find the height of water in Y in the end.

Ans: (a) _____ [2]

(b) _____ [2]

- 15 The figure below shows a grey cube and a white cube. The length of each edge of the grey cube is twice that of the white cube. Xin Neng wants to use 5 grey cubes and the least number of white cubes to build a new cube.

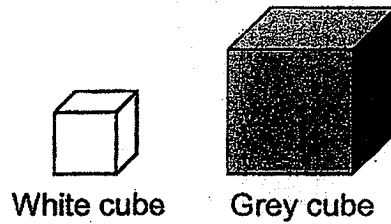

- (a) How many white cubes does Xin Neng need to build the new cube?
- (b) Given that the volume of the new cube is 1728 cm^3 , find the length of the edge of the white cube.

Ans: (a) _____ [2]

(b) _____ [2]

- 16 The table below shows the number of pens in each type of bag.

Type of bag	Number of pens per bag
Red	40
Blue	50
Green	60

- (a) Mdm Ng has a total of 8 red and green bags. Find the smallest possible difference between the total number of pens in Mdm Ng's red bags and the total number of pens in her green bags.
- (b) Mr Lee has some red and some blue bags. The ratio of the total number of pens in Mr Lee's red bags to the total number of pens in his blue bags is 6 : 5. Express the number of his blue bags as a fraction of the total number of his bags.

Ans: (a) _____ [2]

(b) _____ [2]

17 Joong Ki, Minho and Ali have some green and some red buttons. Joong Ki has 9 more buttons than Minho. Minho has 5 more green buttons than Joong Ki. The ratio of the number of red buttons that Joong Ki has to the number of red buttons that Minho has is 5 : 3. The ratio of the number of green buttons to red buttons Ali has is 3 : 1.

- (a) How many red buttons do Joong Ki and Minho have altogether?
- (b) Each statement below is either true, false or not possible to tell from the information given. For each statement, put a tick (✓) to indicate your answer.

	True	False	Not possible to tell
Ali has 11 more green buttons than red buttons.			
The total number of buttons that Joong Ki, Minho and Ali have is an odd number.			

[2]

Ans: (a) _____ [3]

End of Paper

SCHOOL : NANYANG PRIMARY SCHOOL
 LEVEL : PRIMARY 6
 SUBJECT : MATH
 TERM : 2019 PRELIM

PAPER 1 BOOKLET A

Q 1	Q2	Q3	Q4	Q5	Q6	Q7	Q8	Q9	Q10
3	1	2	3	2	1	1	3	3	2

Q 11	Q12	Q13	Q14	Q15
4	3	4	1	4

PAPER 1 BOOKLET B

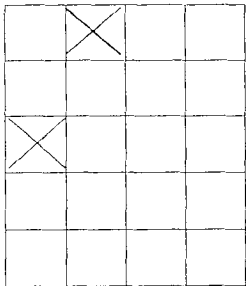
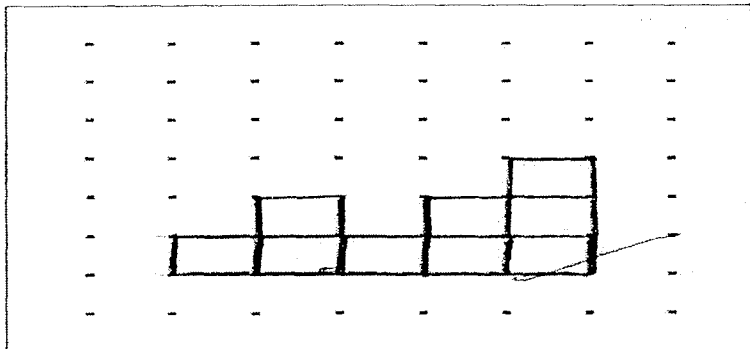
Q16)	$2m = 200cm$ $\frac{80}{200} = \frac{2}{5}$
Q17)	$6.04kg = 6040g$
Q18)	
Q19)	<p style="text-align: center;">Side View</p> 

Q20)	10
Q21)	30
Q22)	a) \$30.40 - \$16.60 = \$13.80 b) \$30.40 x 40 = \$1216
Q23)	7h 15min
Q24)	500 - 400 = 100 $\frac{100}{500} \times 100 = 20\%$
Q25)	2790 ÷ 9 = 308
Q26)	$\frac{1}{2} + \frac{1}{5} = \frac{5}{10} + \frac{2}{10} = \frac{7}{10} l$
Q27)	$\frac{3}{4} = \frac{24}{32}$ $\frac{1}{8} = \frac{4}{32}$ 24 ÷ 4 = 6
Q28)	∠ZWY = ∠ZYW 180° - 70° = 110° 110° ÷ 2 = 55° 55° - 35° = 20°
Q29)	180° - (107° + 53°) = 20°
Q30)	5 × 3 = 15 5 + 1 = 6 6 × 2 = 12 15 × 2 = 30 30 + 12 = 42m

PAPER 2

Q1)	A : B 1 : 5 5 - 1 = 4 8 ÷ 4 = 2						
Q2)	<table style="width: 100%; border: none;"> <tr> <td style="text-align: center; width: 50%;">A</td> <td style="text-align: center; width: 50%;">B</td> </tr> <tr> <td>36min → tank</td> <td>72min → tank</td> </tr> <tr> <td>1min → $\frac{1}{36}$ tank</td> <td>1min → $\frac{1}{72}$ tank</td> </tr> </table> In 1min → A+B = $\frac{1}{36} + \frac{1}{72} = \frac{2}{72} + \frac{1}{72} = \frac{3}{72}$ = 72 ÷ 3 = 24 min	A	B	36min → tank	72min → tank	1min → $\frac{1}{36}$ tank	1min → $\frac{1}{72}$ tank
A	B						
36min → tank	72min → tank						
1min → $\frac{1}{36}$ tank	1min → $\frac{1}{72}$ tank						

Q3)	$17 \times 3 = 51$ $51 - 21 = 30$ $30 \div 2 = 15$ $15 - 1 = 14$
Q4)	$\frac{101.8}{100} \times \$50000 = \$50900$
Q5)	$\angle PSR = 180^\circ - 76^\circ = 104^\circ$ $\angle QUS = 180^\circ - 80^\circ = 100^\circ$ $\angle STU = 180^\circ - 80^\circ - 76^\circ = 24^\circ$
Q6)	a) $90 - 70 = 20$ fruits b) $120 - 4 = 116$ $116 \div 2 = 58$ oranges c) $70 + 90 + 120 = 280$ $360 - 280 = 80$ fruits
Q7)	a) $180^\circ - (76^\circ + 29^\circ) = 75^\circ$ $75^\circ \div 2 = 37.5^\circ$ b) $37.5^\circ \times 2 = 75^\circ$ $180^\circ - 75^\circ = 105^\circ$ $180^\circ - 105^\circ = 75^\circ$ $180^\circ - 75^\circ - 76^\circ = 29^\circ$
Q8)	a) $24 \times 3.14 \times \frac{1}{2} = 37.68$ $24 \div 2 = 12$ $12 \times 3.14 = 37.68$ $37.68 + 37.68 = 75.36$ cm b) $12 \times 12 \times 3.14 \times \frac{1}{2} = 226.08$ $12 \div 2 = 6$ $6 \times 6 \times 3.14 = 113.04$ $113.04 + 226.08 = 339.12 \text{cm}^2$
Q9)	

Q10)	$\$23.60 \times 3 = \70.80 $\$70.80 - \$36.40 = \$34.40$ $\$550.40 \div \$34.40 = 16 \text{ footballs}$									
Q11)	$44 \div 4 = 11$ $11 \times 5 = 55$ $55 - 6 = 49 \text{ boys}$									
Q12)	$30 - 4 = 26$ $26 + 10 = 36$ $36 \div 2 = 18$ $18 \times 3 = 54$									
Q13)	$10 \times 3 = 30$ $15 \times 4 = 60$ $60 + 30 = 90$ $90 \div 2 = 45$ $45 \div 10 = 4\frac{1}{2} \text{ h}$ <div style="text-align: center;">  <p>8a.m. 4h 12p.m. 1/2 h 12.30p.m.</p> </div> <p style="text-align: center;">ANS: 12.30p.m.</p>									
Q14)	a) $64 - 22 = 42$ $42 \times 16 \times 16 = 10752$ $10752 \text{cm}^3 \rightarrow 10.752$ b) $10752 \div 64 \div 16 = 10.5 \text{cm}$									
Q15)	a) $2 \times 2 \times 2 = 8$ $8 \times 3 = 24 \text{ cubes}$ b) $\sqrt[3]{1728} = 12$ $12 \div 2 = 6$ $6 \div 2 = 3 \text{cm}$									
Q16)	a) $40 \times 5 = 200$ $60 \times 3 = 180$ $200 = 180 = 20$ <div style="float: right;"> b) R : B $(6 \times 20) : (5 \times 20)$ $120 \div 40 = 3$ $100 \div 50 = 2$ $\frac{2}{3+2} = \frac{2}{5}$ </div>									
Q17)	a) $9 + 5 = 14$ $5 - 3 = 2$ $14 \div 2 = 7$ $7 \times 8 = 56 \text{ red buttons}$ b) <table border="1" style="margin-left: auto; margin-right: auto;"> <thead> <tr> <th>True</th> <th>False</th> <th>Not</th> </tr> </thead> <tbody> <tr> <td></td> <td style="text-align: center;">√</td> <td></td> </tr> <tr> <td style="text-align: center;">√</td> <td></td> <td></td> </tr> </tbody> </table>	True	False	Not		√		√		
True	False	Not								
	√									
√										



**RAFFLES GIRLS' PRIMARY SCHOOL
PRELIMINARY EXAMINATION
MATHEMATICS (PAPER 1)
PRIMARY 6**

Name: _____ ()

Form Class: P6 _____

Math Teacher : _____

Date: 21 Aug 2019

Duration: 1 hour

Your Paper 1 Score (Out of 45 marks)	
Your Paper 2 Score (Out of 55 marks)	
Your Total Score (Out of 100 marks)	
Parent's Signature	

INSTRUCTIONS TO CANDIDATES

1. Do not turn over this page until you are told to do so.
2. Follow all instructions carefully.
3. Answer **ALL** questions and show all working clearly.
4. **NO** calculator is allowed for this paper.

Questions 1 to 10 carry 1 mark each. Questions 11 to 15 carry 2 marks each.
For each question, four options are given. One of them is the correct answer.
Make your choice (1, 2, 3 or 4). Shade your answer (1, 2, 3 or 4) on the OAS provided.
All diagrams are not drawn to scale. (20 marks)

1.

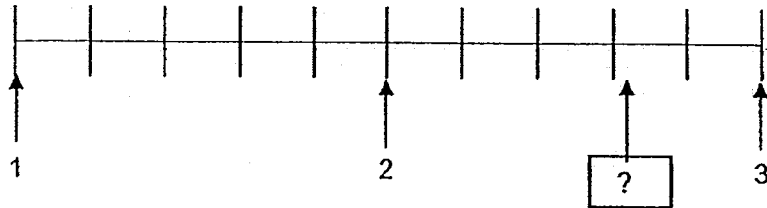

What is a possible number in the box?

- (1) 2.35
- (2) 2.55
- (3) 2.63
- (4) 2.75

2. What is the length of the spoon?

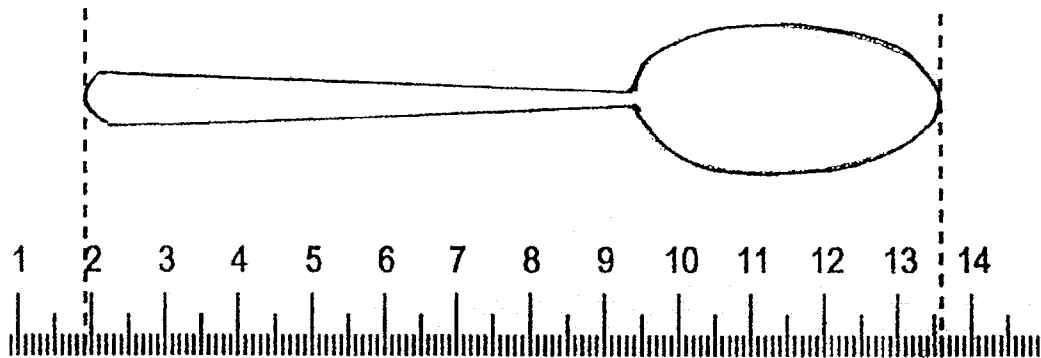

- (1) 1.9 cm
- (2) 11.7 cm
- (3) 12.7 cm
- (4) 13.6 cm

3. Which digit in 107 438 is in the ten thousands place?

(1) 1

(2) 0

(3) 3

(4) 4

4. Round 10 989 to the nearest hundred.

(1) 10 900

(2) 10 990

(3) 11 000

(4) 11 090

5. Alex, Ben, Carl and Den shared a cake. Alex ate $\frac{1}{5}$ of the cake. Ben ate $\frac{3}{10}$ of the cake. Carl ate $\frac{1}{3}$ of the cake while Dan ate the remaining cake. Who ate the largest portion of the cake?

(1) Alex

(2) Ben

(3) Carl

(4) Dan

6. Find the area of the shaded triangle.

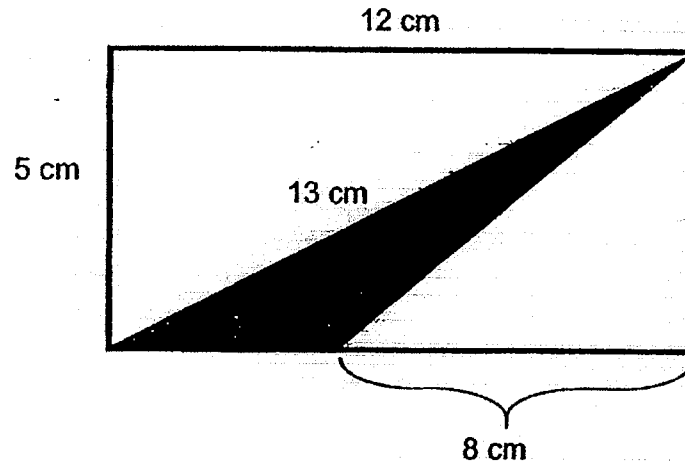

- (1) 10 cm^2
- (2) 20 cm^2
- (3) 30 cm^2
- (4) 32.5 cm^2
7. Mary and Sally had an equal number of stamps. Mary gave $\frac{3}{7}$ of her stamps to Sally. What was the ratio of Sally's number of stamps to Mary's number of stamps in the end?
- (1) 10 : 7
- (2) 10 : 3
- (3) 7 : 3
- (4) 5 : 2

8. The solid has 4 triangular faces.

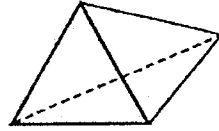

Which of the following nets can be folded to form this solid?

(A)

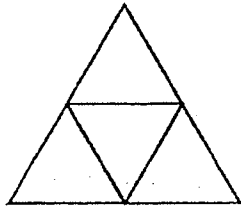

(B)

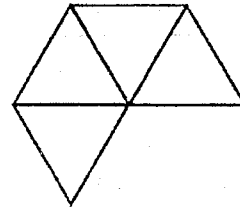

(C)

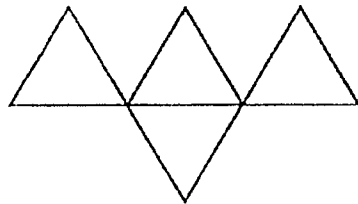

(D)

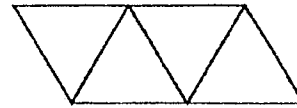

- (1) A and B only
(2) B and C only
(3) A and D only
(4) B and D only

9. The table shows the number of toys produced at a factory from Monday to Saturday.

Day	Number of toys produced
Monday to Friday	$3k$ per day
Saturday	$4k - 5$

What was the total number of toys produced from Monday to Saturday?
Express your answer in terms of k in the simplest form.

- (1) $7k - 5$
- (2) $15k$
- (3) $19k$
- (4) $19k - 5$

- 10.

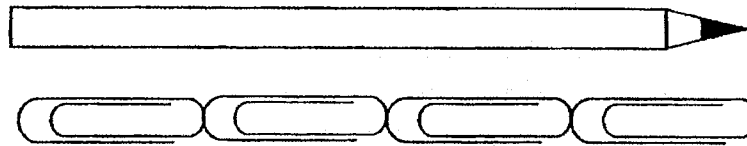

The length of 1 paper clip is 0.018 m. What is the length of the pencil?

- (1) 0.072 cm
- (2) 0.72 cm
- (3) 7.2 cm
- (4) 72 cm

11. In the figure, AOB and COD are straight lines. $\angle COB = 135^\circ$ and $\angle EOD = 75^\circ$. Find $\angle EOB$.

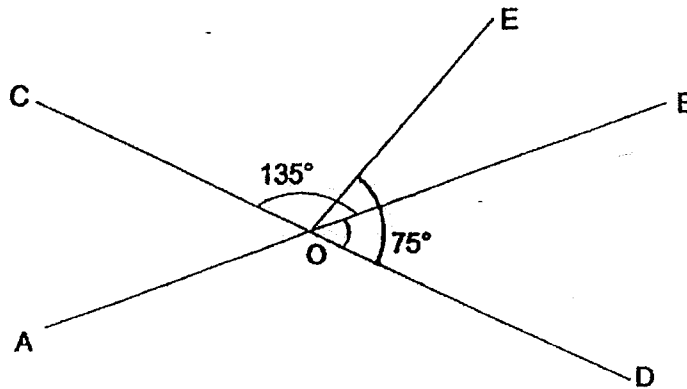

- (1) 30°
(2) 45°
(3) 90°
(4) 105°
12. What is the total volume when the 6-cm metal cube is placed in the container?

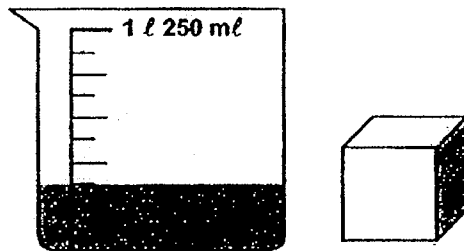

- (1) 216 cm^3
(2) 375 cm^3
(3) 516 cm^3
(4) 591 cm^3

13. 30% of Tom's savings is equal to 25% of Mary's savings. What percentage of Tom's savings is Mary's savings?

(1) $33\frac{1}{3}\%$

(2) $83\frac{1}{3}\%$

(3) 120%

(4) 300%

14. The table shows the exchange rate for Singapore dollar and US dollar.

1 Singapore dollar (SGD) = 0.70 US dollar (USD)

How many Singapore dollars will I need to exchange for 1400 US dollar?

(1) 700 SGD

(2) 980 SGD

(3) 1400.30 SGD

(4) 2000 SGD

15. A box can fit exactly 8 large cubes, 64 medium cubes, or 512 small cubes. 3 large cubes, 32 medium cubes and some small cubes are put into such a box. What is the greatest possible number of small cubes that can fit into the box?

(1) 64

(2) 128

(3) 192

(4) 256

Questions 16 to 20 carry 1 mark each. Write your answers in the spaces provided.
For questions which require units, give your answers in the units stated. All diagrams
are not drawn to scale. (5 marks)

16. What is the answer in the box?

$$10\frac{5}{7} = \frac{56}{7} + \boxed{}$$

Leave your answer as an improper fraction.

Ans: _____

17. Evaluate $48 \times (8 - 4 \times 2)$.

Ans: _____

18. When it is 10 a.m. in Singapore, it is 4 a.m. in South Africa on the same day. What time would it be in Singapore when it is 11.30 a.m. in South Africa? Give your time in 24-hour clock.

Ans: _____

19. A number is 0.50 when rounded to the nearest hundredth. What is the smallest possible number?

Ans: _____

20. Find the value when 1.099 is subtracted from 3.

Ans: _____

Questions 21 to 30 carry 2 marks each. Show your working clearly in the space provided for each question and write your answers in the spaces provided. For questions which require units, give your answers in the units stated. All diagrams are not drawn to scale. (20 marks)

21. What is the answer in the box?

$$24 \times 189 = 24 \times 140 + 24 \times \boxed{}$$

Ans: _____

22. A painter has 2 ℓ of red paint. He used $\frac{1}{5}$ of it to mix with $\frac{2}{3}$ ℓ of blue paint to get some purple paint. How much purple paint did he get?

Ans: _____ ℓ

23. Mr Tan deposited \$4000 in a fixed deposit account at ABC Bank at an interest rate of 1.5% per year. What was the amount of the interest earned in one year?

Ans: \$ _____

24. Muthu had $9p$ sweets. He gave 5 sweets to each of his three friends and packed the remaining sweets equally into 3 packets. How many sweets were there in each packet? Give your answer in terms of p in the simplest form.

Ans: _____

25. Randy has 4 boxes of marbles. The number of marbles in each of the boxes is shown in the table.

Box	Number
A	27
B	19
C	25
D	26

Which box should he remove so that the average number of the marbles in the remaining boxes is 24?

Ans: Box _____

26. Find the perimeter of the figure.

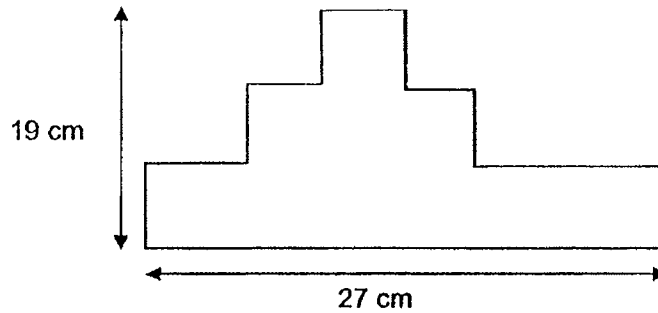

Ans: _____ cm

27. In a 4 by 100 m relay, Rani completed the first 100 m in 10 s, Eunice completed the second 100 m in 15 s, Joyce completed the third 100 m in 13 s and Siti completed the last 100 m in 12 s. What was the average speed of the 4 children for the relay?

Ans: _____ m/s

28. A group of children was asked to name their favourite flavour of ice-cream. The pie chart shows their preference.

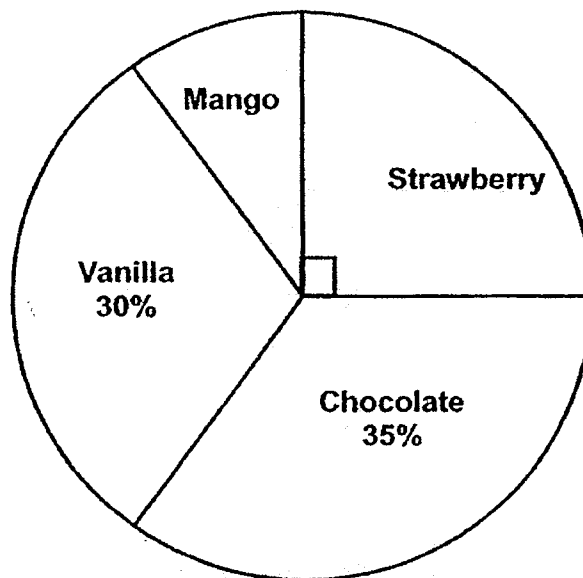

The number of children who liked chocolate and strawberry ice-cream was 42 more than the number of children who liked vanilla ice-cream. How many children liked mango ice-cream?

Ans: _____

29. In the figure, ABC is an isosceles triangle with $BC = BA$. BE is a straight line. $\angle DCE = 117^\circ$. Find $\angle ABD$.

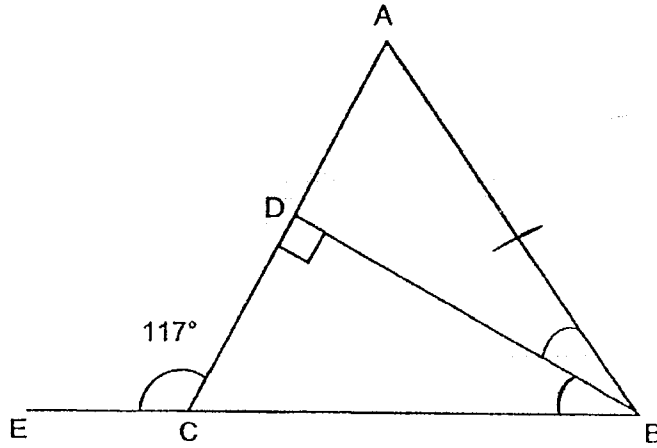

Ans: _____°

30. The number of stickers Kevin had was $\frac{1}{4}$ more than the number of stickers John had. After Kevin gave 96 stickers to John, John had twice as many stickers as Kevin. How many stickers did John have at the end?

Ans: _____

End of Paper



**RAFFLES GIRLS' PRIMARY SCHOOL
PRELIMINARY EXAMINATION
MATHEMATICS (PAPER 2)
PRIMARY 6**

Name: _____ ()

Form class: P6 _____

Math Teacher : _____

Date: 21 Aug 2019

Duration: 1 h 30 min

INSTRUCTIONS TO CANDIDATES

1. Do not turn over this page until you are told to do so.
2. Follow all instructions carefully.
3. Answer **ALL** questions and show all working clearly.
4. The use of calculator is allowed for this paper.

Questions 1 to 5 carry 2 marks each. Show your working clearly in the space provided for each question and write your answers in the spaces provided.
 For questions which require units, give your answers in the units stated.
 All diagrams are not drawn to scale. (10 marks)

1. John had a collection of local and foreign stamps. The ratio of the number of local stamps to the number of foreign stamps he had at first was 7 : 3. After giving away 48 foreign stamps, the ratio of the number of local stamps to the number of foreign stamps became 5 : 2. How many foreign stamps did John have in the end?

Ans : _____

2. In the figure, ABC is an isosceles triangle with $AC = AB$, $\angle ABD = 34^\circ$. $AD = AE$ with $\angle ADE = 48^\circ$. Find $\angle CAD$.

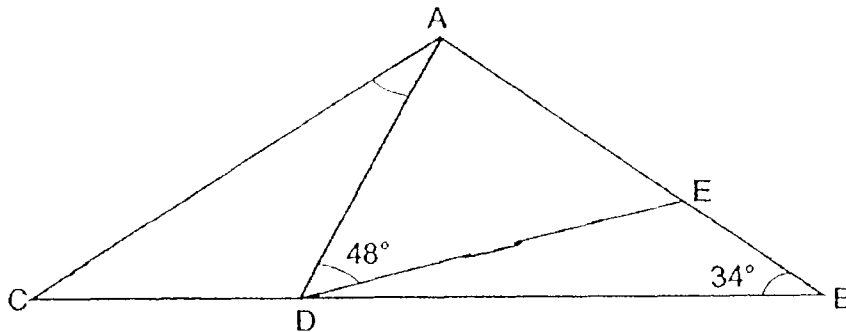

Ans: _____°

3. A survey was conducted on the number of children in each household within a block of flats. The pie chart shows the results of the survey. AB is a straight line.

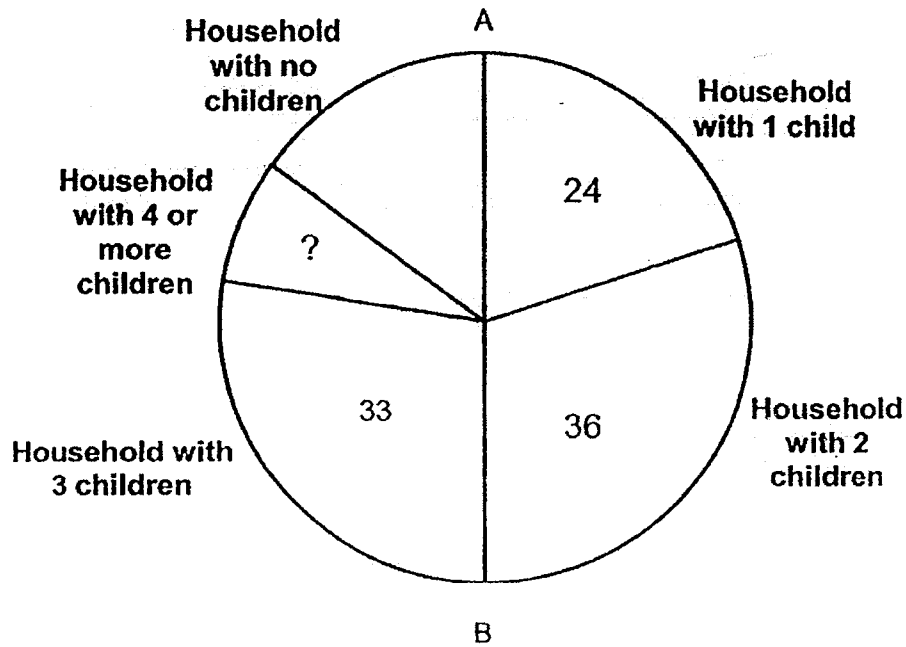

The number of household with 2 children was twice the number of household with no children. Express the number of household with 4 or more children as a fraction of the total number of household. Give your answer in the simplest form.

Ans : _____

4. Terence had a length of wire. He used the wire to make the triangle as shown.

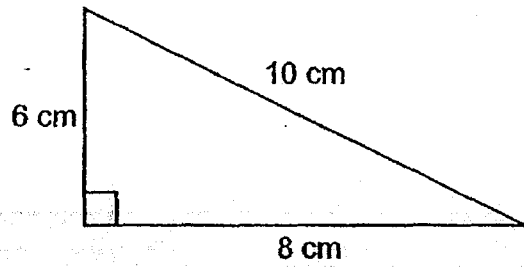

With the same wire, he used the entire length to make a square. What was the percentage increase in the area of the square compared to the area of triangle?

Ans : _____ %

5. The figure below is a triangle with sides A, B and C.

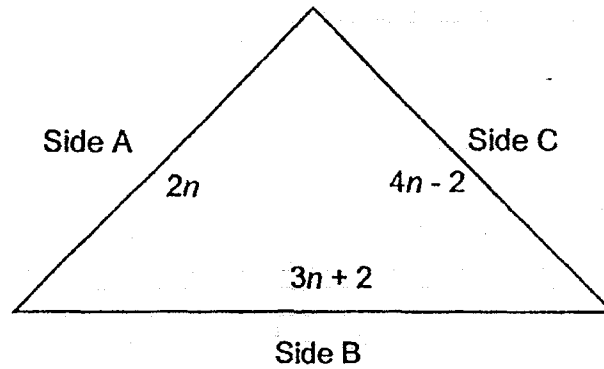

Each of the statements below is either true, false or not possible to tell from the information given. For each statement, put a tick(✓) to indicate your answer.

Statement	True	False	Not possible to tell
a) The length of side B is longer than the length of side A.			
b) The figure is an isosceles triangle as length of side A is equal to length of side C.			
c) The perimeter of the triangle is $(9n + 4)$ unit.			

For questions 6 to 17, show your working clearly in the space provided for each question and write your answers in the spaces provided. The number of marks available is shown in the brackets [] at the end of each question or part-question. All diagrams are not drawn to scale. (45 marks)

6.

$$\begin{array}{ccccccc} \triangle & + & \triangle & + & \triangle & + & \square = 81.76 \\ \square & + & \square & + & \triangle & & = 38.56 \end{array}$$

Find the value of \square

Ans : _____ [3]

7. Ella and May had \$358 altogether. Ella and Kevin had \$698 altogether. Kevin had 5 times as much money as May. How much did Ella have at first?

Ans : _____ [3]

8. In the figure, ABCD is a square and EFGC is a trapezium. $CE = BE$, $\angle EFG = 110^\circ$ and $\angle DCG = 230^\circ$.

(a) Find $\angle FGC$.

(b) Find $\angle CBE$.

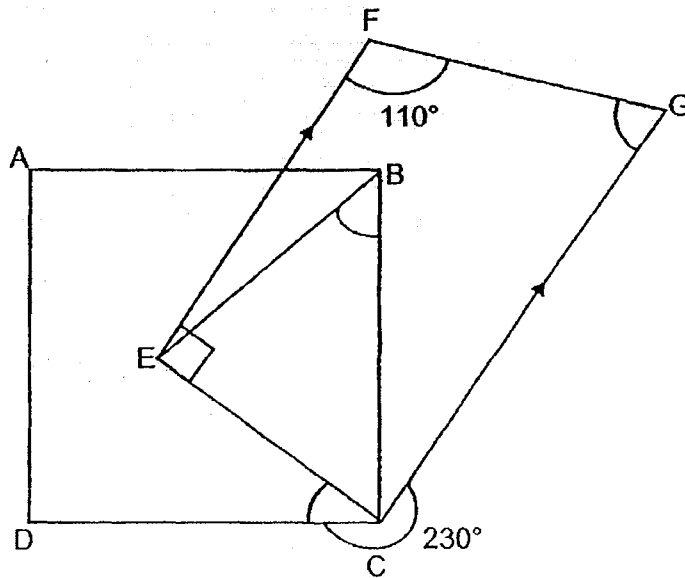

Ans: (a) _____ [1]

(b) _____ [2]

9. The figure is made up of a circle and three equilateral triangles of side 18 cm. Find the perimeter of the shaded parts. Take $\pi = 3.14$.

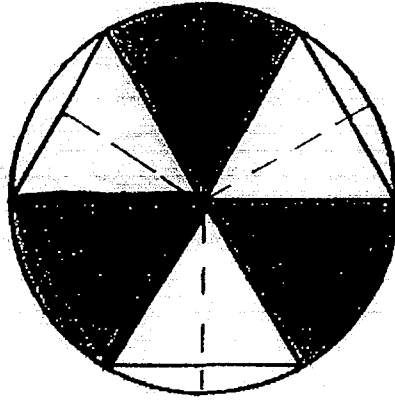

Ans : _____ [3]

10. Valerie had 40% more books than Isabelle. After Valerie bought some books, her number of books increased by 25%. Isabelle gave away 25% of her books. In the end, both the girls had 750 books altogether. How many books did Valerie have at first?

Ans : _____ [3]

11. The bar graph shows the sales of four food items at a fun fair.



The table shows the prices of the food items.

Type of food items	Price per item
Burger	\$5
Hot dog	\$3
Chicken pie	\$4
Waffles	\$3

- (a) The quantity for two of the food items sold was the same. Which were the two food items?
- (b) What percentage of the food items sold were burgers?
Leave your answer to the nearest 1 decimal place.

Ans: (a) _____ and _____ [2]

(b) _____ [2]

12. The table shows the charges for electricity consumption by ABC company.

Usage in kilowatts (kW)	Charges per kW
First 50 kW	\$0.55
Next 100 kW	\$0.72
Every additional kW and thereafter	\$0.88

- (a) Mrs Tan's family used 50 kW of electricity in July. How much did her family pay for their electricity consumption?
- (b) Mr Lee spent \$129.42 on electricity consumption in August. How many kilowatts of electricity did his family consume?

Ans: a) _____ [1]

b) _____ [3]

13. In the figure, ABC and BDC are triangles and BECF is a parallelogram. FH is a straight line, $\angle GCH = 198^\circ$. $\angle BEC = 104^\circ$, $\angle BAC = 50^\circ$ and $\angle ABE = 25^\circ$.

(a) Find $\angle DGB$.

(b) Find $\angle ACE$.

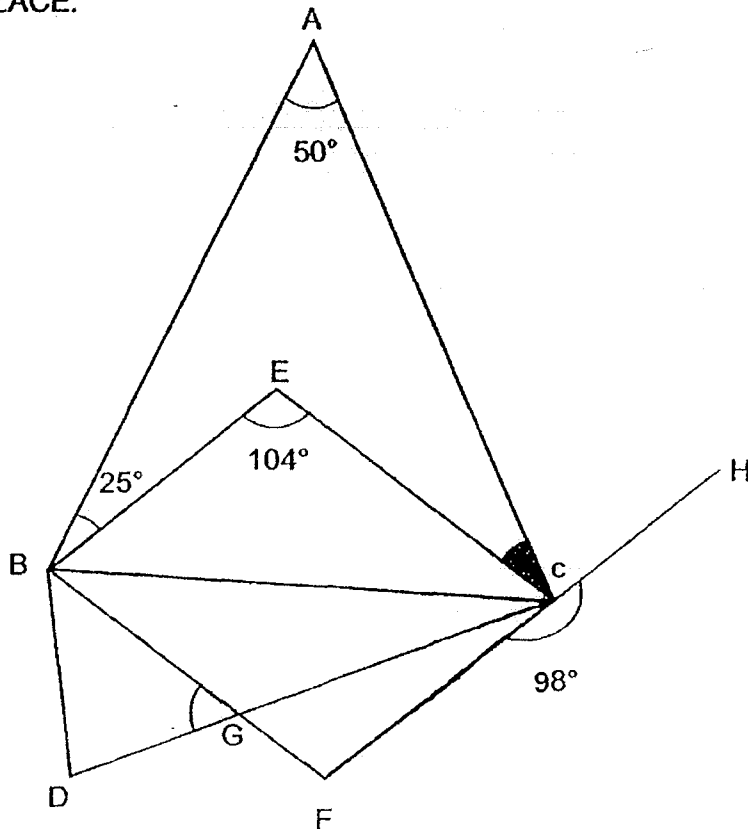

Ans: (a) _____ [2]

(b) _____ [2]

14. The mass of a container which is $\frac{3}{5}$ filled with flour is 10.84 kg. When $\frac{1}{3}$ of the flour is removed, the mass of the container and the remaining flour is 8.5 kg. Find the mass of the container.

Ans: _____ [4]

15. The figure is made up of a square of side 42cm, 2 identical big semicircles and 6 identical small semicircles.

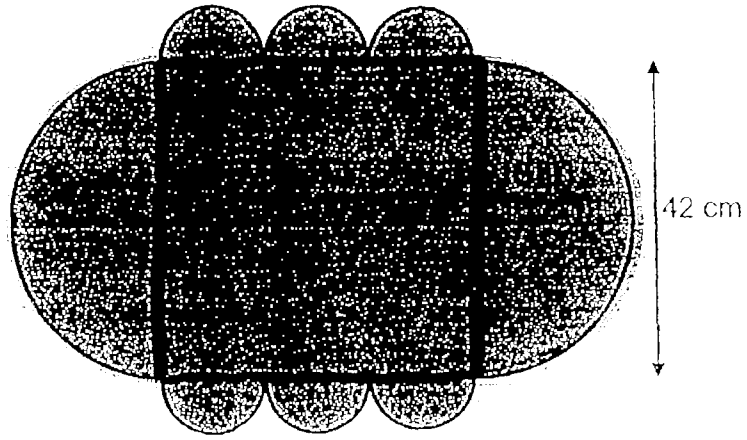

(a) What is the radius of each small semicircle?

(b) Find the area of the figure. Take $\pi = \frac{22}{7}$.

Ans: (a) _____ [1]

(b) _____ [3]

16. At Station A, the number of children was $\frac{3}{5}$ of the number of adults on the MRT. At Station B $\frac{2}{9}$ of the adults and some children alighted from the MRT. The number of children became $\frac{3}{7}$ of the number of adults. At Station C, 98 adults and 358 children boarded the MRT and there was an equal number of adults and children.

(a) How many passengers were there on the MRT after Station C?

(b) How many children alighted at Station B?

Ans: (a) _____ [4]

(b) _____ [1]

17. Mr Wong bought a number of red, blue and green balloons. The ratio of the number of red balloons to the number of blue balloons was 5 : 4 while the ratio of the number of blue balloons to the number of green balloons was 3 : 7. After bursting some green balloons and buying another 168 blue balloons, he found that there was a decrease of 25% in the total number of blue and green balloons. In the end, the number of red, blue and green balloons he had was 1440.

(a) How many balloons did Mr Wong have at first?

(b) How many green balloons were burst?

Ans: (a) _____ [3]

(b) _____ [2]

End of Paper

SCHOOL : RAFFLES GIRLS' PRIMARY SCHOOL
 LEVEL : PRIMARY 6
 SUBJECT : MATH
 TERM : 2019 PRELIM

PAPER 1 BOOKLET A

Q 1	Q2	Q3	Q4	Q5	Q6	Q7	Q8	Q9	Q10
3	2	2	3	3	1	4	3	4	3

Q 11	Q12	Q13	Q14	Q15
1	4	3	4	1

PAPER 1 BOOKLET B

Q16)	$\frac{75}{7} - \frac{56}{7} = \frac{19}{7}$
Q17)	$8 - 8 = 0$ $48 \times 0 = 0$
Q18)	1730
Q19)	0.495
Q20)	1.901
Q21)	$4536 - 3360 = 1176$ $1176 \div 24 = 49$
Q22)	$\frac{1}{5} \times \frac{2}{1} = \frac{2}{5}$ $\frac{2}{5} + \frac{2}{3} = \frac{6}{15} + \frac{10}{15}$ $= \frac{16}{15}$ $= 1\frac{1}{15}$
Q23)	$4000 \div 100 = 40$ $40 \times 1.5 = 60$
Q24)	$\frac{9p-15}{3}$
Q25)	C
Q26)	$19 \times 2 = 38$ $27 \times 2 = 54$

	$54+38=92$
Q27)	$100m \times 4 = 400m$ $10s+15s+13s+12s=50s$ $400m \div 50s = 8m/s$
Q28)	$5u + 7u = 12u$ $12u - 6u = 6u$ $6u \rightarrow 42$ $1u \rightarrow 42 \div 6 = 7$ $20u - 12u - 6u = 2u$ $2u \rightarrow 2 \times 7 = 14$
Q29)	$180^\circ - 117^\circ = 63^\circ$ $180^\circ - 63^\circ - 90^\circ = 27^\circ$
Q30)	$5u - 3u = 2u$ $2u \rightarrow 96$ $1u \rightarrow 96 \div 2 = 48$ $6u \rightarrow 48 \times 6 = 288$

PAPER 2

Q1)	$15u - 14u = 1u$ $1u \rightarrow 46$ $14u \rightarrow 46 \times 14 = 644$
Q2)	$180 - (34 \times 2) = 112$ $180 - (48 \times 2) = 84$ $112 - 84 = 28^\circ$
Q3)	$36 \div 2 = 18$ $36 + 24 = 60$ $60 - 33 - 18 = 9$ Total $\rightarrow 60 \times 2 = 120$ $\frac{9}{120} = \frac{3}{40}$
Q4)	$10 + 6 + 8 = 24$ (total length of wire) $24 \div 4 = 6$ (1 side of square) $\frac{1}{2} \times 6 \times 8 = 24$ $6 \times 6 = 36$ $36 - 24 = 12$ $\frac{12}{24} \times 100 = 50\%$
Q5)	a) True

	<p>b)Not possible to tell c)False</p>
Q6)	<p>$3T + 1S \rightarrow 81.76$ $1T + 2S \rightarrow 38.56 \times 3 = 115.68$ $115.68 - 81.76 = 33.92$ $33.92 \div 5 = 6.784$</p>
Q7)	<p>$E + M = 358$ $E + K = 698$ $698 - 358 = 340$ $5u - 1u = 4u$ $4u \rightarrow 340$ $1u \rightarrow 340 \div 4 = 85$ $358 - 85 = \\$273$</p>
Q8)	<p>a) $180^\circ - 110^\circ = 70^\circ$ b) $90^\circ - 40^\circ = 50^\circ$</p>
Q9)	<p>$3.14 \times 36 = 113.04$ $18 \times 2 = 36$ $\frac{1}{4} \times 3.14 \times 36 = 28.26$ $28.26 \times 2 = 56.52$ $36 \times 3 = 108$ $108 + 56.52 = 164.52\text{cm}$</p>
Q10)	<p>Valerie $\rightarrow \frac{25}{100} \times 140 = 35 (u)$ $140u + 35u = 175u (end)$ Isabelle $\rightarrow \frac{25}{100} \times 100u = 25u$ $100u - 25u = 75u$ Total (u) $\rightarrow 75u + 175u = 250u$ $250u \rightarrow 750$ $1u \rightarrow 750 \div 250 = 3$ $140u \rightarrow 140 \times 3 = 420$</p>
Q11)	<p>a)hot dog and chicken pies b) $48 + 75 + 75 + 100 = 298$ $\frac{48}{298} \times 100 \approx 16.1\%$</p>
Q12)	<p>a) $0.55 \times 50 = \\$27.50$</p>

	$b) 129.42 - 27.50 = 101.92$ $0.72 \times 100 = 72$ $101.92 - 72 = 29.92$ $29.92 \div 0.88 = 34$ $100 + 34 + 50 = 184\text{kw}$
Q13)	$a) 198 - 180 = 18$ (<GCF) $180 - 104 - 18 = 58^\circ$ (<CGF) $b) \angle EBD + \angle ECB \rightarrow 180 - 104 = 76$ $\angle ACE \rightarrow 180 - 50 - 76 - 25 = 29^\circ$
Q14)	$10.84 - 8.5 = 2.34$ $2.34 \times 2 = 4.68$ $8.5 - 4.68 = 3.82\text{kg}$
Q15)	$a) 42 \div 6 = 7\text{cm}$ $b) \frac{22}{7} \times 7 \times 7 = 154$ $154 \times 3 = 462$ $42 \div 2 = 21$ $\frac{22}{7} \times 21 \times 21 = 1386$ $42 \times 42 = 1764$ Total $\rightarrow 1764 + 1386 + 462 = 3612\text{cm}^2$
Q16)	$a) 15u + 358 = 358 + 98$ $358 - 98 = 35u - 15u$ $20u = 260$ $1u = 260 \div 20 = 13$ $15u \rightarrow 13 \times 15 = 195$ $195 + 358 = 553$ $553 \times 2 = 1106$ $b) 27u - 15u = 12u$ $12u \rightarrow 12 \times 13 = 156$
Q17)	$a) 28u + 12u = 40u$ $\frac{25}{100} \times 40 = 10$ $40u - 10u = 30u$ (now blue and green) $30u + 15u = 45u$ $45u \rightarrow 1440$ $1u \rightarrow 1440 \div 45 = 32$ $15u + 12u + 28u = 55u$ $55u \rightarrow 55 \times 32 = 1760$ $b) 15u \rightarrow 32 \times 15 = 480$ (red) $12u \rightarrow 12 \times 32 = 384$ (blue)

$$1440 - 480 - 384 - 168 = 408$$

$$28u \rightarrow 32 \times 28 = 896$$

$$896 - 408 = 488$$

RIVER VALLEY PRIMARY SCHOOL

PRELIMINARY EXAMINATION

2019

MATHEMATICS

PRIMARY SIX

Name : _____ ()

Class : Primary 6 (_____)

Date : 23 August 2019

Duration : 60 min (Total time for Booklets A and B)

PAPER 1

(BOOKLET A)

INSTRUCTIONSTO CANDIDATES

1. Write your Name, Register No. and Class in the space above.
2. Do not turn over this page until you are told to do so.
3. Follow all instructions carefully.
4. Answer all questions.
5. Shade your answers on the Optical Answer Sheet (OAS) provided.
6. You are not allowed to use a calculator.

Questions 1 to 10 carry 1 mark each. Questions 11 to 15 carry 2 marks each. For each question, four options are given. One of them is the correct answer. Make your choice (1, 2, 3 or 4). Shade the correct oval (1, 2, 3 or 4) on the Optical Answer Sheet. (20 marks)

1. What is the value of $10 \div 2000$?

- (1) 200
- (2) 0.5
- (3) 0.05
- (4) 0.005

2. The length of a public bus in Singapore is about _____.

- (1) 12 cm
- (2) 12 m
- (3) 120 cm
- (4) 120 m

3. How many eighths are there in $3\frac{1}{4}$?

- (1) 13
- (2) 24
- (3) 25
- (4) 26

4. The table below shows the programme guide for Nickadoo Channel.

Time	Programme
11 00	Mick Cat
11 45	Nature Whisper
12 50	Anna and Elsa (Movie)
14 15	Bob Cat

Elvis watched Nature Whisper and Anna and Elsa (Movie). How long did he spend watching both shows?

- (1) 1 h 5 min
 (2) 1 h 25 min
 (3) 1 h 50 min
 (4) 2 h 30 min
5. The figure below shows 11 squares. What is the smallest number of squares that must be added so that the line XY becomes a line of symmetry?

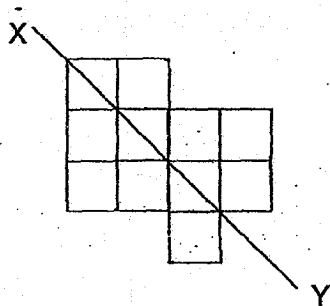

- (1) 1
 (2) 2
 (3) 3
 (4) 4

6. Which of the following letters has both parallel and perpendicular lines?
- (1) M X
 - (2) A X
 - (3) T X
 - (4) H
7. The original price of a bag was \$120. Linda bought it at a discount of 20%. How much did Linda pay for the bag?
- (1) \$24
 - (2) \$96
 - (3) \$100
 - (4) \$144
8. Ali was facing north-west at first. He then turned 225° anti-clockwise. Which direction would he be facing in the end?
- (1) North
 - (2) South
 - (3) East
 - (4) West

9. The pie chart shows the number of people at a party. Half of them are girls and women. How many boys are there at the party?

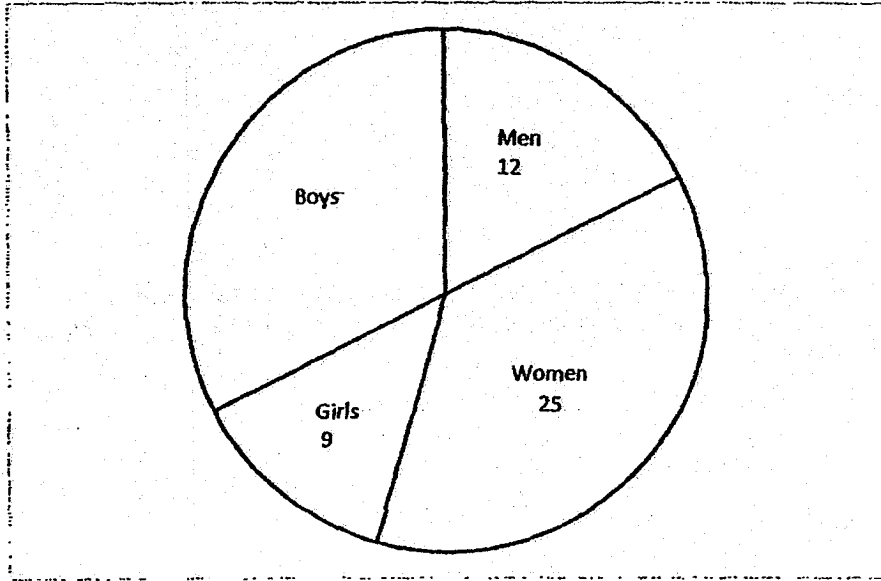

- (1) 16
- (2) 21
- (3) 22
- (4) 34

10. Razak read the timetable shown below for the train that leaves the MRT station for the airport.

Leaves MRT Station	Arrives at the airport
6.30 a.m.	7.15 a.m.
6.45 a.m.	7.30 a.m.
7.20 a.m.	8.05 a.m.
7.45 a.m.	8.30 a.m.
8.30 a.m.	9.15 a.m.

Razak wants to catch the latest train that will get him to the airport by 8.40 a.m. At what time does this train leave the MRT station?

- (1) 6.45 a.m.
(2) 7.20 a.m.
(3) 7.45 a.m.
(4) 8.30 a.m.
11. In the figure below, DEF is an isosceles triangle. $FD = FE$. DEH is a straight line, $\angle GEH = 25^\circ$ and $\angle DFE = 76^\circ$. Find $\angle FEG$.

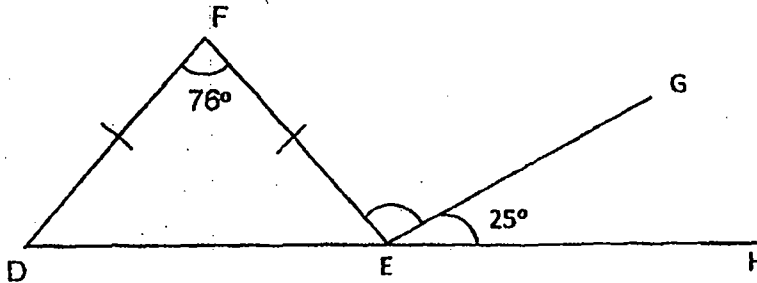

- (1) 104°
(2) 103°
(3) 77°
(4) 52°

12. In the figure below, ABCD is a trapezium and ABD is an equilateral triangle. $\angle BCD = 105^\circ$. Find $\angle CBD$.

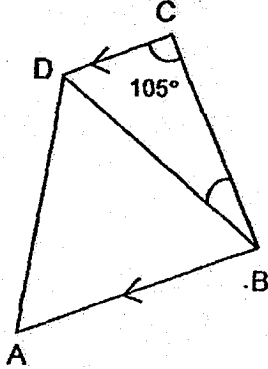

- (1) 15°
(2) 45°
(3) 60°
(4) 75°
13. The average mass of Alex, Ben and Charles is 49 kg. Alex is 9 kg heavier than Ben and 6 kg heavier than Charles. What is Charles' mass?

- (1) 44 kg
(2) 45 kg
(3) 48 kg
(4) 50 kg

14. James spent \$500 of his savings on Monday and $\frac{2}{5}$ of his remaining savings on Tuesday. After that, he found that he had $\frac{1}{3}$ of his original savings left. How much money did James spend on Tuesday?

- (1) \$125
- (2) \$250
- (3) \$625
- (4) \$1125

15. There is an equal number of stamps in Album A and Album B. The ratio of the number of local stamps to the number of foreign stamps in Album A is 3 : 2. In Album B, $\frac{4}{15}$ of the stamps are local stamps while the rest of the stamps are foreign stamps. What is the ratio of the total number of local stamps to the total number of foreign stamps in both albums?

- (1) 7 : 13
- (2) 13 : 7
- (3) 13 : 17
- (4) 17 : 13

- End of Booklet A -

**RIVER VALLEY PRIMARY SCHOOL
PRELIMINARY EXAMINATION**

2019

MATHEMATICS

PRIMARY SIX

Name : _____ ()

Class : Primary 6 (_____)

Date : 23 August 2019

Duration : 60 min (Total time for Booklets A and B)

**PAPER 1
(BOOKLET B)**

INSTRUCTIONSTO CANDIDATES

1. Write your Name, Register No. and Class in the space above.
2. Do not turn over this page until you are told to do so.
3. Follow all instructions carefully.
4. Answer all questions.
5. You are not allowed to use a calculator.

SUMMARY OF MARKS :

			Questions	Marks Awarded	Maximum Marks
Paper 1	Booklet A	MCQ	1 – 15		20
	Booklet B	SAQ	16 – 30		25
Paper 2		SAQ	1 – 5		10
		LAQ	6 - 17		45
	Total				100

Parent's Signature :

Questions 16 to 20 carry 1 mark each. Write your answers in the spaces provided. For questions which require units, give your answers in the units stated. (5 marks)

16. Write down all the common multiples of 4 and 9 that are smaller than 80.

Do not write
in this space

Ans: _____

17. Express 2.66 kilometres in metres.

Ans: _____ m

18. Express $\frac{6}{7}$ as a decimal. Round off your answer to 2 decimal places.

Ans: _____

19. The figure is formed by 3 straight lines. What is the value of $\angle a$.

Do not write
in this space

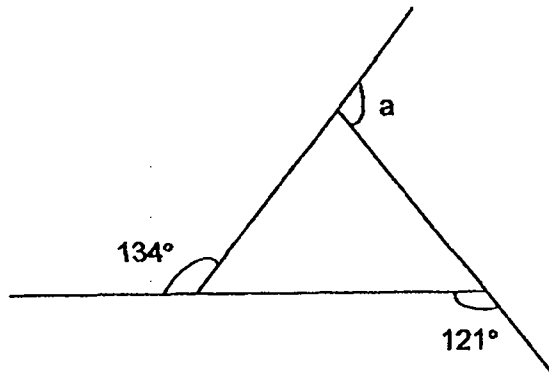

Ans: _____ °

20. The figure is made up of 5 identical squares. What percentage of the figure is shaded?

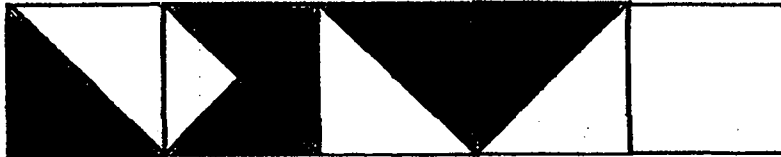

Ans: _____ %

Questions 21 to 30 carry 2 marks each. Show your working clearly and write your answers in the spaces provided. For questions which require units, give your answers in the units stated. (20 marks)

21. Alice was given an allowance of \$350 a month. She spent $\frac{4}{7}$ of her allowance each month. How much did she spend each month?

Do not write in this space

Ans : \$ _____

22. A rectangular tank measuring 50 cm by 30 cm by 20 cm is $\frac{2}{5}$ filled with water. How many litres of water are there in the tank?

Ans : _____ litres

23. The figure below is made up of 2 squares, ABCD and DWXY. GWF is a triangle. Find the area of the unshaded parts of the figure.

Do not write in this space

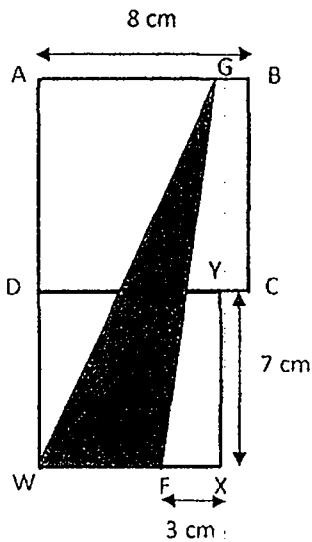

Ans: _____ cm²

24. The figure shows the net of a cuboid. The cuboid has a square base. Find the volume of the cuboid.

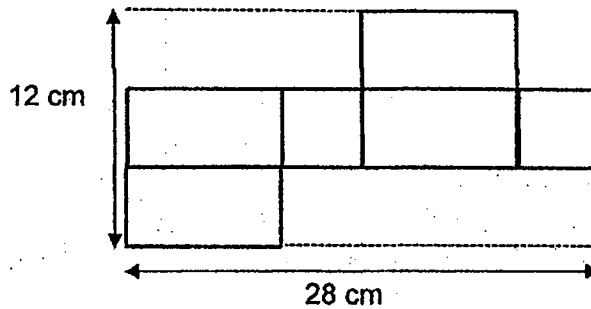

Ans: _____ cm³

25. Jaime is 13 years old. Her sister is r years younger than her. What is the sum of their age in 3 years' time?

Do not write
in this space

Ans: _____ years old

26. Rectangle WXYZ is made up of 6 identical small rectangles. The perimeter of Rectangle WXYZ is 120 cm. What is the area of each small rectangle?

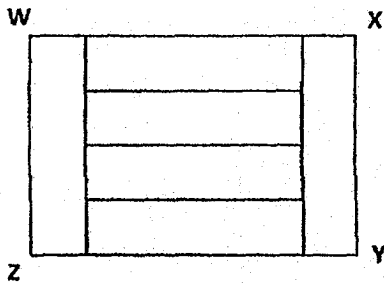

Ans: _____ cm²

27. The pie chart below shows the number of curry puffs sold by 4 teams in a carnival. The Green team sold half of the total number of curry puffs.

Do not write
in this space

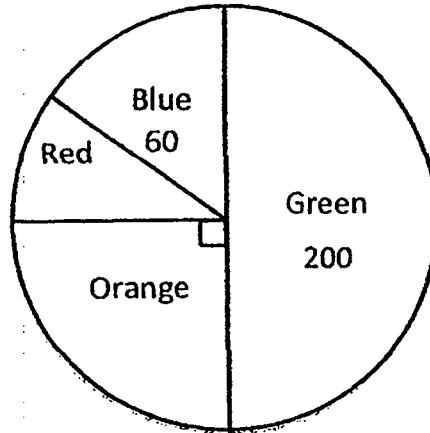

In the graph below, draw the bar to show the number of curry puffs sold by the Red and Orange teams.

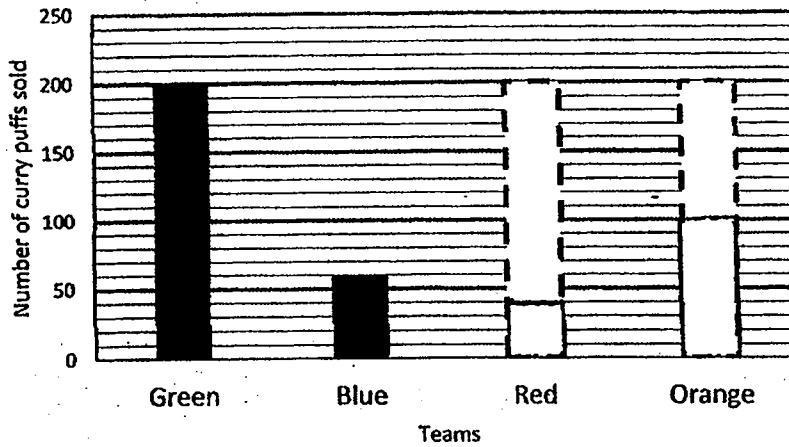

28. The figure below shows a rectangle WXYZ which is divided into 2 rectangles, WXVU and UVYZ. XV is 3 cm and VY is 6 cm. The area of triangle UVT is 24 cm^2 . Find the total area of the shaded parts.

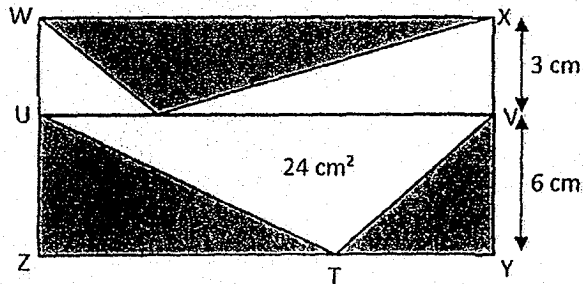

Do not write
in this space

Ans: _____ cm^2

29. Gopal and Salim took part in their school's fund-raising walk. Gopal's average speed was 20 m/min faster than Salim. When Gopal completed the walk in 40 min, Salim had only walked $\frac{3}{5}$ of the distance. Find Gopal's average speed for the walk.

Ans: _____ m/min

30. In the figure, CDEF is a square. JKH is an equilateral triangle. G is the midpoint of CF and JH is parallel to DE. $\angle JGH \approx 140^\circ$. Find $\angle GHK$.

Do not write
in this space

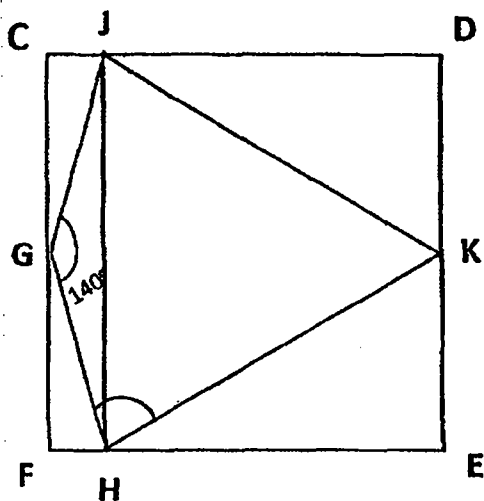

Ans: _____^o



- End of Booklet B -

RIVER VALLEY PRIMARY SCHOOL

PRELIMINARY EXAMINATION

2019

MATHEMATICS

PRIMARY SIX

Name : _____ ()

Class : Primary 6 (_____)

Date : 23 August 2019

Duration : 1 h 30 min

PAPER 2

INSTRUCTIONS TO CANDIDATES

1. Write your Name, Register No. and Class in the space above.
2. Do not turn over this page until you are told to do so.
3. Follow all instructions carefully.
4. Answer all questions.
5. You are allowed to use a calculator.

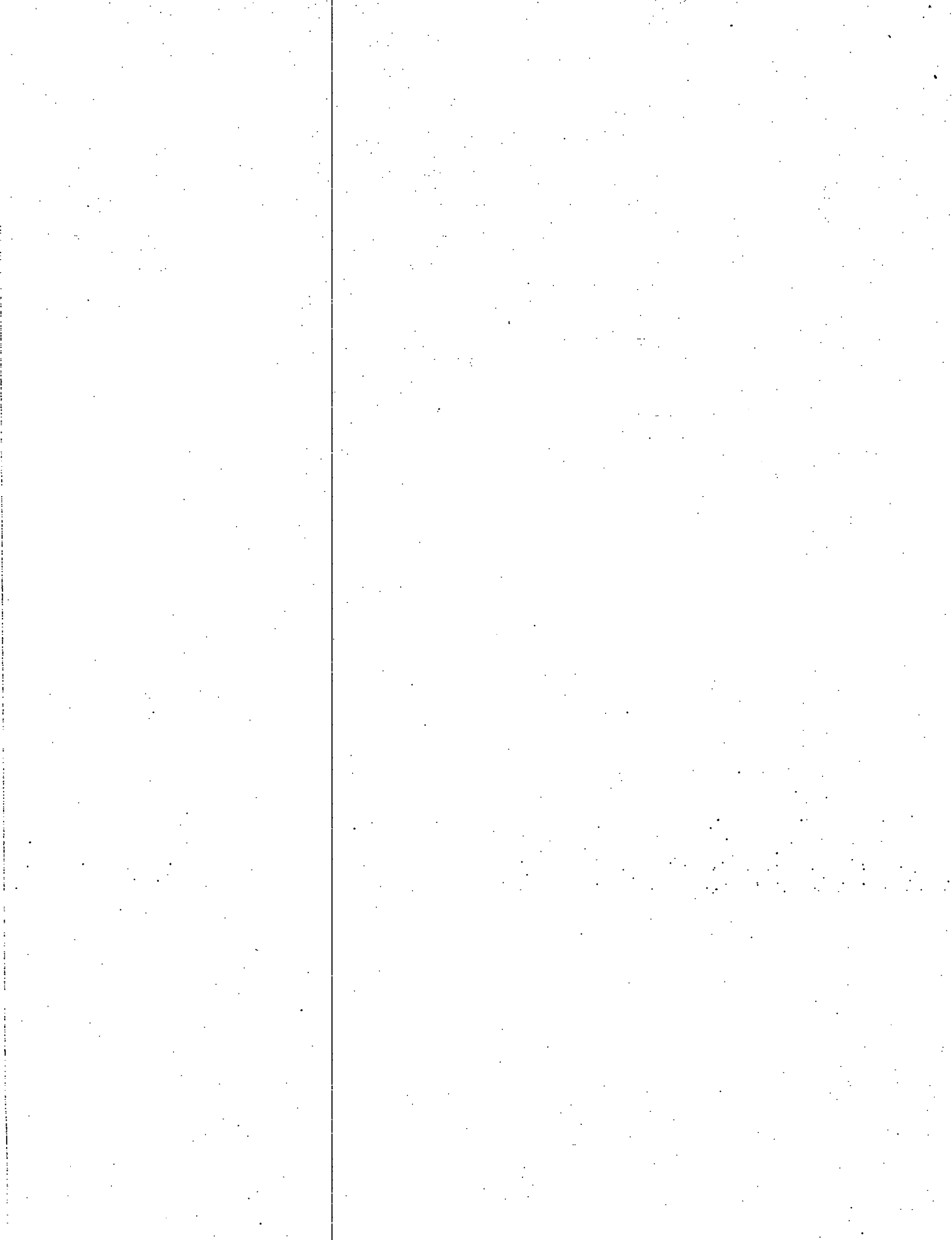

Questions 1 to 5 carry 2 marks each. Show your working clearly and write your answers in the spaces provided. For questions which require units, give your answers in the units stated. (10 marks)

1. 5 students took part in a donation drive. The table below shows the amount of money collected by the students. The amount collected by Charlie and Denise was not shown.

Do not write in this space

Students	Ahmad	Bala	Charlie	Denise	Emma
Amount collected	\$250	\$180			\$200

The average amount of money collected by the 5 students was \$320. Charlie collected \$170 less than Denise. How much money did Charlie collect?

Ans : \$ _____

2. There are 102 red and green flags hanging on a string. There are 3 green flags between any 2 red flags. What is the largest number of red flags on the string?

Ans : _____

3. In the figure, WXYZ is a parallelogram. GY is a straight line. $\angle WXY = 85^\circ$ and $\angle WGY = 120^\circ$. Find $\angle ZYG$.

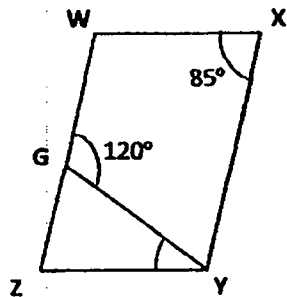

Do not write
in this space

Ans : _____

4. The diameter of a circle is 14 cm. (Take $\pi = \frac{22}{7}$)

Based on the information above, put a tick in the correct box below.

	True	False	Not possible to tell
(a) The area of the circle is 154 cm^2 .			
(b) When the diameter of the circle is doubled, the area of the new circle becomes 2 times the area of the original circle.			

5. In the square grid below, AB and BC are two sides of a rhombus ABCD.

Do not write
in this space

- (a) Complete and label the drawing of rhombus ABCD.
(b) Measure and write down the size of $\angle ABC$.

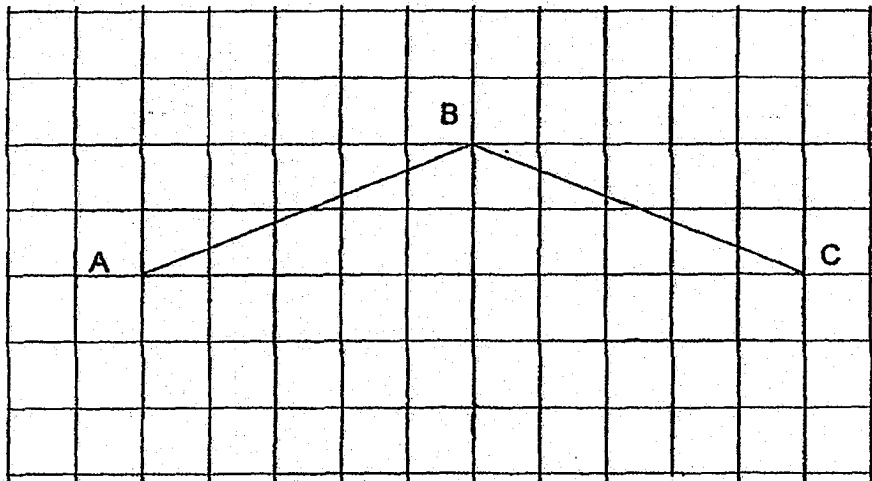

(1m)

Ans : (b) _____ °



For questions 6 to 17, show your working clearly and write your answers in the spaces provided. The number of marks available is shown in brackets () at the end of each question or part-question. (45 marks)

6. A company offered a total of 120 printers at a 25% discount over a 6-day sale. The line graph below shows the number of printers left unsold at the end of each day.

Do not write in this space

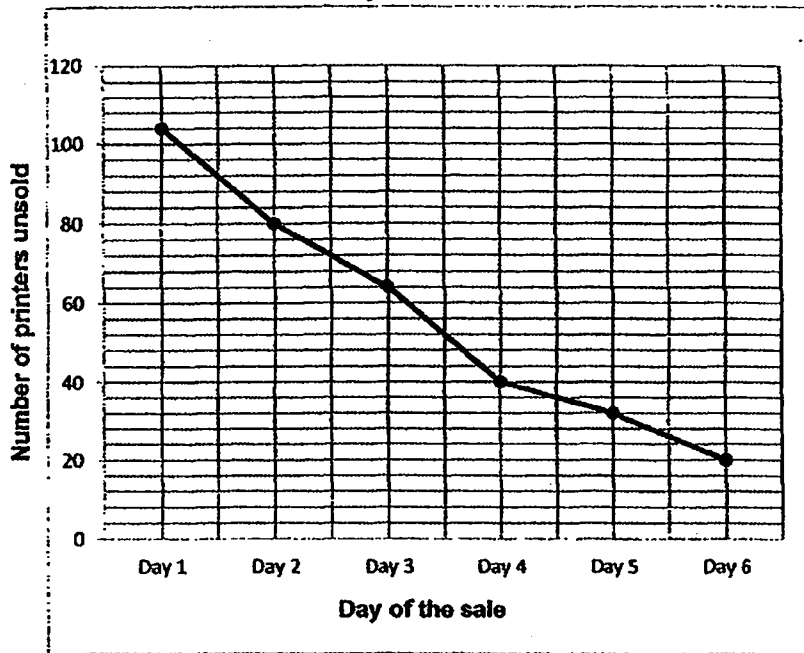

During the sale, the discounted price of each printer was \$150. After the 6-day sale, the remaining printers were sold without any discount. What was the total amount of money collected from selling all the 120 printers?

Ans: _____ (3m)



7. The table shows the number of pies baked by 3 bakers.

Names	Number of Pies
Alice	$p + 7$
Ben	$2p - 5$
Cindy	p

- (a) Find the total number of pies baked by the three bakers. Express your answer in terms of p .
- (b) If $p = 55$, find the average number of pies baked by the three bakers.

Ans: (a) _____ (1m)

(b) _____ (2m)

Do not write
in this space

8. Jack and Jill started cycling from the same place in opposite directions along a straight path. Jill cycled at a speed of 9 km/h. Jack cycled at a speed 2 times that of Jill. How far apart were they after cycling for 45 minutes?

Ans: _____ (3m)

9. Bernard stacked 9 cubes and glued them together to form the solid below.

Do not write in this space

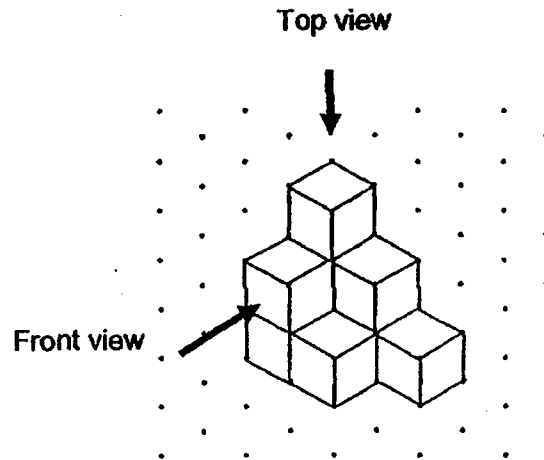

- (a) Draw the front view and top view of the solid on the grid below.
(2 marks)

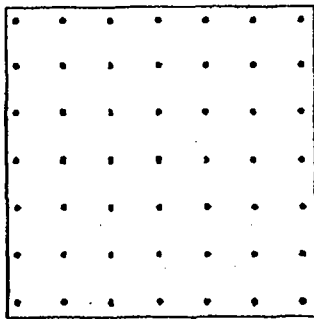

Front view

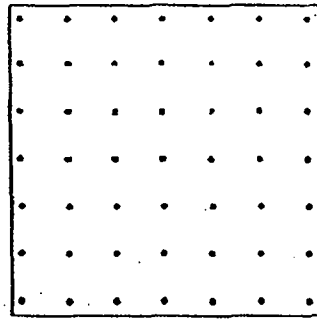

Top view

- (b) What is the minimum number of cubes Bernard has to add to the solid to make it into a bigger cube?

Ans: (b) _____ (1m)



10. The figure below is made up of two semi-circles and a right-angled triangle ABC. The diameter of the two semi-circles AB and BC are 12 cm and 16 cm respectively. The two semi-circles meet at X. AC is 20 cm. Find the area of the shaded area (Take $\pi = 3.14$)

Do not write
in this space

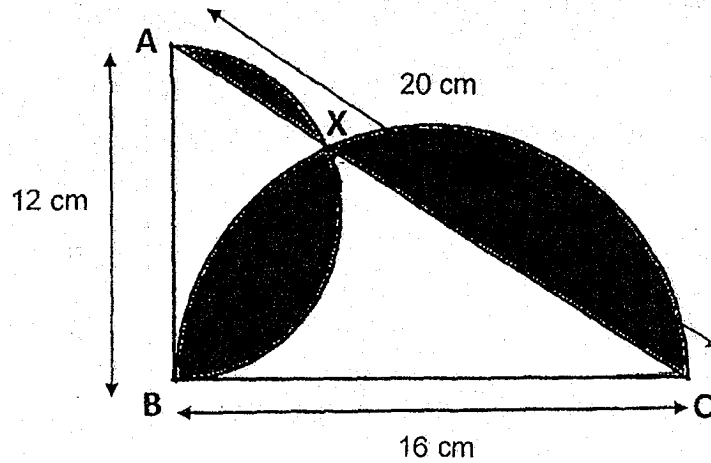

Ans : _____ (3m)



11. Mrs Lim baked some cupcakes. She sold $\frac{1}{4}$ of them in the morning and $\frac{3}{5}$ of them in the afternoon. She decided to bake another 252 cupcakes. The number of cupcakes she had in the end was $\frac{3}{4}$ as many as the number of cupcakes she had at first. How many cupcakes did Mrs Lim have in the end?

Do not write
in this space

Ans: _____ (3m)

12. Mrs Chandra bought $\frac{4}{5}$ as many pears as apples and $\frac{2}{5}$ as many mangoes as apples. She paid a total of \$150 for all the fruits. The ratio of the amount of money she spent on the apples to the amount she spent on the pears was 3 : 2. The ratio of the amount of money she spent on the pears to the amount of money she spent on the mangoes was 1 : 5. The cost of each apple was \$0.60. Find the total number of fruits Mrs Chandra bought.

Do not write
in this space

Ans : _____ (4m)

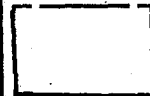

13. Li Ling had some \$2 notes and Anna had some \$5 notes. After Li Ling used $\frac{1}{4}$ of her notes and Anna used $\frac{2}{7}$ of her notes, they had the same number of notes left. If they had \$315 altogether in the end, how much money did Li Ling have at first?

Do not write
in this space

Ans: _____ (4m)



14. 250 boys and girls shared a sum of money. The average amount each child received was \$69.88. The average amount each boy received was \$55 and the average amount each girl received was \$85. How much more money did the girls receive than the boys?

Do not write
in this space

Ans : _____ (4m)



15. Stanley bought 4 times as many pencils as notebooks and 3 times as many erasers as notebooks. He spent a total of \$62.40 on these items. He spent \$9.60 more on the pencils than the notebooks and \$4.80 more on the notebooks than the erasers. Each notebook cost \$2.40 more than each eraser. How many pencils did Stanley buy?

Do not write
in this space

Ans : _____ (5m)



16. The figure below is made up of three identical overlapping circles and one equilateral triangle. Given that the area of the triangle is 63 cm^2 and the radius of each circle is 7 cm ,

Do not write
in this space

- a) Find the perimeter of the shaded part A.
b) Find the area of the shaded part B (Take $\pi = \frac{22}{7}$)

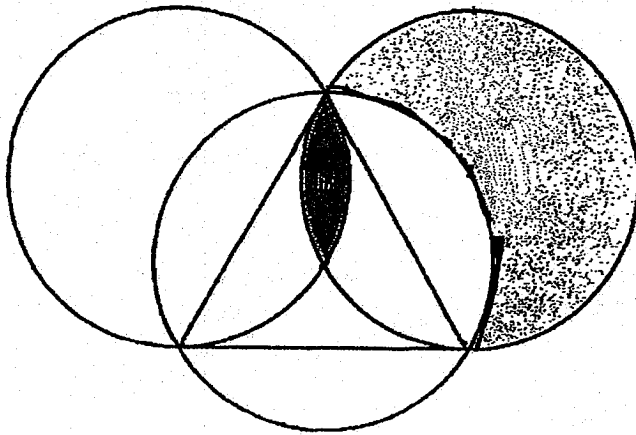

Ans : (a) _____ (1m)

(b) _____ (4m)

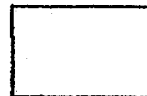

17. Bala uses shaded and unshaded squares to form figures that follow a pattern. The first three figures are shown below.

Do not write
in this space

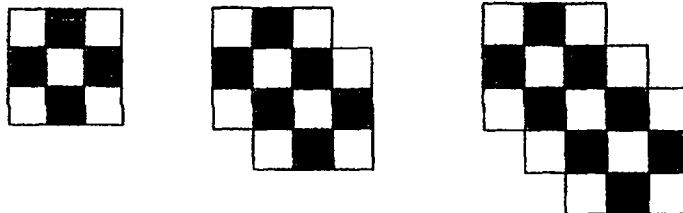

- (a) The table below shows the number of unshaded square for each figure.

Complete the table for Figure 4 and Figure 5. (1 mark)

Figure Number	Number of shaded squares	Number of unshaded squares
1	4	5
2	6	8
3	8	11
4	10	
5	12	

- (b) What is the difference in the number of unshaded squares Bala uses for Figure 11 and Figure 14?
- (c) Another figure in the pattern has 20 more unshaded than shaded squares. What is the total number of shaded and unshaded squares in that figure?

Ans : (b) _____ (2m)

(c) _____ (2m)



End of Paper 2 -

SCHOOL : RIVER VALLEY PRIMARY SCHOOL
LEVEL : PRIMARY 6
SUBJECT : MATH
TERM : 2019 PRELIM

PAPER 1 BOOKLET A

Q 1	Q2	Q3	Q4	Q5	Q6	Q7	Q8	Q9	Q10
4	2	4	4	2	4	2	3	3	3

Q 11	Q12	Q13	Q14	Q15
2	1	3	2	3

PAPER 1 BOOKLET B

Q16)	36 , 72
Q17)	2.66km = 2660m
Q18)	0.86
Q19)	$180^\circ - 134^\circ = 46^\circ$ $180^\circ - 121^\circ = 59^\circ$ $180^\circ - 46^\circ - 59^\circ = 75^\circ$ $\angle a = 180^\circ - 75^\circ = 105^\circ$
Q20)	$4u \times 5 = 20u$ $2u + 3ub + 2u + 2u = 9u$ $\frac{9}{20} \times 100\% = 45\%$

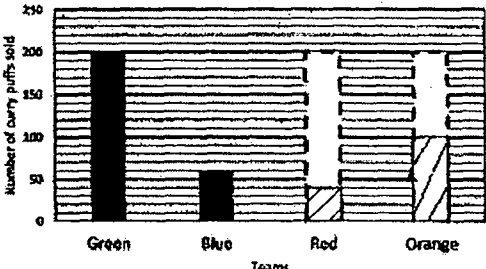
Q21)	$350 \div 7 = 50$ $50 \times 4 = \$200$
Q22)	$50 \times 30 \times 20 = 30000$ $30000 \div 5 = 6000$ $6000 \times 2 = 12000$ $12000\text{ml} = 12\text{litres}$
Q23)	$8 \times 8 = 64$ $7 \times 7 = 49$ $64 + 49 = 113$ $7 - 3 = 4$ $8 + 7 = 15$ $\frac{1}{2} \times 4 \times 15 = 30$ $113 - 30 = 83\text{cm}^2$
Q24)	$12 \div 3 = 4$ $28 - 4 - 4 = 20$ $20 \div 2 = 10$ $10 \times 4 \times 4 = 160\text{cm}^3$
Q25)	$13 - r$ $13 + 3 = 16$ $13 - r + 3 = 16 - r$ $16 + 16 - r = (32 - r)$ years old
Q26)	$4u + 1u + 1u = 6u$ $6u \times 2 = 12u$ $4u \times 2 = 8u$ $12u + 8u = 20u$ $20u \rightarrow 120$ $1u \rightarrow 120 \div 20 = 6$ $4u \rightarrow 6 \times 4 = 24$ $24 \times 6 = 144\text{cm}^2$
Q27)	 <p>2u → 200 1u → $200 \div 2 = 100$ (orange) $200 - 60 - 100 = 40$ (red)</p>

Q28)	$\frac{1}{2} \times 6 \times ? = 24$ $\frac{1}{2} \times 6 = 3$ $3 \times ? = 24$ $24 \div 3 = 8$	$\frac{1}{2} \times 3 \times 8 = 12$ $8 \times 6 = 48$ $48 - 24 = 24$ $24 + 12 = 36\text{cm}^2$
Q29)	$20\text{m/min} \times 40 = 800$ $800 \div 2 = 400$ $400 \times 5 = 2000$ $2000 \div 40 = 50\text{m/min}$	
Q30)	$\angle GHJ = (180^\circ - 140^\circ) \div 2 = 20^\circ$ $\angle GHK = 20^\circ + 60^\circ = 80^\circ$	

PAPER 2

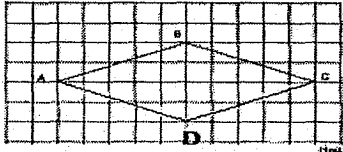
Q1)	$320 \times 5 = 1600$ $250 + 180 = 430$ $430 + 200 = 630$ $1600 - 630 = 970$ $970 - 170 = 800$ $800 \div 2 = \$400$	
Q2)	$102 \div 4 = 25$ $25 + 1 = 26$	
Q3)	$\angle ZGY = 180^\circ - 120^\circ = 60^\circ$ $\angle WXY = \angle WZY = 85^\circ$ $\angle ZYG = 180^\circ - 85^\circ - 60^\circ = 35^\circ$	
Q4)	a) True b) False	
Q5)	 <p>a)</p> <p>b) 137°</p>	

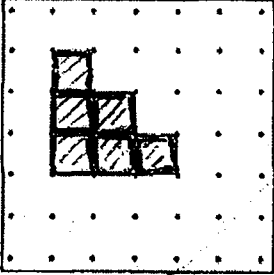
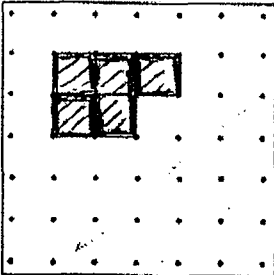
Q6)	$120 - 20 = 100$ $100 \times 150 = 15000$ $75\% \rightarrow 150$ $100\% \rightarrow \frac{150}{75} \times 100 = 200$ $200 \times 20 = 4000$ $4000 + 15000 = \$19000$
Q7)	<p>a) $p+7+2p-5+p = 2p+p+p+7-5$ $= 4p+7-5$ $= (4p+2)p$</p> <p>b) $55 \times 4 = 220$ $220 + 2 = 222$ $222 \div 3 = 74$</p>
Q8)	$18\text{km}/h \times \frac{3}{4}h = 13.5\text{km}$ $9\text{km}/h \times \frac{3}{4}h = 6.75\text{km}$ $13.5 + 6.75 = 20.25\text{km}$
Q9)	<p>a)</p> <div style="display: flex; justify-content: space-around; align-items: center;"> <div style="text-align: center;">  <p>Front view</p> </div> <div style="text-align: center;">  <p>Top view</p> </div> </div> <p>b) $3 \times 3 \times 3 = 27$ $27 - 9 = 18$</p>
Q10)	$3.14 \times 6 \times 6 \times \frac{1}{2} = 56.52$ $3.14 \times 8 \times 8 \times \frac{1}{2} = 100.48$ $100.48 + 56.52 = 157$ $\frac{1}{2} \times 12 \times 16 = 96$ $157 - 96 = 61\text{cm}^2$

Q11)	$\frac{3}{5} \times 4 = \frac{12}{20}$ $20u - 12u - 5u = 3u$ $15u - 3u = 12u$ $12u \rightarrow 252$ $1u \rightarrow 252 \div 12 = 21$ $21 \times 3 = 63$ $252 + 63 = 315$								
Q12)	<table style="width: 100%; border-collapse: collapse;"> <tr> <td style="width: 50%; text-align: center;">A : P : M</td> <td style="width: 50%; text-align: center;">P : A : M</td> </tr> <tr> <td style="text-align: center;">3 : 2</td> <td style="text-align: center;">4 : 5</td> </tr> <tr> <td style="text-align: center;">X2</td> <td style="text-align: center;">5 : 2</td> </tr> <tr style="border-top: 1px solid black;"> <td style="text-align: center;">3 : 2 : 10</td> <td style="text-align: center;">4 : 5 : 2</td> </tr> </table> $10u + 2u + 3u = 15u$ $15u \rightarrow 150$ $1u \rightarrow 150 \div 15 = 10$ $2u \rightarrow 10 \times 2 = 20$ $3u \rightarrow 10 \times 3 = 30$ $30 \div 0.60 = 50$ $50 \div 5 = 10$ $5u + 4u + 2u = 11u$ $11 \times 10 = 110$	A : P : M	P : A : M	3 : 2	4 : 5	X2	5 : 2	3 : 2 : 10	4 : 5 : 2
A : P : M	P : A : M								
3 : 2	4 : 5								
X2	5 : 2								
3 : 2 : 10	4 : 5 : 2								
Q13)	$\frac{4}{4} - \frac{1}{4} = \frac{3}{4}$ $\frac{7}{7} - \frac{2}{7} = \frac{5}{7}$ $15 \times 2 = 30$ $15 \times 5 = 75$ $75 + 30 = 105$ $315 \div 105 = 3$ $20 \times 3 = 60 \text{ (number of \$2 notes)}$ $60 \times 2 = \$120$								
Q14)	$10540 - 6930 = \$3610$								
Q15)	$3u = 62.40 - 9.6 - 4.8 - 4.8 = 43.20$ $1u = 43.20 \div 3 = 14.4 \text{ (TCE)}$ $\text{TCN} = 14.40 + 4.80 = 19.20$ $3p = 14.40$ $1p = 14.40 \div 3 = 4.80$ $19.20 - 4.80 = 14.40 \text{ (big diff)}$ $14.40 \div 2.40 = 6$ $6 \times 4 = 24$								

Q16) a) $\frac{22}{7} \times 14 = 44$
 b) $\frac{22}{7} \times 7 \times 7 = 154$
 $\frac{1}{2} \times 14 \times 7 = 49$
 $(154 - 49) \div 3 = 35 = 9\frac{1}{3}\text{cm}^2$

Q17) a)

Figure Number	Number of shaded squares	Number of unshaded squares
1	4	5
2	6	8
3	8	11
4	10	14
5	12	17

b)9

c) $62 + 42 = 104$



**ROSYTH SCHOOL
2019 PRELIMINARY EXAMINATION
MATHEMATICS
PRIMARY 6
PAPER 1**

Name: _____

Register No. _____

Class: Pr 6 - _____

Date: 27 August 2019

Parent's Signature: _____

Total Time for Booklets A and B : 1 hour

BOOKLET A

Instructions to Pupils:

1. Do not open this booklet until you are told to do so.
2. Follow all instructions carefully.
3. Shade your answers in the Optical Answer Sheet (OAS) provided.
4. You are **not** allowed to use a calculator.
5. Answer all questions.

Section	Maximum Mark	Marks Obtained
Paper 1 (Booklet A)	20	

* This booklet consists of 8 pages (including this cover page).

Questions 1 to 10 carry 1 mark each. Questions 11 to 15 carry 2 marks each.
For each question, four options are given. One of them is the correct answer.
Make your choice (1, 2, 3 or 4). Shade the oval (1, 2, 3 or 4) on the Optical Answer Sheet.

All diagrams in this paper are not drawn to scale unless stated otherwise.

(20 marks)

1. Round 263 547 to the nearest hundred.

- (1) 260 000
- (2) 263 500
- (3) 263 550
- (4) 264 000

2.

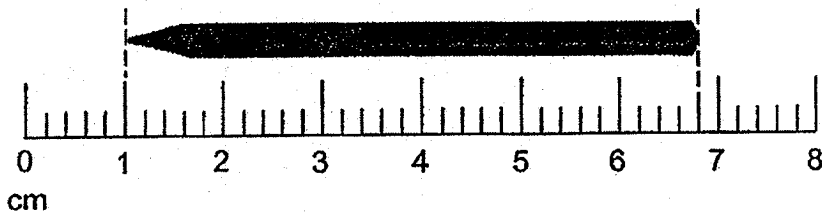

What is the length of the pencil?

- (1) 5.4 cm
- (2) 5.8 cm
- (3) 6.4 cm
- (4) 6.8 cm

3. Find the value of $\frac{5y+12}{6}$ when $y = 6$.

(1) 7

(2) 10

(3) 17

(4) 32

4. Troy took 2 h 15 min to bake a cake. He started baking at 11.35 a.m. What time did he finish baking?

(1) 1.00 p.m.

(2) 1.15 p.m.

(3) 1.35 p.m.

(4) 1.50 p.m.

5. How many letters below have both parallel and perpendicular lines?

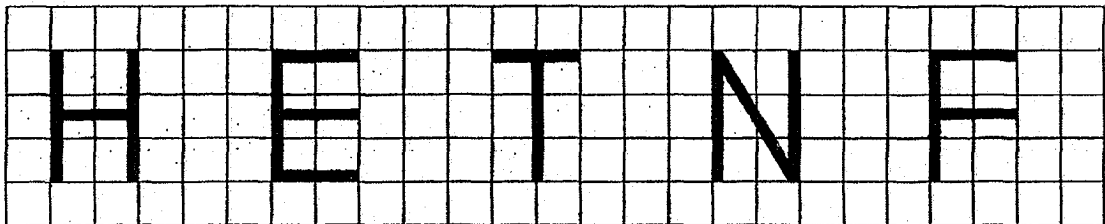

(1) 5

(2) 2

(3) 3

(4) 4

6. Karen is thinking of a quadrilateral.
Using the clues below, which of the following shapes, A, B, C, or D is Karen thinking of?

Clue 1: It has two pairs of parallel sides.

Clue 2: Not all angles are the same size.

Clue 3: Not all sides are the same length.

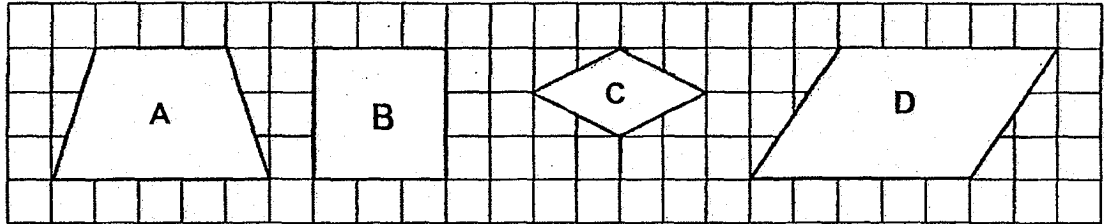

- (1) A
(2) B
(3) C
(4) D
7. The square grid below shows the plan of a town.

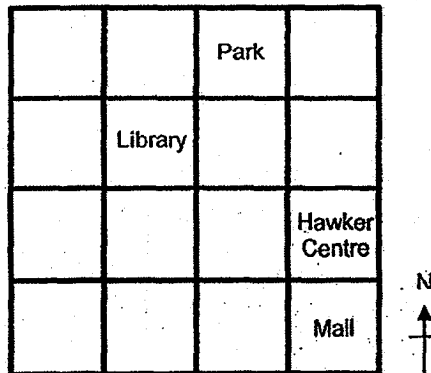

Which direction is the library from the mall?

- (1) North-east
(2) South-west
(3) North-west
(4) South-east

8. A machine can print 80 cards in 3 minutes. At this rate, how many cards can it print in 1 hour?

- (1) 240
- (2) 1 600
- (3) 4 800
- (4) 14 400

9. The figure below shows a pyramid.

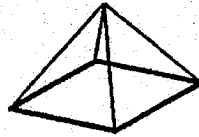

Which of the following is **not** a net of the pyramid?

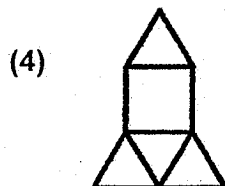
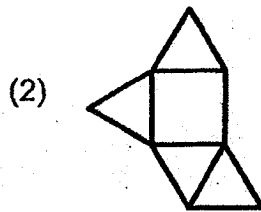
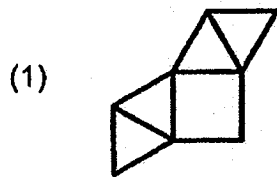

10. The graph shows the number of visitors at the zoo from Monday to Thursday. On which two days were there the same number of visitors at the zoo?

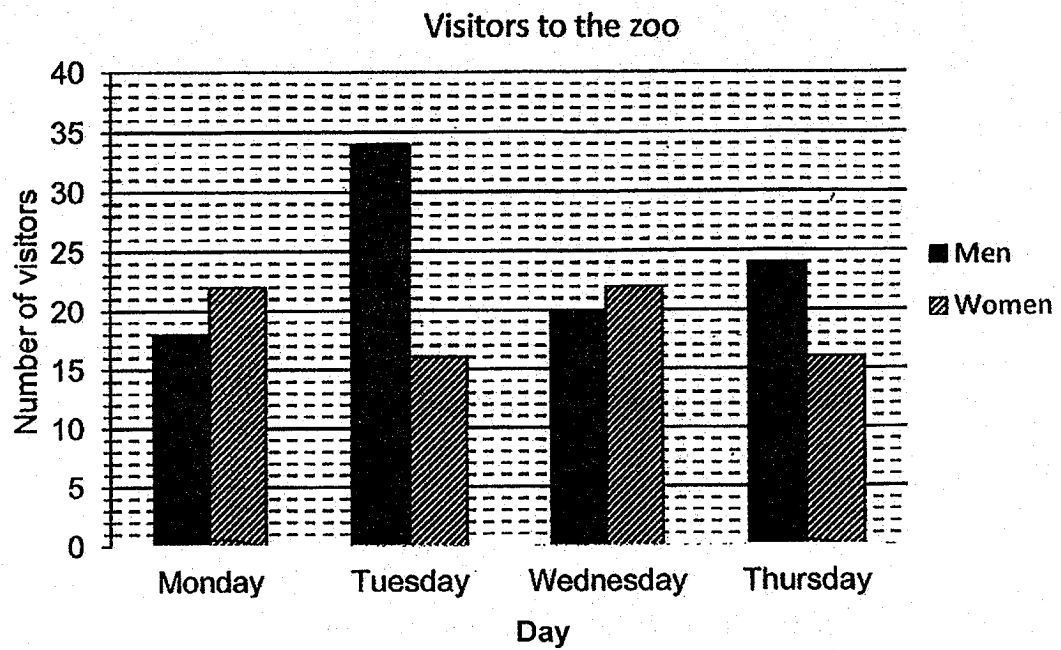

- (1) Monday and Tuesday
- (2) Monday and Thursday
- (3) Wednesday and Thursday
- (4) Tuesday and Thursday
11. Andrea had 24 more stamps than Bella. When Bella gave 18 stamps to Andrea, Andrea had 4 times as many stamps as Bella. How many stamps did Bella have at first?

- (1) 14
- (2) 20
- (3) 32
- (4) 38

12. An electronics store sold $\frac{5}{8}$ of their television sets in the morning, $\frac{1}{3}$ of the remaining television sets in the afternoon and the rest of the television sets in the evening. What fraction of the television sets were sold in the evening?

(1) $\frac{1}{4}$

(2) $\frac{2}{3}$

(3) $\frac{1}{24}$

(4) $\frac{5}{24}$

13. The equilateral triangle and the rectangle shown below have the same perimeter. The length of the rectangle is twice its breadth. The side of the triangle is 12 cm. What is the area of the rectangle?

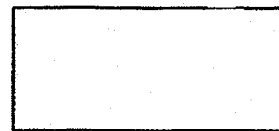
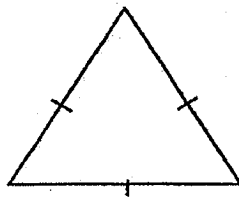

12 cm

(1) 9 cm^2

(2) 24 cm^2

(3) 72 cm^2

(4) 81 cm^2

14. John, Michael and Terry shared \$27.90 among themselves. Terry received 3 times as much money as Michael and John received twice as much money as Michael. How much money did John receive?
- (1) \$3.10
 - (2) \$4.65
 - (3) \$6.20
 - (4) \$9.30
15. Claire bought a bottle containing 2.85 litres of washing detergent. She used 40 ml of washing detergent each day from Monday to Friday. On Saturday and Sunday, she used 50 ml of washing detergent each day. If Claire started using a new bottle on Tuesday, on which day would she use up all the washing detergent?
- (1) Monday
 - (2) Tuesday
 - (3) Thursday
 - (4) Friday



**ROSYTH SCHOOL
2019 PRELIMINARY EXAMINATION
MATHEMATICS
PRIMARY 6
PAPER 1**

Name: _____

Register No. _____

Class: Pr 6 - _____

Group: _____

Date: 27 August 2019

Parent's Signature: _____

Total Time for Booklets A and B : 1 hour

BOOKLET B

Instructions to Pupils:

1. Do not open this booklet until you are told to do so.
2. Follow all instructions carefully.
3. You are **not** allowed to use a calculator.
4. Write your answers in the booklet.
5. Answer all questions.

Section	Maximum Mark	Marks Obtained
Paper 1 (Booklet B)	25	

* This booklet consists of 9 pages (including this cover page).

Questions 16 to 20 carry 1 mark each. Write your answers in the spaces provided. For questions which require units, give your answers in the units stated.

All diagrams in this paper are not drawn to scale unless stated otherwise.
(5 marks)

Do not write
in this space

16. Find the value of $8.2 - 2.33$.

Ans: _____

17. Express 6 minutes as a percentage of 2 hours.

Ans: _____ %

18. In the grid below, draw two straight lines to form a symmetric figure with AB as the line of symmetry.

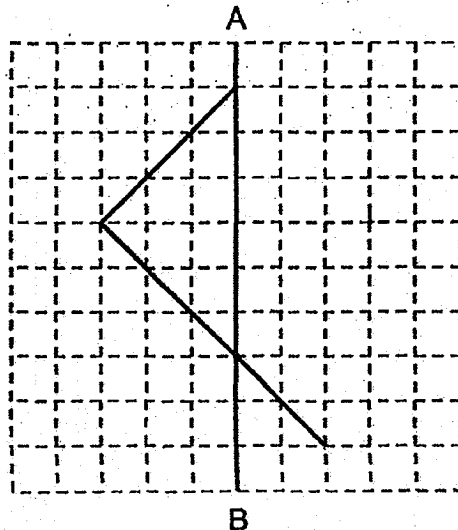

19. A rectangular container measuring 10 cm by 20 cm by 37 cm is $\frac{1}{4}$ filled with water. Find the volume of water in the container.

Do not write
in this space

Ans: _____ cm³

20. The pie chart below shows the number of cakes sold at a shop from Tuesday to Friday.

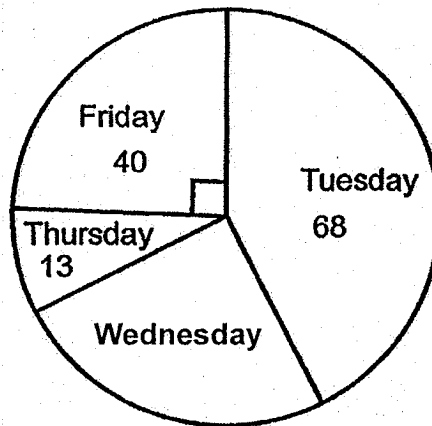

The number of cakes sold from Tuesday to Friday is also represented by the table below. Find the number of cakes sold on Wednesday.

Day	Number of cakes sold
Tuesday	68
Wednesday	?
Thursday	13
Friday	40

Ans: _____

Questions 21 to 30 carry 2 marks each. Show your workings clearly in the space provided for each question and write your answers in the spaces provided. For questions which require units, give your answers in the units stated.

Do not write
in this space

All diagrams in this paper are not drawn to scale unless stated otherwise.
(20 marks)

21. Miss Teo gave her students some sweets. If she gave each student 4 sweets, there were 3 sweets left over. If she gave each student 6 sweets, she was short of 1 sweet. What was the smallest possible number of sweets that Miss Teo gave her students?

Ans: _____

22. The table below shows the marks that Hayden scored for 4 subjects in the SA1 examinations.

Subject	Marks
English	72
Mathematics	65
Mother Tongue	?
Science	80

Hayden scored an average of 72 marks for the 4 subjects. How many marks did he score for his Mother Tongue?

Ans: _____

23. Muthu bought 3 types of stationery items for his office. The prices are given in the table below.

Type of stationery item	Price per item
Pencil	\$0.50
Pen	\$2.00
File	\$4.00

Do not write
in this space

The bar graph shows the total cost spent on each type of stationery items.

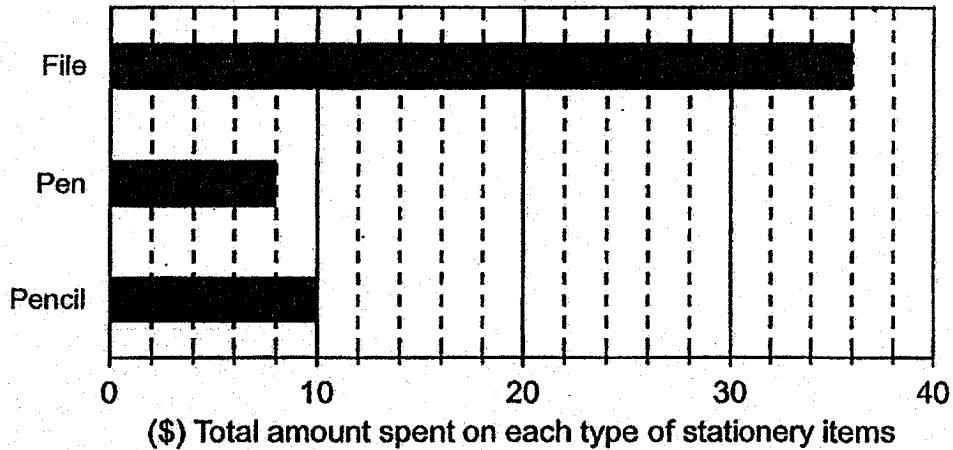

What is the total number of stationery items bought by Muthu?

Ans: _____



24. The figure below is made up of a semi-circle and an equilateral triangle.
Find the perimeter of the figure. Take $\pi = \frac{22}{7}$.

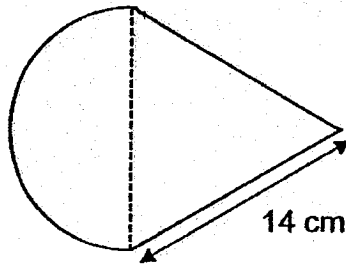

Ans: _____ cm

25. In a 100 m race, when Patrick reached the finishing point, he was 20 m ahead of Raj and 40 m ahead of Salim. All the boys did not change their speed throughout the race. How far had Salim run when Raj reached the finishing point?

Ans: _____ m

Do not write
in this space



26. In the square grid below, XY is a straight line.
 Draw an isosceles triangle XYZ using one of the given points as point Z .

Do not write
 in this space

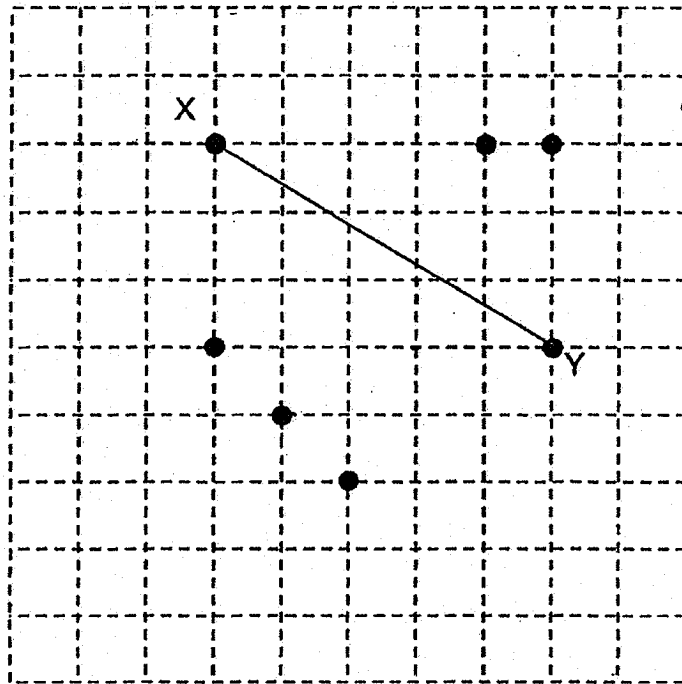

27. A total of 77 people are standing in a queue for concert tickets. There are at least 3 women in between every 2 men. What is the largest possible number of men in the queue?

Ans: _____



28. Mdm Farah baked an equal number of cupcakes and cookies. After she sold 32 cupcakes and 20 cookies, the number of cupcakes left was $\frac{4}{7}$ of the number of cookies left. How many cookies did she bake at first?

Do not write
in this space

Ans: _____



29. In the figure, ABC is an isosceles triangle. $\angle BCD = 220^\circ$ and $\angle ACD = 60^\circ$. Find $\angle BAC$.

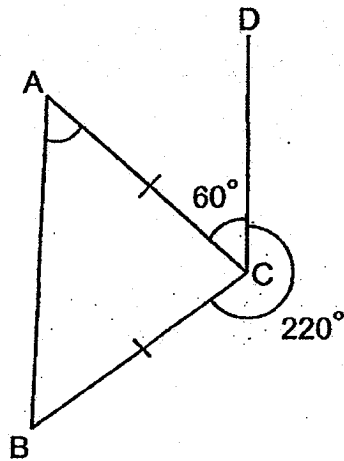

Ans: _____°



30. On Monday, Alynna has \$90 while Rachel has \$10 in each of their savings account. On Tuesday, both Alynna and Rachel start saving a fixed amount daily. Rachel saves \$2 more than Alynna each day. After 10 days Alynna has twice as much money as Rachel. How much does Alynna save each day ?

Do not write
in this space

Ans: \$ _____



End of paper



ROSYTH SCHOOL
2019 PRELIMINARY EXAMINATION
MATHEMATICS
PRIMARY 6
PAPER 2

Name: _____ Register No. _____

Class: Pr 6 - _____

Date: 27th August 2019 Parent's Signature: _____

Time: 1h 40mins

Instructions to Pupils:

1. Do not open this booklet until you are told to do so.
2. Follow all instructions carefully.
3. **Show your workings clearly** as marks are awarded for correct working.
4. Write your answers in this booklet.
5. You are allowed to use a calculator.
6. Answer all questions.

Questions	Maximum Mark	Marks Obtained
Q 1 to 5	10	
Q 6 to 18	45	

Section	Maximum Mark	Marks Obtained
Paper 1	45	
Paper 2	55	
Total	100	

* This booklet consists of 15 pages (including this cover page)

Questions 1 to 5 carry 2 marks each. Show your working clearly in the space provided for each question and write your answers in the spaces provided. For questions which require units, give your answers in the units stated.

(10 marks)

Do not write
in this space

All diagrams in this paper are not drawn to scale unless stated otherwise.

1. Joel had $6p$ marbles. He had half as many marbles as Amanda. Amanda had 8 more marbles than Raju. How many marbles did they have altogether?

Ans: _____

2. James has $\frac{1}{4}$ as many sweets as Ahmad and $\frac{4}{5}$ as many sweets as Muthu. They have a total of 325 sweets. How many sweets does Muthu have?

Ans: _____

3. Two identical triangles overlapped each other to form six smaller identical equilateral triangles as shown below. The area of the shaded part is 78 cm^2 . Find the area of 1 unshaded equilateral triangle.

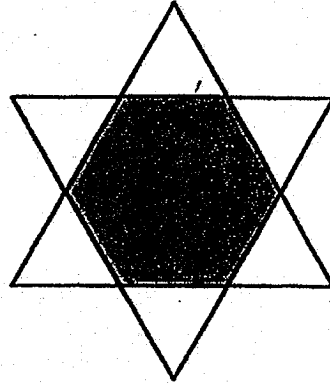

Do not write
in this space

Ans: _____ cm^2

4. In an examination hall, the tables were arranged in such a way that there were 15 rows with 30 tables in each row on Day 1. On Day 2, 8 tables were removed from each row and the remaining tables were then rearranged such that there were 33 tables in each row.

Statement	True	False	Not possible to tell
a) There were 442 tables left on Day 2.			
b) There were 10 rows of tables on Day 2.			

5. A rectangular tank was filled with some water at first. Tap A was first turned on to add more water into the tank for 20 minutes. After 10 minutes, Tap B was then turned on to drain water out of the tank until the 20th minute. The line graph shows the volume of water in the tank over the period of 20 minutes.

Do not write
in this spac

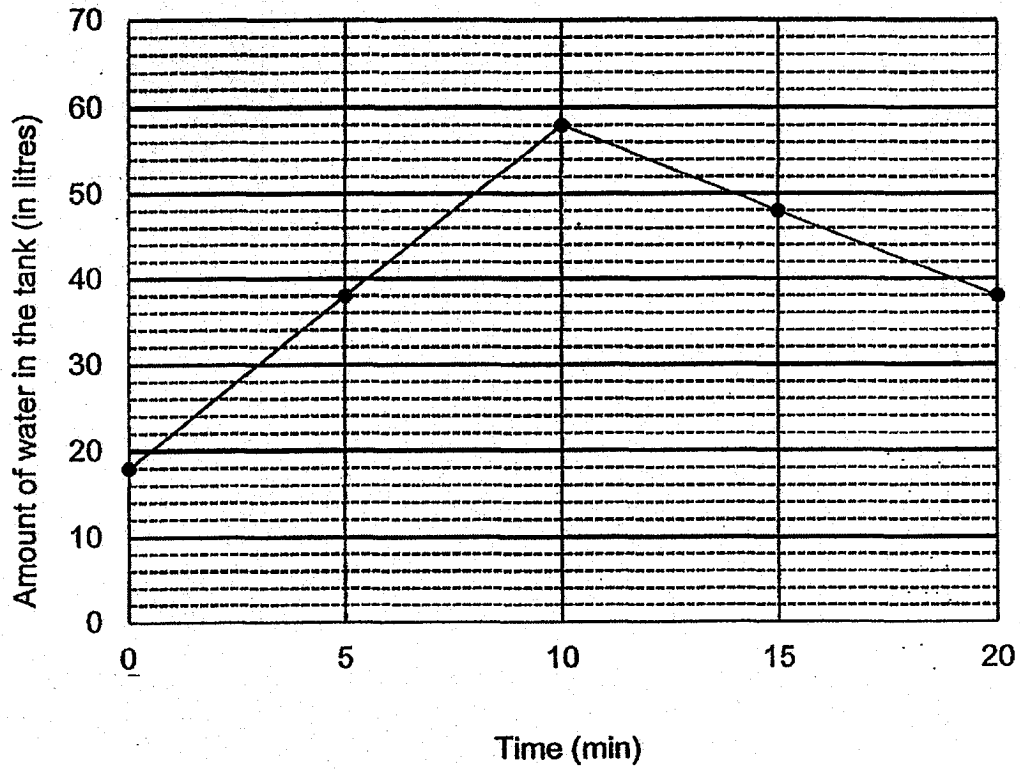

How many litres of water did Tap B drain out?

Ans: _____ l

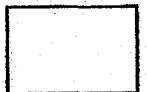

For Questions 6 to 10, show your working clearly in the space provided for each question and write your answers in the spaces provided. The number of marks available is shown in brackets [] at the end of each question or part-question. For questions which require units, give your answers in the units stated.

Do not write
in this space

All diagrams in this paper are not drawn to scale unless stated otherwise.
(50 marks)

6. $\frac{1}{3}$ of Julie's money was equal to $\frac{3}{5}$ of Nancy's money. After Julie gave Nancy \$42, both of them would have the same amount of money. How much money did Nancy have at first?

Ans: _____ [3]

7. Andy had just enough ribbon to cut into 45 shorter pieces of equal length. However, if he cut the ribbon into 37 pieces of equal length, he would have 5.04 m of ribbon left. What was the length of ribbon?

Ans: _____ [3]

8. Tony wants to sell a laptop. The table shows the prices of the same laptop from his shop and Shop Y.

Do not write
in this space

Tony's shop		Shop Y	
Original Price	% Discount	Original Price	% Discount
\$ 3 500	?	\$4 000	30%

Tony wants to price his laptop at the same selling price as Shop Y. How much percentage discount must he give to match Shop Y's selling price?

Ans: _____ [3]

9. Alfred left his house for Zain's house. Alfred wants to reach Zain's house at 6.00 p.m. If Alfred walks at a speed of 60 m/min, he will be 16 minutes late. If he jogs at a speed of 80 m/min, he will be 6 minutes late. What is the distance between Alfred's and Zain's house?

Do not write
in this space

Ans: _____ [3]



10. In the diagram below, PQS is an equilateral triangle. QT is a straight line. $PR \perp QS$, $\angle PQV = 35^\circ$ and $\angle PST = 75^\circ$. Find

(a) $\angle QPR$

(b) $\angle QTS$

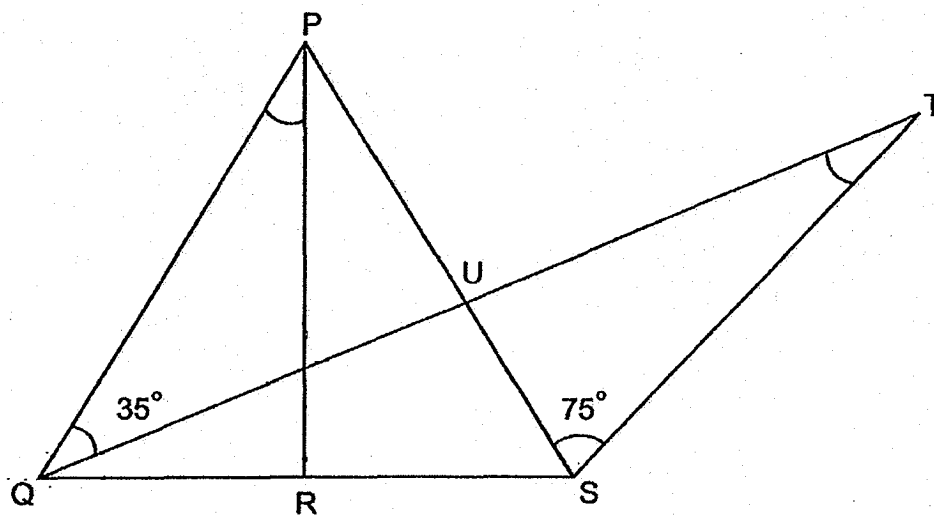

Do not write
in this space

Ans: (a) _____ [1]

(b) _____ [2]

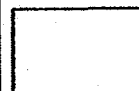

11. The figure consists of 2 identical rectangles, ABCD and EFGH, overlapping one another. EBCH is a square. The area of each rectangle is 280 cm^2 . 40% of the whole figure is shaded. The unshaded area of the whole figure is 360 cm^2 . What is the ratio of triangle EXH to the area of ADGF?

Do not write
in this spac

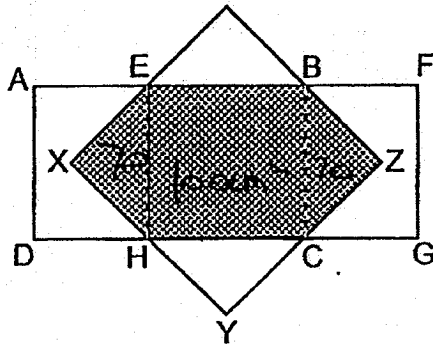

Ans: _____ [4]



12. The number of visitors to a zoo was 152 880 in July. This was a 16% decrease from the number in June. The number of people who visited the zoo in August was a 20% increase from the number in July.

- (a) What was the total number of people who visited the zoo in June?
- (b) What was the percentage increase in the number of people who visited the zoo in August compared to June?

Do not write
in this space

Ans: (a) _____ [2]

(b) _____ [2]



13. The diagram below shows 2 tanks Tank A and Tank B of different dimensions. Tank A is completely empty while Tank B is filled with water to the brim.

Do not write in this space

(a) Find the volume of water in Tank B.

(b) Water from Tap A flows at a rate of 2.7 litres per minute while water drains from Tap B at a rate of 2.4 litres per minute. Both taps are turned on at the same time. After some time, the height of the water level in both tanks becomes the same. Find the height of the water level at this point of time.

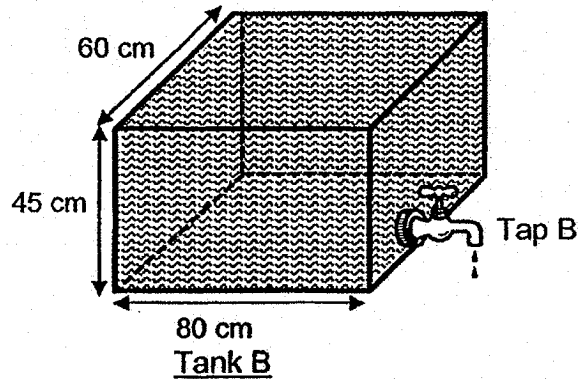
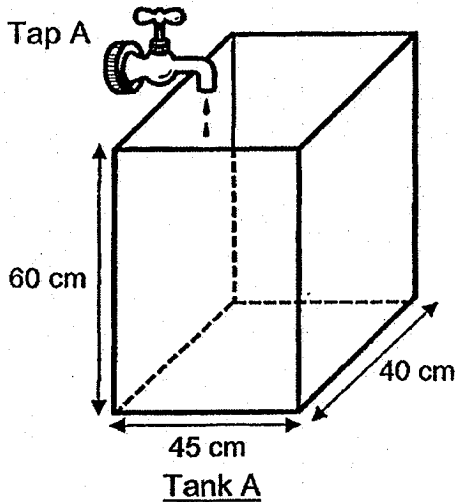

Ans: (a) _____ [1]

(b) _____ [3]



14. In the figure, ABDE is a trapezium and $AC \parallel ED$. Find

(a) $\angle CFE$

(b) $\angle FED$

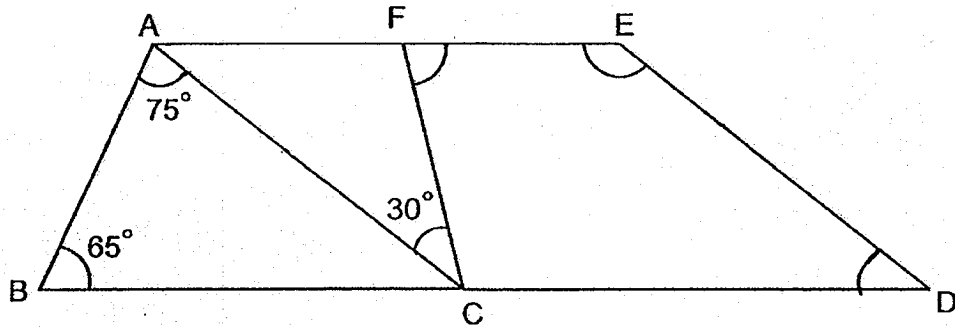

Do not write
in this space

Ans: (a) _____ [2]

(b) _____ [2]

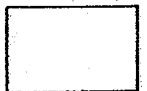

15. Mrs Raju wanted to decorate the bulletin board with some circular pieces of paper. The diameter of each circular paper was 12 cm. She cut all the circular pieces of paper into quadrants and decorated the entire bulletin board using all the quadrants, following the pattern shown below. There was no gap between each piece of quadrant.

Do not write in this space

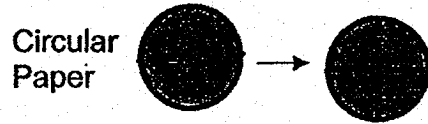

How many pieces of circular paper did she use to decorate the bulletin board?

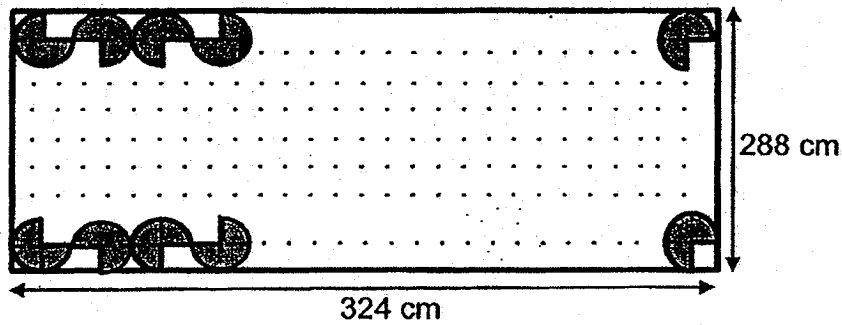

Ans: _____ [4]



16. There were 200 more apples than pears at a fruit stall. After $\frac{1}{4}$ of the apples and $\frac{2}{7}$ of the pears were sold, there were 170 more apples than pears left.

(a) How many apples were there at the fruit stall at first?

(b) How many pears were left at the fruit stall in the end?

Do not write
in this space

Ans: (a) _____ [3]

(b) _____ [2]



17. A chef prepared some fishballs for the guests during a birthday party. 60% of the guests were children. Among the children, the ratio of the number of girls to the number of boys is 5 : 3. A total of 9 408 fishballs were prepared so that each adult got 5 fishballs and each child got 6 fishballs. There were no fishballs left after the party.

a) What was the ratio of the number of fishballs the adults got to the number of fishballs the children got?
Give your answer in the simplest form.

b) How many boys attended the party?

Do not write
in this space

Ans: (a) _____ [3]

(b) _____ [2]



End of Paper

SCHOOL : ROSYTH PRIMARY SCHOOL
 LEVEL : PRIMARY 6
 SUBJECT : MATH
 TERM : 2019 PRELIM

PAPER 1 BOOKLET A

Q 1	Q2	Q3	Q4	Q5	Q6	Q7	Q8	Q9	Q10
2	2	1	4	3	4	3	2	3	2

Q 11	Q12	Q13	Q14	Q15
4	1	3	4	4

PAPER 1 BOOKLET B

Q16)	$8.20 - 2.33 = 5.87$
Q17)	<p>$2\text{hours} = 120\text{minutes}$</p> <p>$\frac{6}{120} = \frac{1}{20}$</p> <p>$\frac{1}{20} \times 100 = 5\%$</p>
Q18)	

Q19)	$20 \div 4 = 5$ $10 \times 5 \times 37 = 1850 \text{cm}^3$
Q20)	39
Q21)	$6 - 4 = 2$ $3 + 1 = 4$ $4 \div 2 = 2$ $2 \times 4 = 8$ $8 + 3 = 11 \text{ sweets}$
Q22)	$72 \times 4 = 288$ $288 - 72 = 216$ $216 - 65 = 151$ $151 - 80 = 71 \text{ marks}$
Q23)	$36 \div 4 = 9$ $8 \div 2 = 4$ $10 \div 0.50 = 20$ $9 + 4 + 20 = 33$
Q24)	$\frac{1}{2} \times \frac{22}{7} \times 14 = \frac{22}{7} \times 7 = 22$ $22 + 14 + 14 = 22 + 28 = 50 \text{ cm}$
Q25)	$100 - 20 = 80 \text{ (Raj)}$ $80 : 60$ $100 - 40 = 60 \text{ (Salim)}$ $4 : 3$ $100 : 75 \text{m}$
Q26)	

Q27)	$77 \div 4 = 19R1$ $19 \times 1 = 19$ $19 + 1 = 20 \text{ men}$															
Q28)	$4U + 32 = 7U + 20$ $3U = 32 - 20 = 12$ $1U = 12 \div 3 = 4$ $7U = 7 \times 4 = 28$ $28 + 20 = 48 \text{cookies}$															
Q29)	$220^\circ + 60^\circ = 280^\circ$ $360^\circ - 280^\circ = 80^\circ$ $180^\circ - 80^\circ - 100^\circ$ $100^\circ \div 2 = 50^\circ$															
Q30)	<table style="width: 100%; border-collapse: collapse;"> <tr> <td style="width: 30%;"><u>Alynn</u></td> <td style="width: 30%;"><u>Rachel</u></td> <td></td> </tr> <tr> <td>90</td> <td>10</td> <td>$10U + 90 = (10U + 30) \times 2$</td> </tr> <tr> <td>10U</td> <td>10U + 20</td> <td>$= 10U + 90 = 20U + 60$</td> </tr> <tr> <td></td> <td></td> <td>$= 10U = 90 - 60 = 30$</td> </tr> <tr> <td></td> <td></td> <td>$1U = 30 \div 10 = \\$3$</td> </tr> </table>	<u>Alynn</u>	<u>Rachel</u>		90	10	$10U + 90 = (10U + 30) \times 2$	10U	10U + 20	$= 10U + 90 = 20U + 60$			$= 10U = 90 - 60 = 30$			$1U = 30 \div 10 = \$3$
<u>Alynn</u>	<u>Rachel</u>															
90	10	$10U + 90 = (10U + 30) \times 2$														
10U	10U + 20	$= 10U + 90 = 20U + 60$														
		$= 10U = 90 - 60 = 30$														
		$1U = 30 \div 10 = \$3$														

PAPER 2

Q1)	Joel ---6p Amanda---12p Raju --- 12p - 8 $6p + 12p + 12p - 8 = (30p - 8) \text{ marbles}$
Q2)	$25u = 325$ $1u = 325 \div 25 = 13$ $5u = 13 \times 5 = 65 \text{ sweets}$
Q3)	$6u = 78$ $1u = 78 \div 6 = 13 \text{ cm}^2$
Q4)	a)False b)True
Q5)	$38 - 18 = 20$ 5 mins --- 20 10 mins--- $20 \times 2 = 40$ $58 + 40 = 98$ $98 - 38 = 60L$

Q6)	$\frac{1}{3}J = \frac{3}{5}N$ $\frac{3}{9}J = \frac{3}{5}N$ $42 \times 2 = 84$ $9u - 5u = 4u$ $4u = 84$ $1u = 84 \div 4 = 21$ $5u = 21 \times 5 = \$105$
Q7)	$45 - 37 = 8$ <p>8 pieces $\rightarrow 5.04\text{m}$</p> <p>1 piece $\rightarrow 5.04\text{m} \div 8 = 0.63\text{m}$</p> <p>45 pieces $\rightarrow 0.63\text{m} \times 45 = 28.35\text{m}$</p>
Q8)	$\frac{7}{10} \times 4000 = 2800$ $3500 - 2800 = 700$ $\frac{700}{3500} \times 100\% = 20\%$
Q9)	$60u + 600 = 80u$ $20u = 600$ $1u = 600 \div 20 = 30$ $30 \times 80 = 2400\text{m}$
Q10)	<p>a) $\angle TQS = 60^\circ - 35^\circ = 25^\circ$</p> <p>$\angle QVR = 90^\circ - 25^\circ = 65^\circ$</p> <p>$\angle PVQ = (360^\circ - 65^\circ - 65^\circ) \div 2 = 115^\circ$</p> <p>$\angle QPR = 180^\circ - 35^\circ - 115^\circ = 30^\circ$</p> <p>b) $\angle QTS = 180^\circ - 25^\circ - 60^\circ - 75^\circ = 20^\circ$</p>
Q11)	$60\% \rightarrow 324$ $10\% \rightarrow 324 \div 6 = 54$ $100\% \rightarrow 54 \times 10 = 540$ $40\% \rightarrow 54 \times 4 = 216$ $216 \div 6 = 36$ $36 \times 4 = 144$ $144 + 324 = 468$ $36 : 468 = 1 : 13$
Q12)	<p>a) $84\% \rightarrow 152880$</p> <p>$1\% \rightarrow 152880 \div 84 = 1820$</p>

	<p>100% → 1820 x 100 = 182000 (June)</p> <p>b) $\frac{12}{10} \times 152880 = 183456$ (August)</p> <p>183456 - 182000 = 1456</p> <p>$\frac{1456}{182000} \times 100\% = 0.8\%$</p>
Q13)	<p>a) 80 x 60 x 45 = 216000</p> <p>b) $33\frac{3}{4}$</p> <p><u>Tank A Tank B</u></p> <p>Base = 45 x 40 = 1800 80 x 60 = 4800</p> <p>Rate = $\frac{2700}{1800} = \frac{3 \cdot 2400}{2 \cdot 4800} = \frac{1}{2}$</p> <p>$\frac{3}{2}t = 45 - \frac{1}{2}t$</p> <p>2t = 45</p> <p>t = 22.5</p> <p>height = $\frac{3}{2}t = \frac{3}{2}(22.5)$</p> <p>= 33.75 ($33\frac{3}{4}$)</p>
Q14)	<p>a) $\angle ACB = 180^\circ - 75^\circ - 65^\circ = 40^\circ$</p> <p>$\angle FAC = 180^\circ - 65^\circ - 75^\circ = 40^\circ$</p> <p>$\angle AFC = 180^\circ - 40^\circ - 30^\circ = 110^\circ$</p> <p>$\angle CFE = 180^\circ - 110^\circ = 70^\circ$</p> <p>b) $\angle FED = 180^\circ - 40^\circ = 140^\circ$</p>
Q15)	<p>288 ÷ 12 = 24</p> <p>324 ÷ 12 = 27</p> <p>27 x 24 = 648</p> <p>648 ÷ 4 x 3 = 486 pieces</p>
Q16)	<p>a) 760 b) 400</p> <p>A = u + 200 → $\frac{3}{4}y + 170$ $\frac{5}{7} \times 560 = 400$</p> <p>P = u → $\frac{5}{7}y$</p> <p>$\frac{3}{4}(u + 200) = y + 170$</p> <p>$\frac{5}{7}u = y$</p> <p>$\frac{3}{4}u + 150 = \frac{5}{7}u + 170$</p> <p>$\frac{1}{28}u = 20$</p> <p>u = 560 + 260 = 760</p>

Q17)

a) 5:9

C : A
18 : 10
9 : 5

b) 378 boys

A : C : T
5 : 9 : 14 x 672
3360 6048 9408
 $3360 \div 5 = 672 (A)$
 $6048 \div 6 = 1008 (C)$
 $1008 = 5G \ 3B$
 $1008 \div 8 \times 3 = 378$

AT / GAL / WSW / EC

Index No.

					-	
--	--	--	--	--	---	--

SINGAPORE CHINESE GIRLS' SCHOOL

PRELIMINARY EXAMINATION 2019

PRIMARY 6

MATHEMATICS
PAPER 1

BOOKLET A

Name : _____ ()

Class : Primary 6 SY / C / G / SE / P

20 August 2019

		Marks attained	Max Mark
Paper 1	Booklet A		20
	Booklet B		25
Paper 2			55
Total Marks			100

Parent's Signature

--

15 Questions
20 Marks

Total Time for Booklets A and B: 1 h

INSTRUCTIONS TO CANDIDATES

Do not open this booklet until you are told to do so.

Follow all instructions carefully.

Answer all questions.

You are not allowed to use a calculator

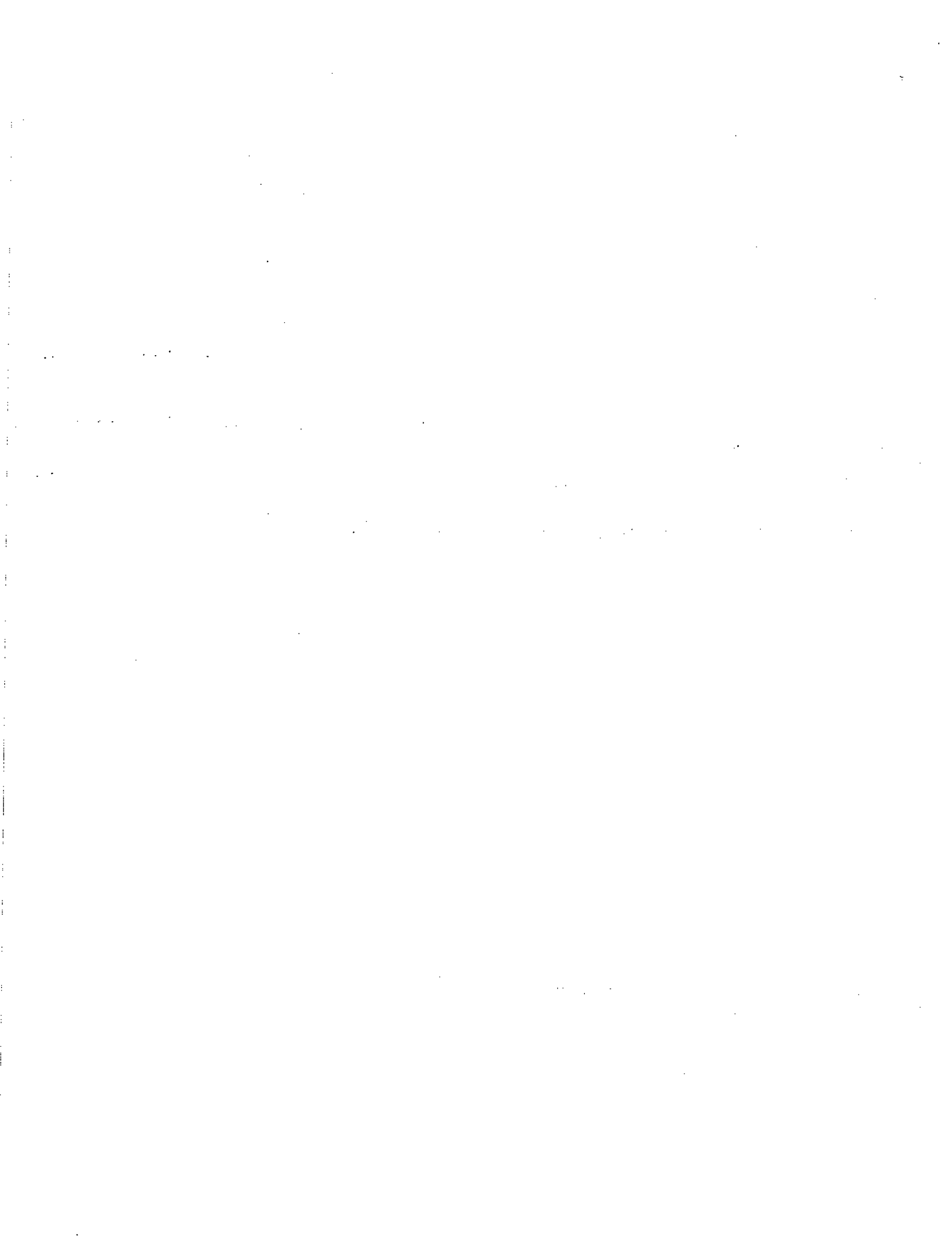

Booklet A

Questions 1 to 10 carry 1 mark each. Questions 11 to 15 carry 2 marks each.
For each question, four options are given. One of them is the correct answer.
Make your choice (1, 2, 3 or 4) and shade your answer on the Optical Answer Sheet.
(20 marks)

1. What does the digit 3 in 4.362 stand for?

- (1) 3 ones
- (2) 3 tenths
- (3) 3 hundredths
- (4) 3 thousandths

2. Express 10.85 km in metres.

- (1) 108.5 m
- (2) 1085 m
- (3) 10 850 m
- (4) 108 500 m

3. Which of the following, when rounded off to the nearest thousands, is not 27 000?

- (1) 26 749
- (2) 26 952
- (3) 27 308
- (4) 27 514

4. Which of the following statements is true about the parallelogram ABCD?

- (1) $\angle DAB + \angle BCD = 180^\circ$
- (2) AD is perpendicular to BC.
- (3) A parallelogram has a line of symmetry
- (4) $\angle ABC = \angle ADC$.

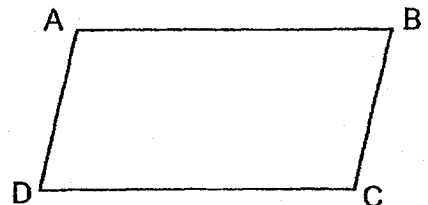

5. Which of the following fractions has the smallest value?

(1) $\frac{5}{11}$

(2) $\frac{4}{7}$

(3) $\frac{1}{2}$

(4) $\frac{7}{9}$

6. Find the value of $55 + \frac{5}{100} + \frac{5}{1000}$.

(1) 55.505

(2) 55.55

(3) 55.05

(4) 55.055

7. Which of the following is not a net of a prism?

(1)

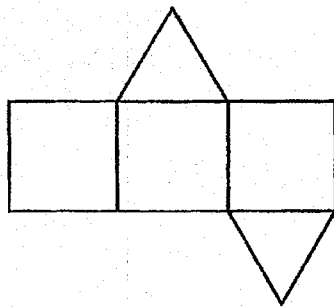

(2)

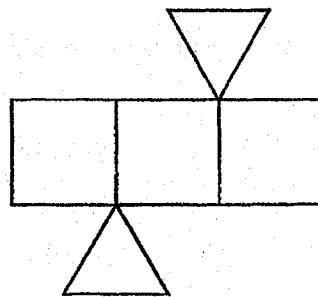

(3)

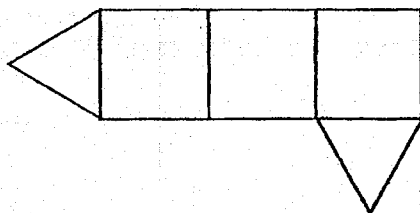

(4)

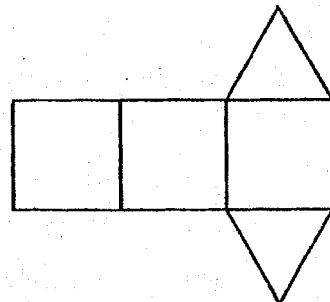

8. Which of the following letters has only one line of symmetry?

- (1) E
- (2) H
- (3) O
- (4) X

E H O X

9. In the square grid below, A, B, C and D represent four landmarks in a town. In which direction is C from D?

- (1) N
- (2) W
- (3) NW
- (4) SE

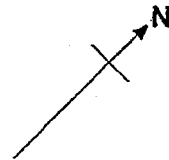
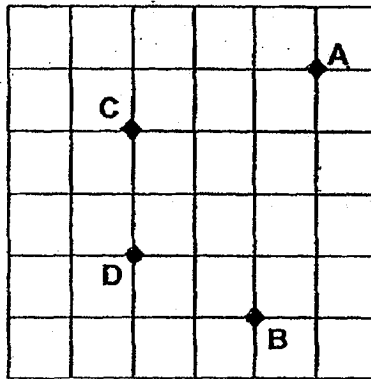

10. Nurul saved a total of \$3.00 in three days. Each day, she saved 30 cents more than the previous day. How much did she save on the second day?

- (1) \$1.00
- (2) \$0.70
- (3) \$1.10
- (4) \$0.80

11. The pie chart shows the favourite fruit of a group of children. 150 children like cherry and mango. How many more children prefer cherry to mango?

- (1) 90
- (2) 60
- (3) 30
- (4) 15

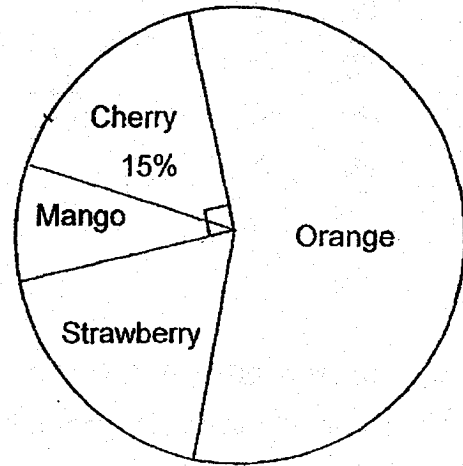

12. The figure below is made up of two identical quadrants and a square. What is the perimeter of the shaded part?

- (1) $(5\pi + 10)$ cm
- (2) $(5\pi + 20)$ cm
- (3) $(20\pi + 10)$ cm
- (4) $(20\pi + 20)$ cm

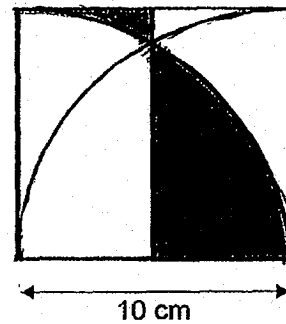

13. In the figure below, ABCD is a square. $\angle DAE = 39^\circ$ and $\angle AGD = 47^\circ$. Find $\angle AFD$.

- (1) 41°
- (2) 45°
- (3) 47°
- (4) 51°

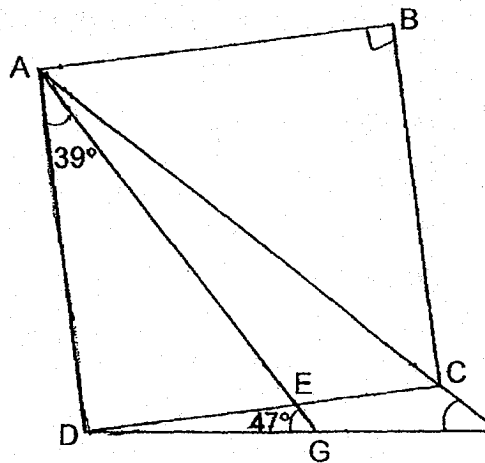

14. The table below shows the NAPFA test Awards of a group of students.

Award	Number of students
Gold	80
Silver	70
Bronze	40
Nil	?

$\frac{3}{4}$ of the students achieved at least a Silver award in the NAPFA test. How many students did not achieve any award?

- (1) 10
(2) 30
(3) 40
(4) 50
15. A cyclist took $\frac{3}{10}$ h to cycle from his home to the park, 12 km away. When he left the park, he cycled along the same route and took 30 min to reach home. What was his average speed for the whole journey to and fro?
- (1) 15 km/h
(2) 30 km/h
(3) 48 km/h
(4) 64 km/h

(Go on to Booklet B)

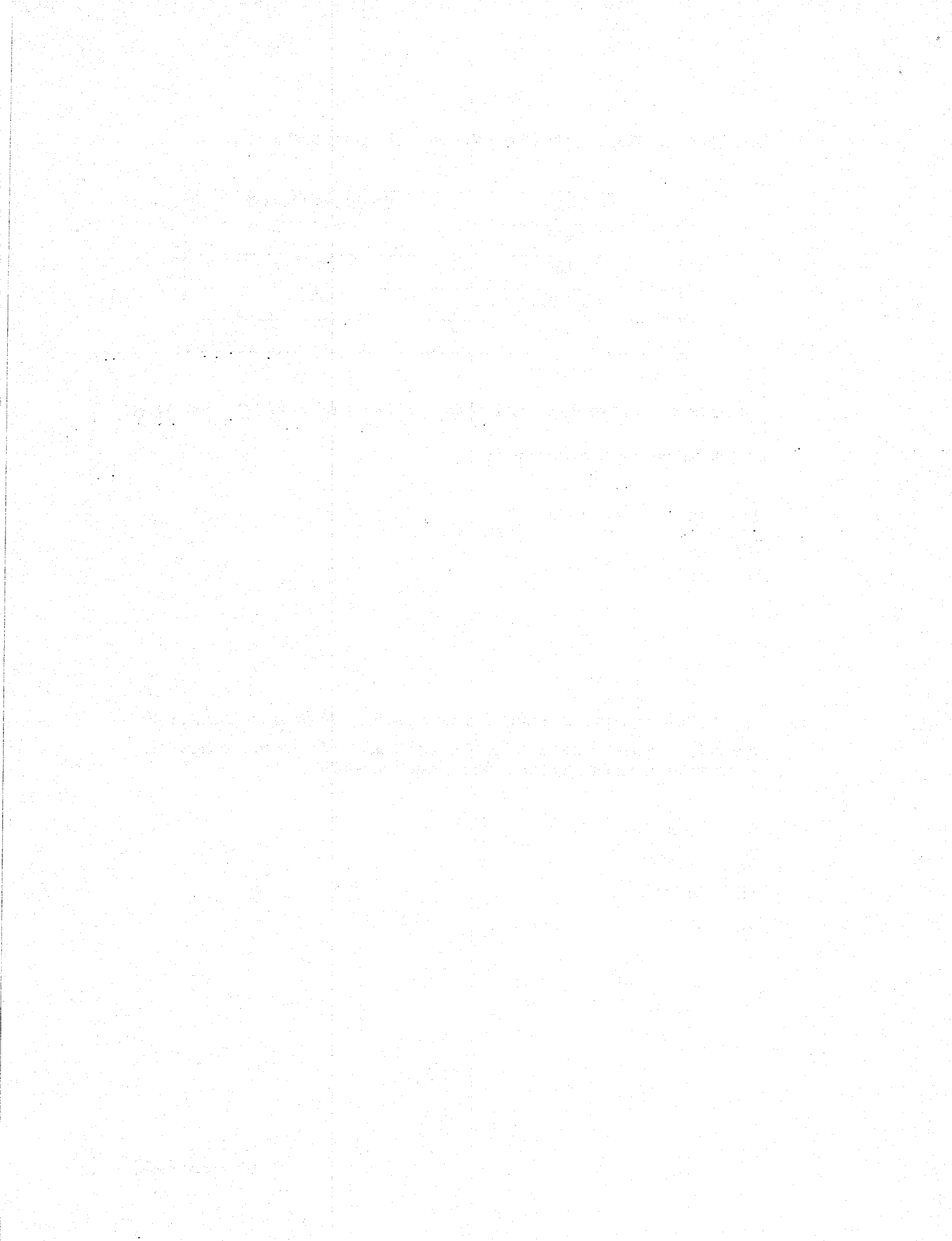

Index No. -

SINGAPORE CHINESE GIRLS' SCHOOL

PRELIMINARY EXAMINATION 2019

PRIMARY 6

**MATHEMATICS
PAPER 1**

BOOKLET B

Name : _____ ()

Class : Primary 6 SY / C / G / SE / P

20 August 2019

Paper 1	Mark attained	Max Mark
Booklet B		25

15 Questions

25 Marks

Total Time for Booklets A and B: 1 h

INSTRUCTIONS TO CANDIDATES

Do not open this booklet until you are told to do so.

Follow all instructions carefully.

Answer all questions.

You are **not allowed** to use a calculator

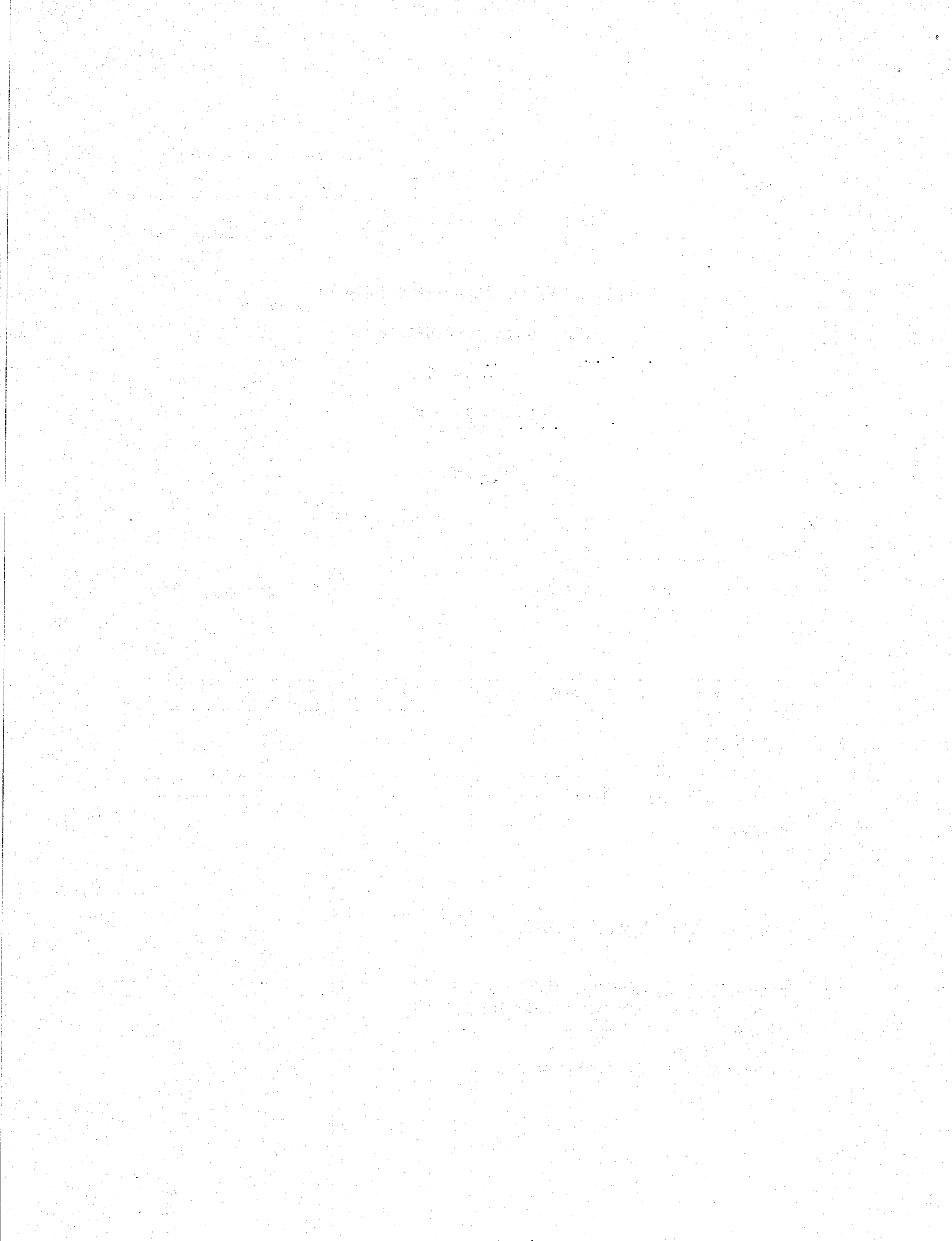

Booklet B

Questions 16 to 20 carry 1 mark each. Write your answers in the spaces provided. For questions which require units, give your answers in the units stated. (5 marks)

Do not write
in this
column

16. Evaluate $\frac{2}{3} \times (48 - 30) + 28 \div 4$

Ans: _____

17. Find the value of $\frac{5}{6} \div 10$.

Ans: _____

18. What is the length of the paper clip?

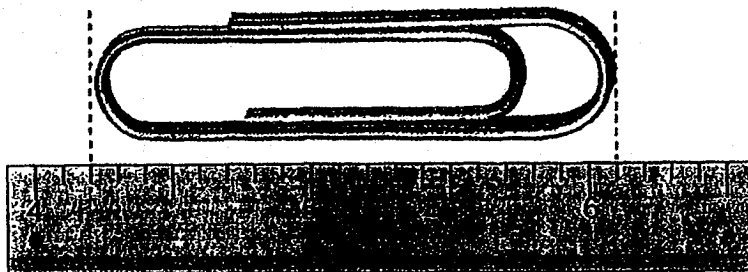

Ans: _____ cm

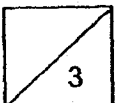

19. Express 0.429 as a percentage.

Do not write
in this
column

Ans: _____ %

20. Brandon used a piece of 68-cm wire to fold into a star, such that $AC = CE = EB = BD = DA$. What is the length of AC?

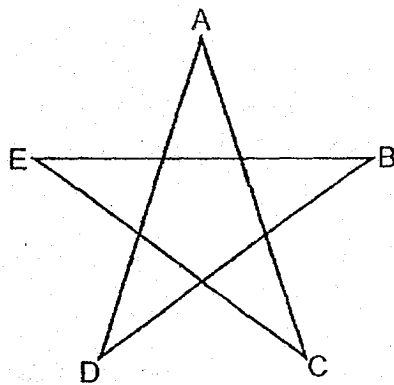

Ans: _____ cm

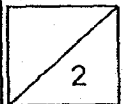

Questions 21 to 30 carry 2 marks each. Show your working clearly in the space for each question and write your answers in the space provided. For questions which require units, give your answers in the units stated. (20 marks)

Do not write
in this
column

21. A triangle C is drawn by joining dots on the square grid with three straight lines.
- (a) In the same way, draw another triangle with twice the perimeter of C on the square grid. Label this triangle D.
- (b) What is the ratio of the area of C to the area of D?

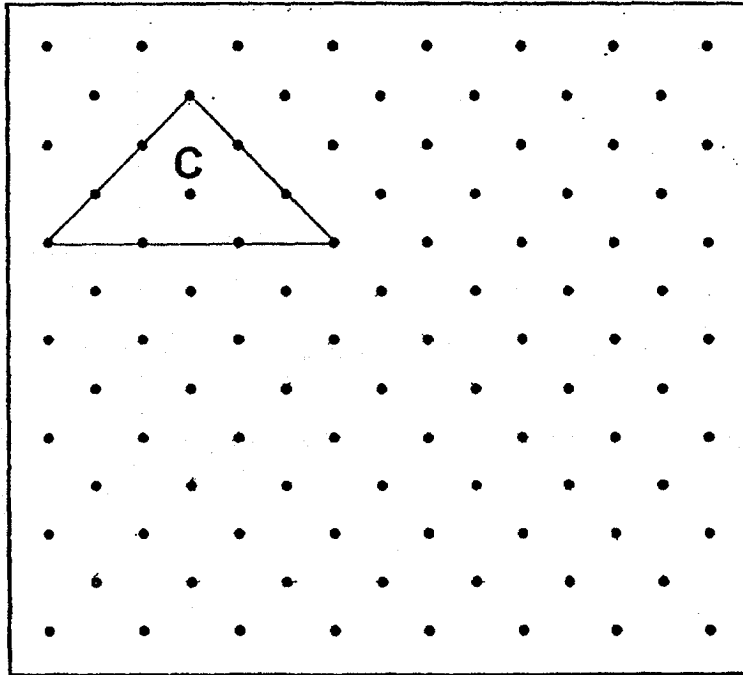

Ans: b) _____

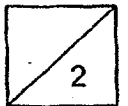

22. The figure below is made up of three 2-cm cubes. Find the total surface area of the figure.

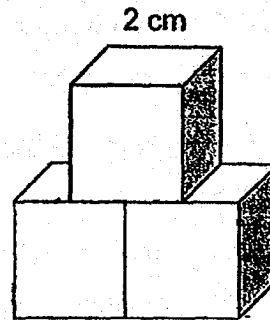

Do not write
in this
column

Ans: _____ cm²

23. Peggy saved $\frac{2}{7}$ of her salary and Gary saved $\frac{4}{9}$ of his salary. If they saved the same amount of money, what is the ratio of Peggy's salary to Gary's salary?

Ans: _____

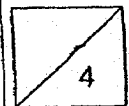

Use the information below to answer Questions ²⁴~~23~~ and ²⁵~~24~~.

Do not write
in this
column

The graph below shows the number of children who participated in an art competition in the respective years.

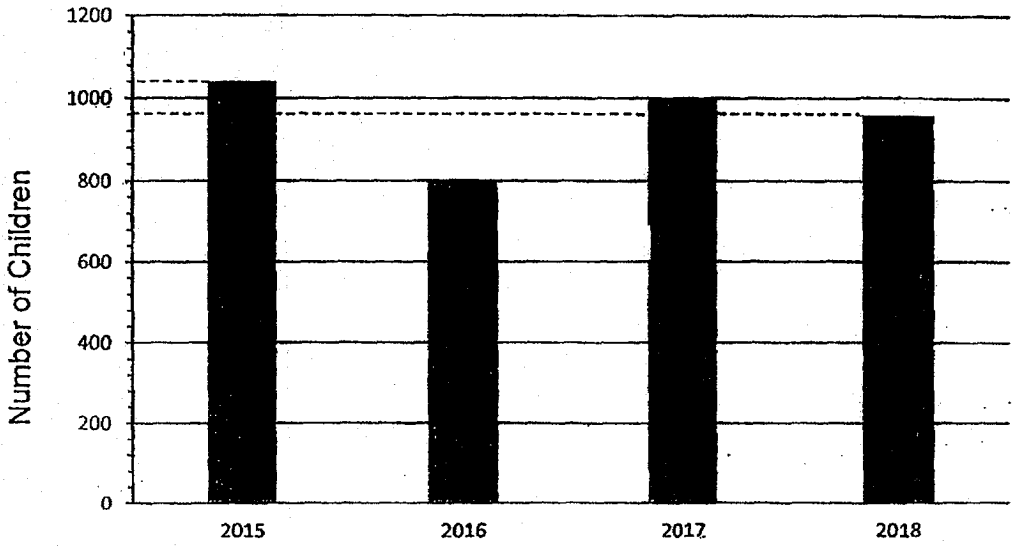

24. What is the percentage increase in the number of participants between the years 2016 and 2017?

Ans: _____ %

25. What is the average number of students who participated in the competition?

Ans: _____

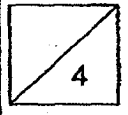

26. ABCD is a square with an area of 108 cm^2 . E is the midpoint of BC and F is the midpoint of AB. Find the shaded area.

Do not write
in this
column

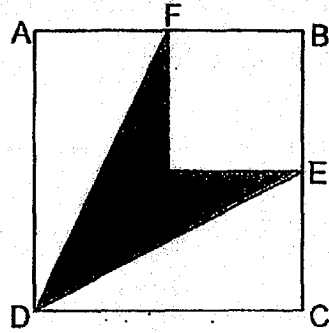

Ans: _____ cm^2

27. Sandra is p years old. Jay is 3 years older than her and 5 years younger than Erin. What is the total age of the three children?

Ans: _____

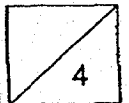

28. The table below shows the number of hours that a group of 20 children spent on screen time in a day.

Do not write
in this
column

Number of hours spent	0	2	3	4
Number of children	2	7	8	3

What is the average number of hours spent on screen time each day?

Ans: _____ hours

29. The following figure is made up of 4 identical rectangles and a shaded rectangle. The length of BC is 16 cm. If the area of the shaded part is 24 cm^2 , what is the length of EB?

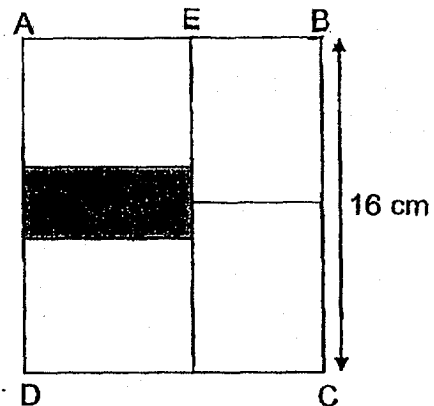

Ans: _____ cm

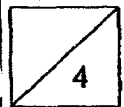

30. The figure below is not drawn to scale. It is made up of an isosceles triangle and a rhombus. $\angle MRN = 57^\circ$ and $\angle NPQ = 122^\circ$.

Do not write
in this
column

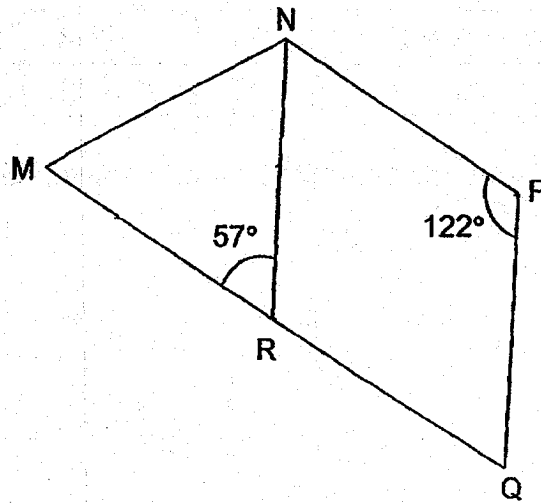

Each of the statements below is either true, false or not possible to tell from the information given. For each statement, put a tick (✓) to indicate your answer.

Statement	True	False	Not possible to tell
The lines MR and RN are equal in length.			
The figure MNPQR is a trapezium.			

End of Booklet B

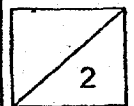

BLANK PAGE

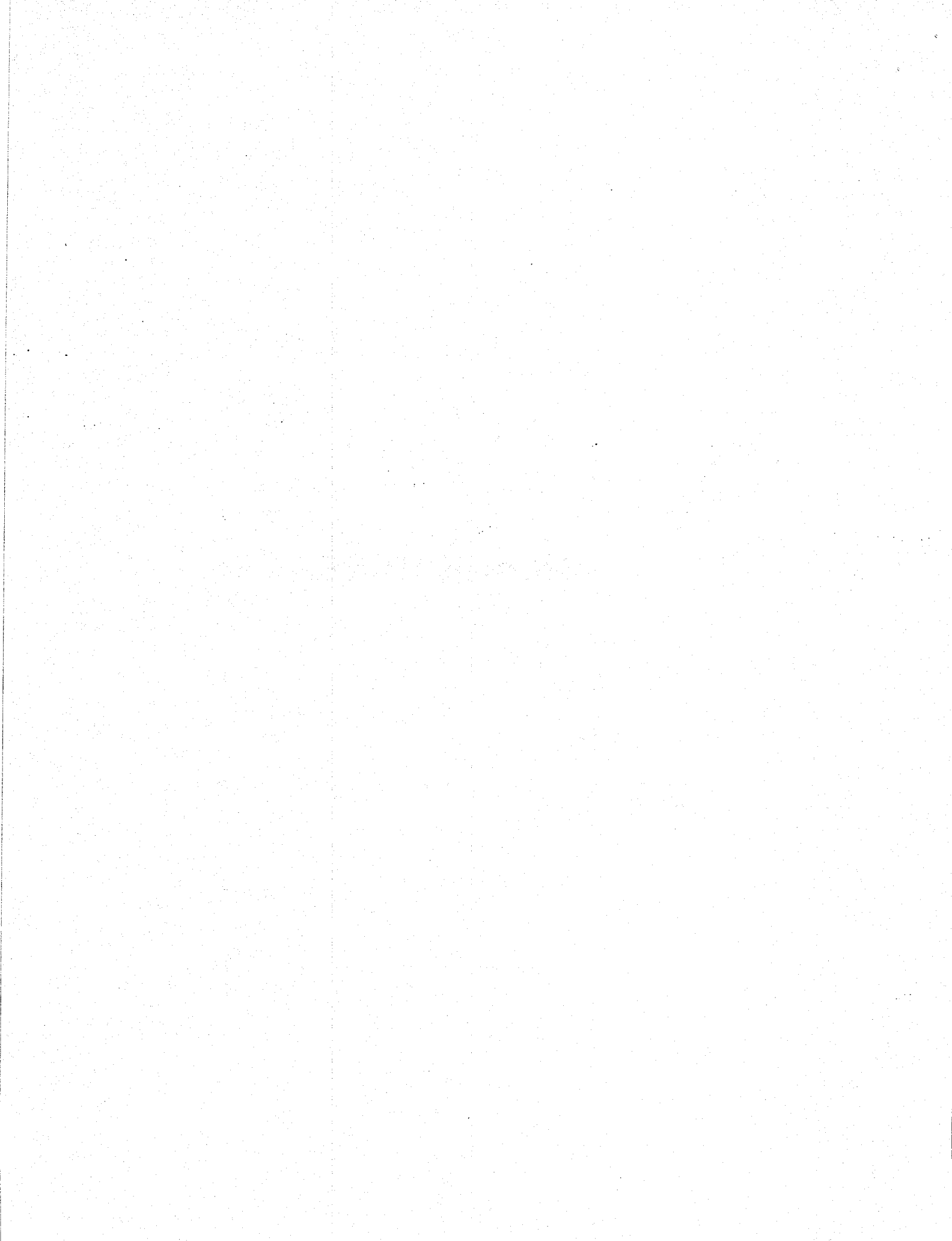

Index No.

--	--	--	--	--

 -

--

SINGAPORE CHINESE GIRLS' SCHOOL

PRELIMINARY EXAMINATION 2019

PRIMARY 6

MATHEMATICS

PAPER 2

Name : _____ ()

Class : Primary 6 SY / C / G / SE / P

20 August 2019

	Mark	Max Mark
Paper 2		55

Parent's Signature

17 Questions
55 Marks

Total Time for Paper 2: 1 h 30 min

INSTRUCTIONS TO CANDIDATES

Do not open this booklet until you are told to do so.

Follow all instructions carefully.

Answer all questions.

You **are allowed** to use the calculator

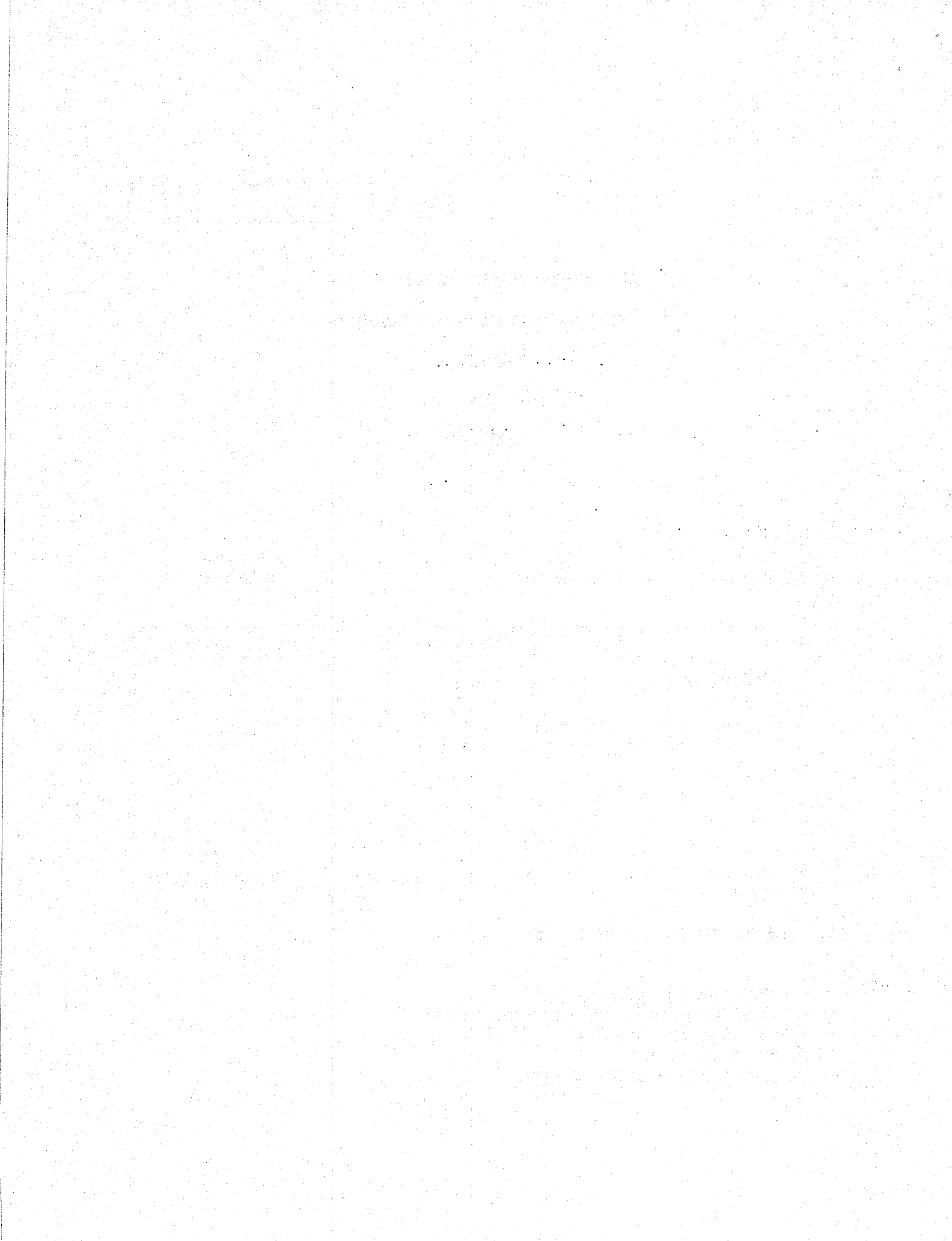

Questions 1 to 5 carry 2 marks each. Show your working clearly in the space below each question and write your answers in the spaces provided. For questions which require units, give your answers in the units stated. (10 marks)

Do not write in this column

- 1 Peter wanted to buy a bag but he only had $\frac{1}{5}$ of the money. After receiving \$12 from his father, he was still short of $\frac{1}{2}$ of the money. What is the price of the bag?

Ans: \$ _____

-
- 2 Alan, Ben and Carol had 18, 27 and 106 marbles respectively. Each of them bought an equal number of marbles, after which Carol had as many marbles as the total number that Alan and Ben had. How many marbles did each child buy?

Ans: _____

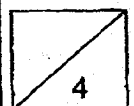

3. Roger saves \$y on Monday. Every day, he increases the amount saved by 100%. Find the total amount saved from Monday to Wednesday.

Do not write in
this column

Ans: \$ _____

-
4. A tin of paint weighed 10.5 kg when it was $\frac{1}{2}$ full. When it was $\frac{1}{3}$ full, it weighed 7.5 kg. What was the mass of the tin when it was empty?

Ans: _____ kg

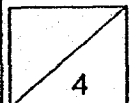

5. Mr Wong gave away 236 apples to a group of people. There were 10 more children than adults who received the apples. Each child received 2 apples while each adult received 4. How many adults received the apples?

Do not write in
this column

Ans: _____

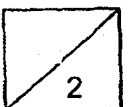

For questions 6 to 17, show your working clearly in the space below each question and write your answers in the spaces provided. The number of marks awarded is shown in brackets [] at the end of each question or part-question. (45 marks)

Do not write in this column

6. A notebook cost \$2. For every 4 notebooks bought, 1 was given free. Hoping to enjoy the promotion, Jane wanted to buy 18 notebooks but is short of \$3. How much money does she have?

Ans: _____ [3]

7. In the figure, JKLM is a square, $\angle MNK = 156^\circ$. Find $\angle JKN$.

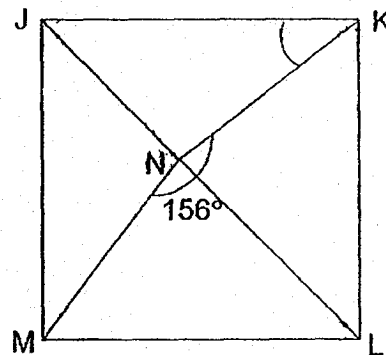

Ans: _____ [3]

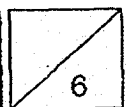

8. Town P and Town Q are 221 km apart. Laura left Town P for Town Q at 10.00 a.m., travelling at an average speed of 81 km/h. Mandy left Town Q for Town P at 11.00 a.m., travelling at an average speed of 94 km/h. What was the distance travelled by Laura when she passed Mandy?

Do not write in this column

Ans: _____ [3]

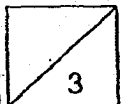

9. The figure below is made up of two semi-circles and two isosceles triangles. The diameter of the smaller semi-circle is 10 cm while the diameter of the bigger semi-circle is 15 cm.

Taking $\pi = 3.14$, find the area of the shaded part.

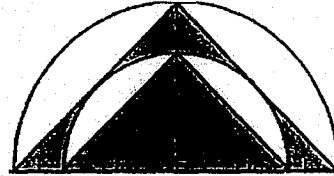

Do not write in
this column

Ans: _____ [3]

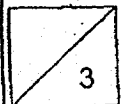

10. Figure A shows a sealed container partially filled with 48 cm^3 of water. The container is then placed lying on its back as shown in Figure B. What is the height of the water level in Figure B?

Do not write in this column

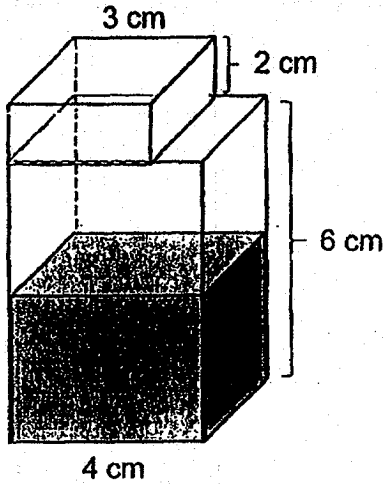

Figure A

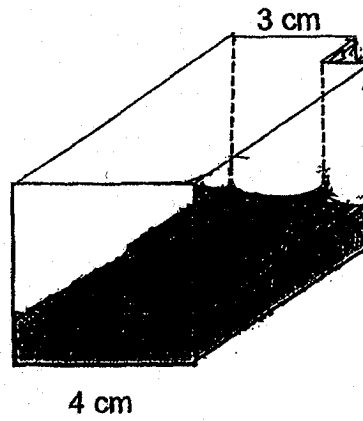
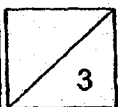

Figure B

Ans: _____ [3]



11. Mrs Teo paid \$122.40, after 15% discount, for petrol purchase at a petrol station. Petrol price before discount was \$2.25 per litre.

Do not write in
this column

- (a) How many litres of petrol did Mrs Teo purchase?
- (b) Mrs Teo's car can travel 15.8 km with every litre of petrol. With the amount of petrol that she had purchased, what is the maximum distance that her car can travel?

Ans: a) _____ [2]

b) _____ [2]

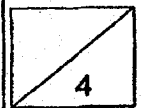

12. The figure below is not drawn to scale. ABCD is a rhombus and BCE is an equilateral triangle. $\angle ADC = 64^\circ$. Find $\angle CAE$.

Do not write in
this column

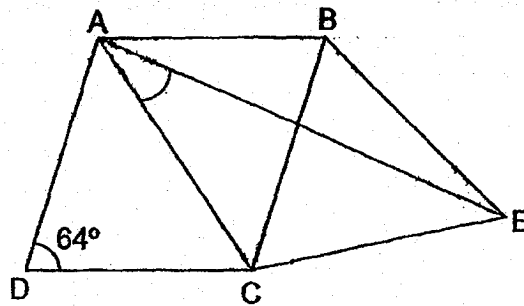

Ans: _____ [4]

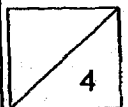

13. Pauline had some money. She spent $\frac{1}{4}$ of it on a book and received another \$33 from her mother. With what she had left, she spent 60% of it on a bag and had \$24 left. How much money did Pauline have at first?

Do not write in
this column

Ans: _____ [4]

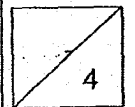

14. A piece of square paper of sides 12 cm is cut into 4 parts W, X, Y and Z along the dotted lines as shown below. The 4 pieces of cutouts can be rearranged to form a rectangle by shifting Z and W.

Do not write in this column

- (a) What is the area of the rectangle?
- (b) Find the perimeter of the rectangle that is formed.

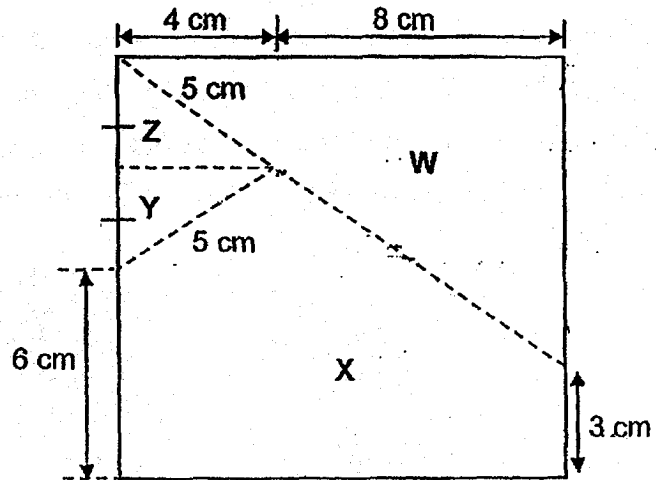

Ans: a) _____ [2]

b) _____ [2]

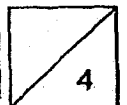

15. The table shows the overseas postage rate for bulky items.

Destinations	1 st 5kg	Additional kg or part thereof
Australia	\$40	\$7
Europe	\$50	\$9
Korea	\$30	\$5

Do not write in this column

Timothy sent a parcel to each of his friends in Australia, Europe and Korea as shown below. Timothy paid a total of \$148 for the postage of the three parcels. He paid \$16 more for the postage to Australia than to Korea. What was the additional mass that Timothy was charged for the postage to Australia?



To Europe
Parcel weighs less than 5 kg



To Korea
Parcel weighs more than 5 kg

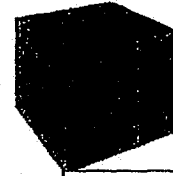

To Australia
Parcel weighs more than 5 kg

Ans: _____ [4]

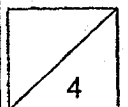

16. The diagram shows three banners hung from a beam to the floor. The total length of the three banners is 8.7 m. Banner B is 4.2 m long.

Banner A and Banner C are each extended with a rope, after which each extended banner reaches the floor like Banner B. The longer rope is twice the length of the shorter rope.

What is the length of Banner C?

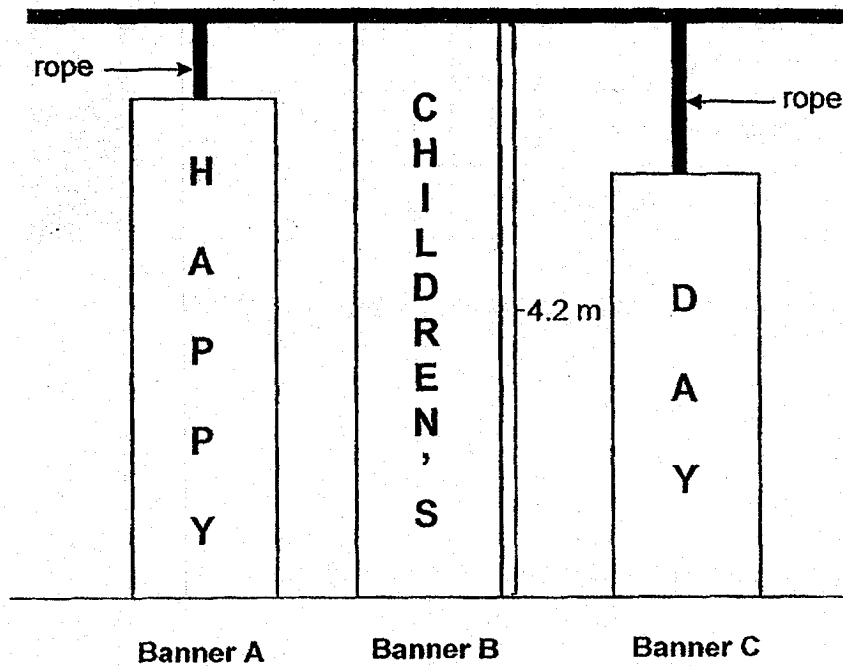

Do not write
this column

Ans: _____ [5]

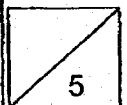

17. Study the pattern carefully and answer the questions that follow.

Do not write in this column

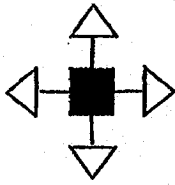

Pattern 1

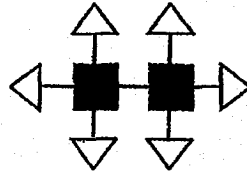

Pattern 2

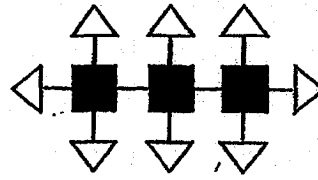

Pattern 3

Pattern number	1	2	3	...	25
Number of triangles	4	6	8	...	
Number of straight lines	4	7	10	...	

- (a) How many triangles are needed to form Pattern 25?
- (b) Which pattern is made up of 217 straight lines?
- (c) What is the total number of triangles and squares needed to form Pattern 48?

Ans: a) _____ [1]

b) _____ [2]

c) _____ [2]

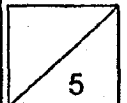

End of Paper

BLANK PAGE

SCHOOL : SCGS PRIMARY SCHOOL
 LEVEL : PRIMARY 6
 SUBJECT : MATH
 TERM : 2019 PRELIM

PAPER 1 BOOKLET A

Q 1	Q2	Q3	Q4	Q5	Q6	Q7	Q8	Q9	Q10
2	3	4	4	1	4	3	1	3	1

Q 11	Q12	Q13	Q14	Q15
3	2	1	1	2

PAPER 1 BOOKLET B

Q16)	$\frac{2}{3} \times 18 + 28 \div 4$ $= \frac{2}{3} \times 18 + 7$ $= 12 + 7 = 19$
Q17)	$\frac{5}{6} \div 10 = \frac{5}{6} \times \frac{1}{10} = \frac{1}{12}$
Q18)	$6.1 - 4.2 = 1.9 \text{ cm}$
Q19)	$0.429 \times 100\% = 42.9\%$
Q20)	$68 \div 5 = 13.6 \text{ cm}$
Q21) a)	

	b) C : D 4.5 : 18 = 1 : 4						
Q22)	$8 + 1 + 5 = 14$ $14 \times 4 = 56\text{cm}^2$						
Q23)	$\frac{2}{7} \times 2 = \frac{4}{14}$ P : G 14 : 9						
Q24)	$1000 - 800 = 200$ $\frac{200}{800} \times 100 = 25\%$						
Q25)	$1040 + 1000 + 960 + 800 = 3800$ $3800 \div 4 = 950$						
Q26)	$108 \div 4 = 27$ $108 - 27 = 81$ $108 \div 2 = 54$ $81 - 54 = 27\text{cm}^2$						
Q27)	(P X 3) + 3 + 3 +5 =3P +11						
Q28)	$(7 \times 2) + (8 \times 3) + (3 \times 4)$ $= 14 + 24 + 12$ $= 50 \div 20 = 2.5 = 2\frac{1}{2}$ HOURS						
Q29)	$16 \div 2 = 8$ $24 \div 8 = 3$ $(16 - 3) \div 2 = 6.5\text{cm}$						
Q30)	<table border="1" style="margin-left: 20px;"> <tr> <td style="width: 50px; height: 20px;"></td> <td style="width: 50px; height: 20px;"></td> <td style="width: 50px; height: 20px; text-align: center;">✓</td> </tr> <tr> <td style="width: 50px; height: 20px;"></td> <td style="width: 50px; height: 20px; text-align: center;">✓</td> <td style="width: 50px; height: 20px;"></td> </tr> </table>			✓		✓	
		✓					
	✓						

PAPER 2

Q1)	$5 - 2 = 3$ $3u \rightarrow 12$ $1u \rightarrow 12 \div 3 = 4$ $4x (5x2) = 40$
Q2)	$18 + 27 = 45$ $2u + 45 = 1u + 106$ $1u \rightarrow 106 - 45 = 61$
Q3)	$\$y \times 2 = \$2y$ $\$2y \times 2 = \$4y$ $\$4y + \$2y + \$y = \$7y$
Q4)	$\frac{1}{2} \rightarrow 10.5\text{kg}$

	$\frac{1}{3} \rightarrow 7.5\text{kg}$ $7.5\text{kg} \times 3 = 22.5\text{kg}$ $10.5\text{kg} \times 2 = 21\text{kg}$ $22.5\text{kg} - 21\text{kg} = 1.5\text{kg}$
Q5)	Diff $\rightarrow 10 \times 2 = 20$ $256 - 20 = 216$ sets $\rightarrow 216 \div (4+2) = 36$ Adults $\rightarrow 36 \times 1 = 36$
Q6)	$5\text{nb} \rightarrow \$2 \times 4 = \8 $5 \times 3 = 15\text{nb}$ $8 \times 3 = 24$ $18 - 15 = 3$ $3 \times 2 = 6$ $18\text{nb} \rightarrow 24 + 6 = 30$ $30 - 3 = \$27$
Q7)	$204^\circ \div 2 = 102^\circ$ $180^\circ - 102^\circ - 45^\circ = 33^\circ$
Q8)	$11 - 10 = 1$ $81 \times 1 = 81$ $221 - 81 = 140$ $81 + 94 = 175$ $140 \div 175 = \frac{4}{5}$ $\frac{4}{5} \times 81 = 64.8$ $64.8 + 81 = 145.8$
Q9)	$\frac{1}{2} \times 15 \times 7.5 - \frac{1}{2} \times 3.14 \times 5 \times 5$ $= 56.25 - 39.25 = 17\text{cm}^2$ Total shaded $\rightarrow 17 + (\frac{1}{2} \times 10 \times 5)$ $= 17 + 25 = 42\text{cm}^2$
Q10)	$48 \div 6 \div 4 = 2$ $(3 \times 2) + (6 \times 4) = 30$ $48 \div 30 = 1.6\text{cm}$
Q11)	a) $\frac{85}{100} \times 2.25 = 1.9125$ $122.40 \div 1.9125 = 64\text{L}$ b) $64 \times 15.8 = 1011.2\text{km}$

Q12)	$(180^\circ - 64^\circ) \div 2 = 58^\circ$ $180^\circ - 64^\circ - 60^\circ = 56^\circ$ $56^\circ \div 2 = 28^\circ$ $58^\circ - 28^\circ = 30^\circ$
Q13)	$(24 \div 2) \times 5 = 60$ $(60 - 33) \div 3 = 9$ $9 \times 4 = \$36$
Q14)	a) $12 \times 12 = 144 \text{ cm}^2$ b) $3+6+3+6+16+16 = 50\text{cm}$
Q15)	$146 - 40 - 50 - 30 = 26$ $21+5=26$ $7(x) - 5 = 16$ $7x = 21$ $X = \frac{21}{7}$ $= 3\text{kg}$
Q16)	$8.7 - 4.2 = 4.5$ $4.2 \times 2 = 8.4$ $8.4 - 4.5 = 3.9$ $(3.9 \div 3) \times 2 = 2.6$ $4.2 - 2.6 = 1.6\text{m}$
Q17)	a) $(25 \times 2) + 2 = 52$ b) $(217 - 1) \div 3 = 72$ c) $(48 \times 2) + 2 = 98$ $98 + 48 = 146$

Name: _____ ()

Class: Primary 6 _____

CHIJ ST NICHOLAS GIRLS' SCHOOL (PRIMARY)

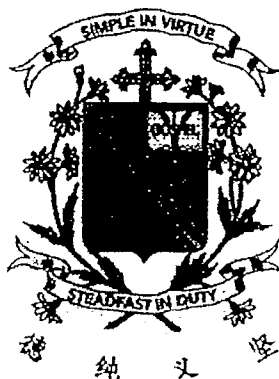

Primary 6 Mathematics
2019 Preliminary Examination

Paper 1

Booklet A

20 August 2019

15 questions
20 marks

Total Time for Booklets A and B: 1 hour

INSTRUCTIONS TO CANDIDATES

Do not turn over this page until you are told to do so.
Follow all instructions carefully.
Answer all questions.
Write your answers in this booklet.
The use of calculators is **NOT** allowed.

This booklet consists of 9 printed pages.

Questions 1 to 10 carry 1 mark each. Questions 11 to 15 carry 2 marks each. For each question, four options are given. One of them is the correct answer. Make your choice (1, 2, 3 or 4). Shade the correct oval (1, 2, 3 or 4) on the Optical Answer Sheet. (20 marks)

1. What is 90 less than 749 900?

(1) 748 810

(2) 749 810

(3) 749 910

(4) 750 800

2. What is the best estimate for 285×36 ?

(1) 200×30

(2) 200×40

(3) 300×30

(4) 300×40

3. Mr Jabir collected 30 sacks of rice for charity. He gave 7 sacks of rice to an old folks' home and another 14y sacks of rice to a children's home. How many sacks of rice did he have left?

- (1) $23 - 14y$
- (2) $23 + 14y$
- (3) $16y + 7$
- (4) $9y$

4. The line graph below shows the number of people attending a drama audition over 5 days.

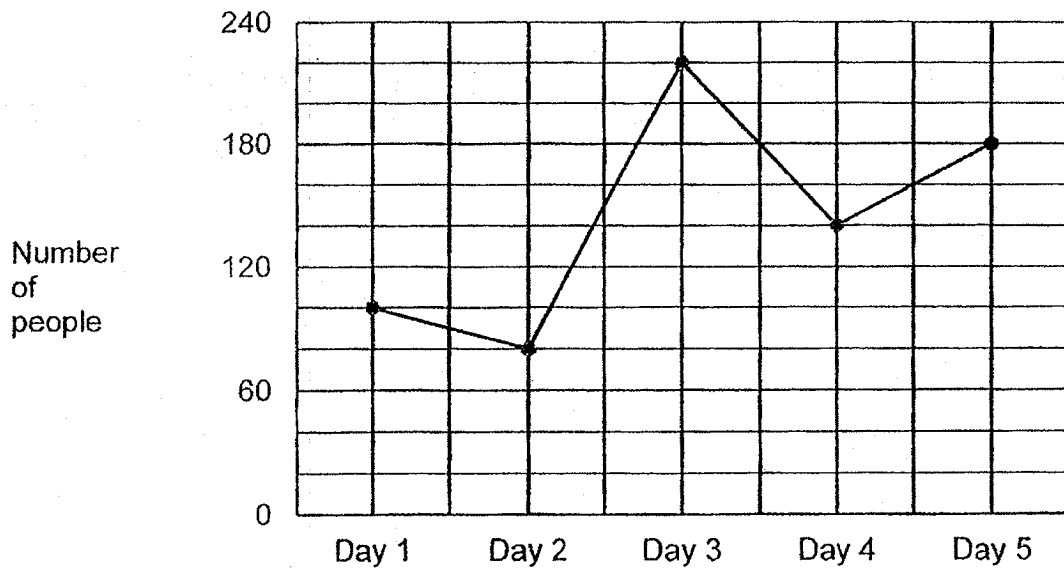

On which two days was there a difference of 40 people attending the audition?

- (1) Day 1 and Day 2
- (2) Day 2 and Day 3
- (3) Day 3 and Day 4
- (4) Day 4 and Day 5

5. In the morning, Mrs Tok sold 40 cakes. In the afternoon, she sold 50 cakes. What was the percentage increase in the number of cakes Mrs Tok sold?

- (1) 20%
- (2) 25%
- (3) 120%
- (4) 125%

6. The ratio of the number of boys to the number of girls at a carnival was 5 : 4. Which one of the following is **not** a possible total number of children at the carnival?

- (1) 153
- (2) 144
- (3) 126
- (4) 118

7. The figure below shows a cube.

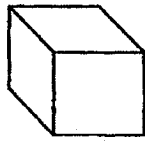

Which one of the following is a net of the cube?

(1)

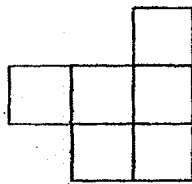

(2)

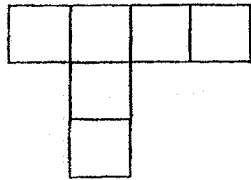

(3)

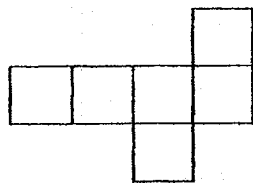

(4)

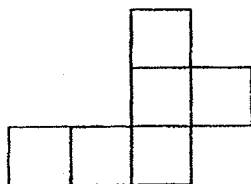

8. Arrange the following distances from the longest to the shortest.

5 km 65 m	5 km	5.15 km
-----------	------	---------

	<u>Longest</u>		<u>Shortest</u>
(1)	5.15 km	, 5 km 65 m	, 5 km
(2)	5 km 65 m	, 5 km	, 5.15 km
(3)	5 km	, 5.15 km	, 5 km 65 m
(4)	5 km	, 5 km 65 m	, 5.15 km

9. The table below shows the timings of three boys at a 100-metre race. Before the race, each of them had set a target of 12 seconds. One of the boys' timings is missing.

Name	Timing (s)
Min Shun	11.94
Xanthus	12.10
Wen Yang	?
Vijay	12.05

Min Shun was 0.12 s faster than Wen Yang. Which of the four boys' timing was the closest to the target set?

- (1) Wen Yang
- (2) Min Shun
- (3) Xanthus
- (4) Vijay

10. Hafsah walks at an average speed of 60 m/min. At this speed, how long does she take to walk 640 m?

(1) 10 min

(2) $10\frac{2}{5}$ min

(3) $10\frac{2}{3}$ min

(4) 11 min

11. A number of pupils formed a star shape with the same number of pupils on each of the sides. There were 15 pupils on each side of the star. All the sides of the star are equal. How many pupils formed the star shape?

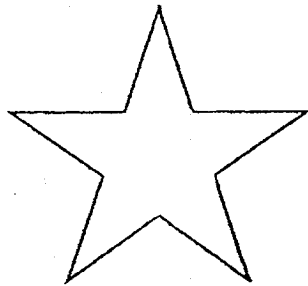

(1) 130

(2) 140

(3) 145

(4) 150

12. The figure below is made up of a square and two identical semicircles. The area of the square is 64 cm^2 . What is the area of the two semicircles? Leave your answer in terms of π .

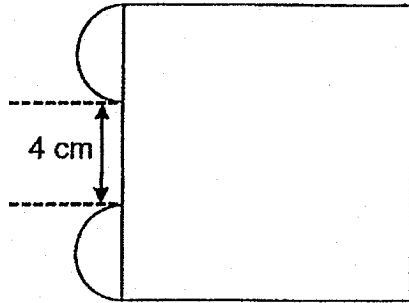

- (1) $\pi \text{ cm}^2$
 (2) $2\pi \text{ cm}^2$
 (3) $3\pi \text{ cm}^2$
 (4) $4\pi \text{ cm}^2$
13. The figure below shows a rhombus. Find $\angle y$.

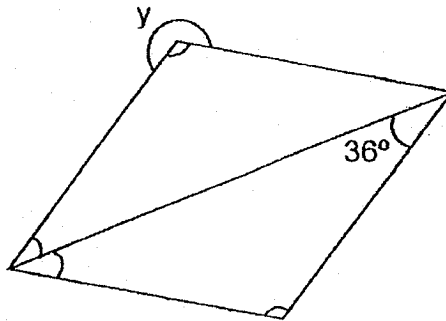

- (1) 216°
 (2) 252°
 (3) 288°
 (4) 324°

14. Cynthia followed the instructions below and ended at Point A in the end:

- (i) Walk 2 steps to the West
- (ii) Walk 1 step to the North
- (iii) Walk 2 steps to the East

At which point did she start at first?

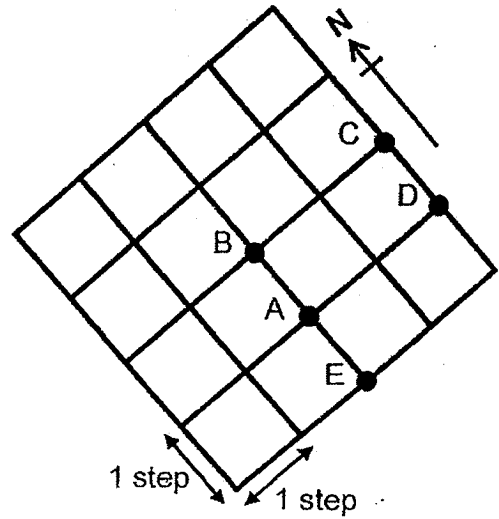

- (1) E
- (2) D
- (3) C
- (4) B

15. $\frac{1}{3}$ of the length of a table cloth is 45 cm shorter than $\frac{1}{2}$ of the length of a banner.

The total length of the table cloth and the banner is 390 cm. What is the length of the banner?

- (1) 160 cm
- (2) 183 cm
- (3) 210 cm
- (4) 237 cm

Name: _____ ()

Class: Primary 6 _____

CHIJ ST NICHOLAS GIRLS' SCHOOL (PRIMARY)



Primary 6 Mathematics
2019 Preliminary Examination

Paper 1

Booklet B

20 August 2019

Booklet A	20
Booklet B	25
Total (Paper 1)	45

15 questions
25 marks

Total Time for Booklets A and B: 1 hour

INSTRUCTIONS TO CANDIDATES

Do not turn over this page until you are told to do so.

Follow all instructions carefully.

Answer all questions.

Write your answers in this booklet.

The use of calculators is **NOT** allowed.

Questions 16 to 20 carry 1 mark each. Show your working clearly and write your answers in the spaces provided. For questions which require units, give your answers in the units stated. (5 marks)

Do not write in this space

16. Simplify $20 + 8 \times 10d \div 5 - d$.

Ans: _____

17. Write 690 thousandths as a decimal.

Ans: _____

18. Express 0.1% as a fraction.

Ans: _____

19. AD and BE are straight lines. Find $\angle a$.

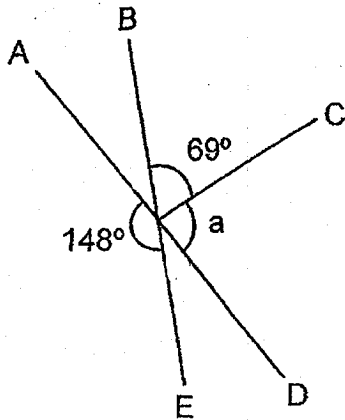

Do not
write in
this space

Ans: _____ $^\circ$

20. The container below is filled with 1700 ml of water. What is the height of the water level in the container?

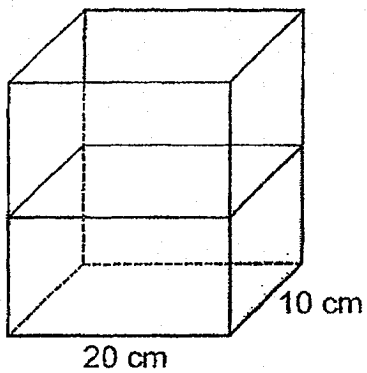

Ans: _____ cm

Questions 21 to 30 carry 2 marks each. Show your working clearly and write your answers in the spaces provided. For questions which require units, give your answers in the units stated. (20 marks)

Do not write in this space

21. Write down all the common factors of 28 and 70.

Ans : _____

22. The pie chart below shows the number of cans 4 children collected for a recycling activity. What is the ratio of the total number of cans the 4 children collected to the number of cans Flo collected? Leave your answer in the simplest form.

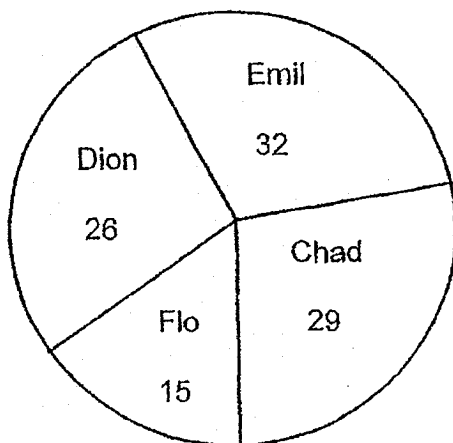

Ans : _____

23. The figure below is made up of squares. Shade four more squares to form a symmetric figure with XY as the line of symmetry.

Do not write in this space

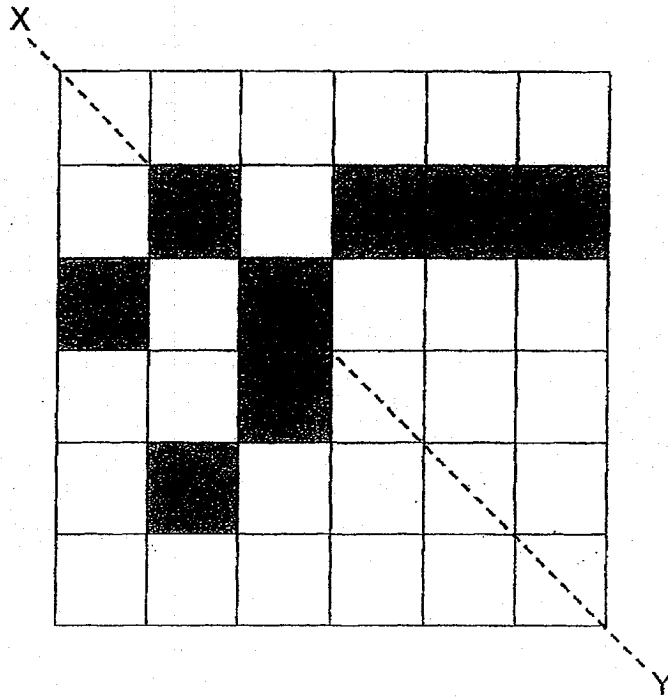

24. In the square grid below, two sides of a triangle have been drawn. Complete the drawing of triangle ABC such that CA is perpendicular to AB . Then draw another three lines to form a rectangle $ACDE$.

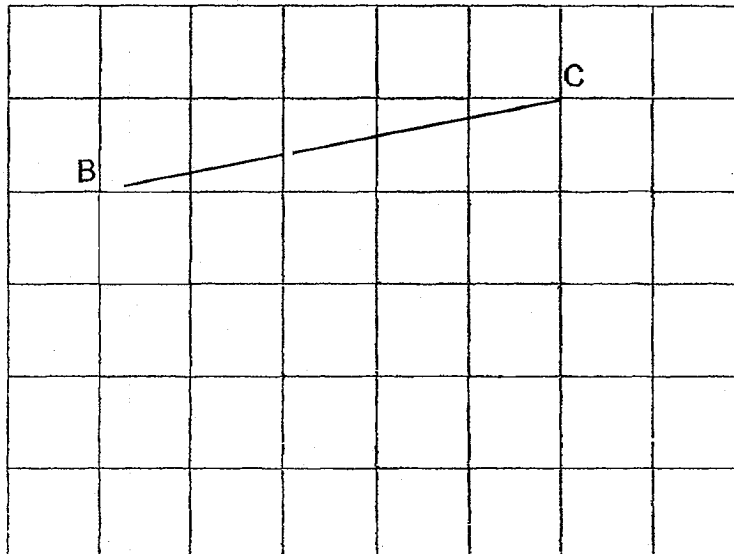

25. The graph below shows the number of staplers, rulers and calculators sold at Good Deal Bookshop.

Do not write in this space

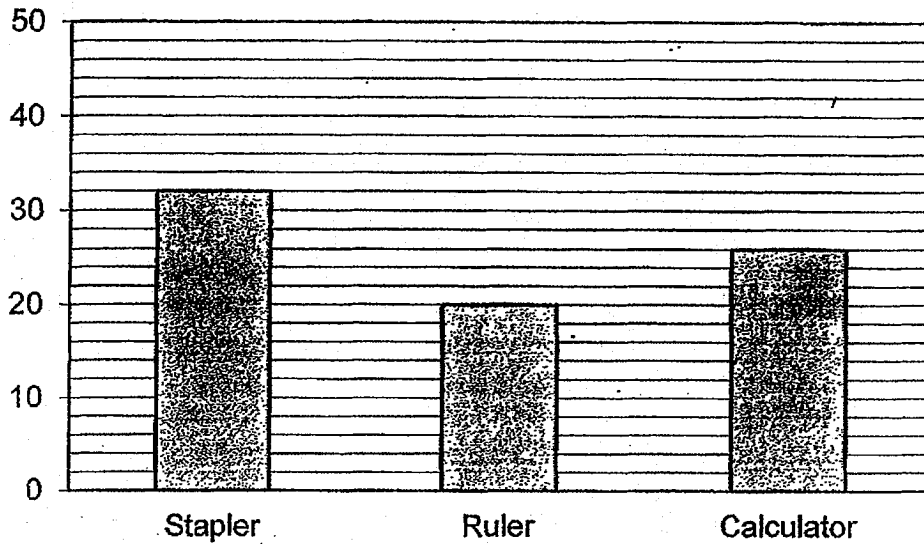

The table shows the prices of the stationery.

Type of stationery	Price per stationery
Stapler	\$2
Ruler	\$0.90
Calculator	\$30

How much more money was collected from the total sale of staplers and calculators than the sale of rulers?

Ans: \$ _____

26. The average of 4 different even numbers is 22. All the 4 numbers are 2-digit numbers. The biggest number is 26. What is the smallest possible number?

Do not
write in
this space

Ans: _____

27. A bag contained a total of 123 blue cubes, orange cubes and green cubes at first. 27 blue cubes were removed from the bag and another 39 green cubes were put into the bag. The ratio of the number of blue cubes to the number of orange cubes to the number of green cubes became 1 : 3 : 5. How many green cubes did the bag contain at first?

Ans: _____

28. The ladder beside Blake is hanging from a metal bar.
The last rung is 48 cm above the ground. What is Blake's height?

Do not
write in
this space

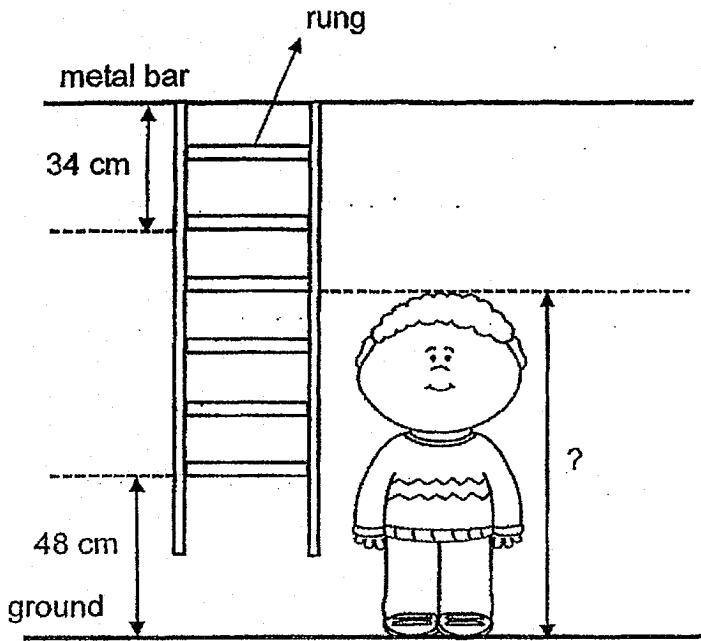

Ans: _____ m

29. The figure below is made up of a quarter circle, a triangle SVX and two equilateral triangles TVU and VXW. The perimeter of the figure is 98 cm and $TU = 14$ cm. What is the length of SX? (Take $\pi = \frac{22}{7}$)

Do not write in this space

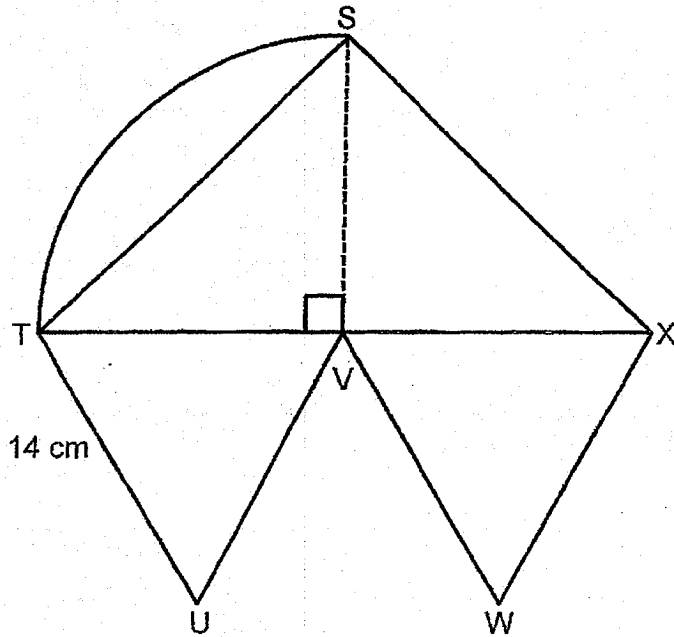

Ans: _____ cm

30. Shing Wen had some hearts and 50 sticks. He used the hearts and sticks to make three figures that follow a pattern as shown below. Then he pasted the three figures onto a cardboard.

Do not write in this space



Figure 1

1 heart
4 sticks

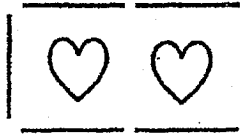

Figure 2

2 hearts
6 sticks



Figure 3

3 hearts
8 sticks

Each statement below is either True, False or Not possible to tell. For each statement, put a tick (✓) in the correct column.

Statement	True	False	Not possible to tell
Shing Wen used all the hearts he had to make the three figures.			
Shing Wen would have enough sticks to continue with the pattern to make Figure 6.			

Name: _____ ()

Class: Primary 6 _____

CHIJ ST NICHOLAS GIRLS' SCHOOL (PRIMARY)



**Primary 6 Mathematics
2019 Preliminary Examination**

Paper 2

20 August 2019

Paper 1	45
Paper 2	55
Total Marks	00

Parent's/Guardian's Signature

Time : 1 hour 30 minutes

INSTRUCTIONS TO CANDIDATES

Do not turn over this page until you are told to do so.

Follow all instructions carefully.

Answer all questions.

Write your answers in this booklet

The use of an approved calculator is expected, where appropriate.

This booklet consists of 16 printed pages including the cover page.

Questions 1 to 5 carry 2 marks each. Show your working clearly and write your answers in the spaces provided. For questions which require units, give your answers in the units stated. (10 marks)

Do not write in this space

1. Anan entered a number into his calculator. He added 11 to the number and then multiplied the sum by 22. Finally, he subtracted 48 from the product. In the end, he obtained 766 as the answer. What was the number Anan' entered into his calculator?

Ans : _____

2. A chef had a total mass of 6.05 kg of flour and sugar. He used $\frac{3}{4}$ of the flour and $\frac{1}{3}$ of the sugar to bake muffins. He had the same amount of flour and sugar left. How much flour did he have at first?

Ans : _____ kg _____ g



3. At an exhibition, the ratio of the number of men to the number of women was $10 : 3$. Halfway through the exhibition, 110 men left and the number of men was $\frac{5}{12}$ of the total number of people who remained behind. How many women were there at the exhibition?

Do not write in this space

Ans : _____

4. CDFG is a square with O in the centre. CGE and CGO are triangles. What fraction of the square CDFG is unshaded?

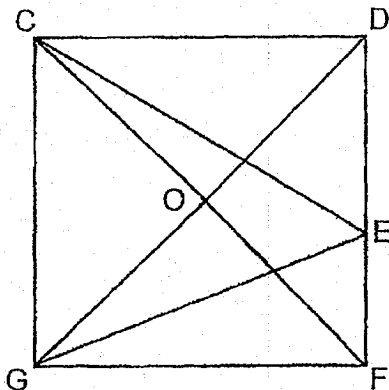

Ans : _____



5. At 5.50 p.m., Mr Diresb left his office to drive 50 km back to his house. He had to pass by a factory and a library. The library was 45 km away from his office and was exactly in the middle of the factory and his house. It was 6.20 p.m. when he passed by the factory. What was the average speed that he was driving at from his office to the factory?

Do not
write in
this space

Ans : _____ km/h

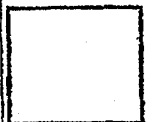

For questions 6 to 17, show your working clearly and write your answers in the spaces provided. The number of marks available is shown in the brackets () at the end of each question or part-question. (45 marks)

Do not write in this space

6. The pie chart below shows the different animals adopted by an animal shelter.

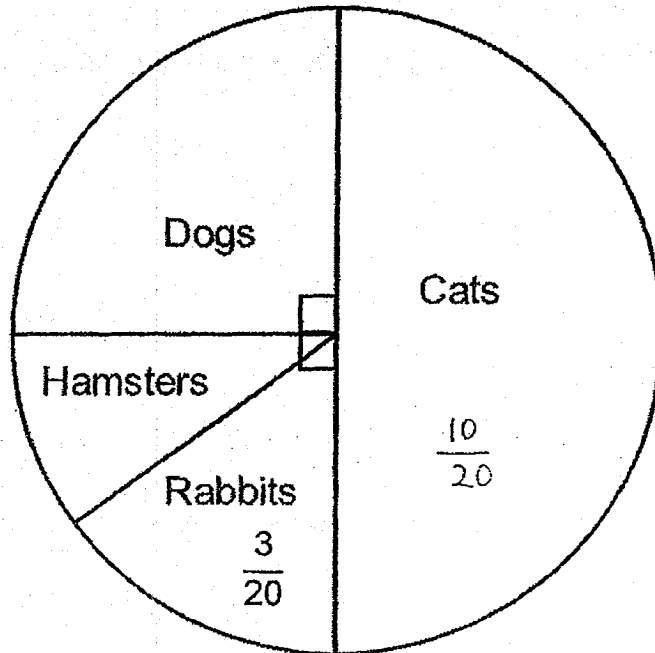

- (a) What fraction of all the animals adopted were hamsters?
- (b) A total number of 84 cats and hamsters were adopted. How many animals were adopted altogether?

Ans : (a) _____ [1]

(b) _____ [2]

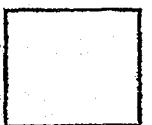

7. The table below shows the charges for domestic usage of water.

Amount of water used	Charges
Up to 40 m ³	146¢ per m ³
Above 40 m ³	102¢ per m ³

The Eng family paid a total amount of \$86.96 in June. How much water did the family use in June?

Do not
write in
this space

Ans : _____ [3]

8. Some identical small rectangles lie within a large rectangle ABCD as shown. The length of each rectangle is 24 cm. What is the area of the shaded part?

Do not write in this space

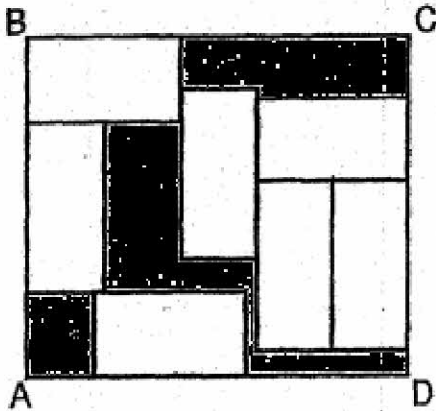

Ans : _____ [3]



9. Hathi had 180 twenty-cent coins and some five-cent coins. 80% of her coins were five-cent coins. Hathi used up 75% of the five-cent coins. What was the total value of the five-cent coins that she used up?

Do not
write in
this space

Ans : _____ [3]

10. In the figure below, ABC is a right-angled triangle. All the sides of AEF are equal. AF and BE are straight lines.

- (a) Name an isosceles triangle in the figure.
 (b) Find $\angle BDF$.

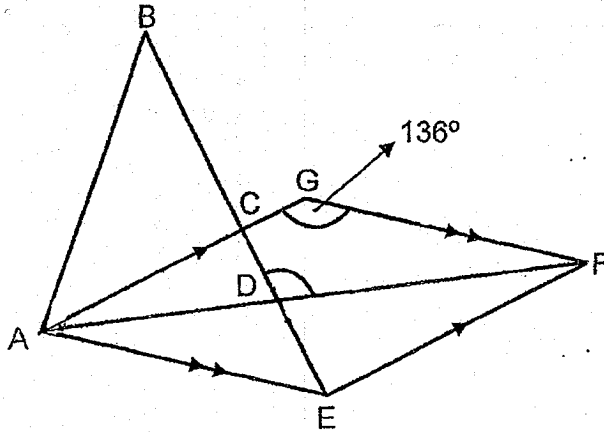

Do not write in this space

Ans : (a) Triangle _____ [1]

(b) _____ [2]



11. The figure below shows the net of an open rectangular box. Find the volume of the box.

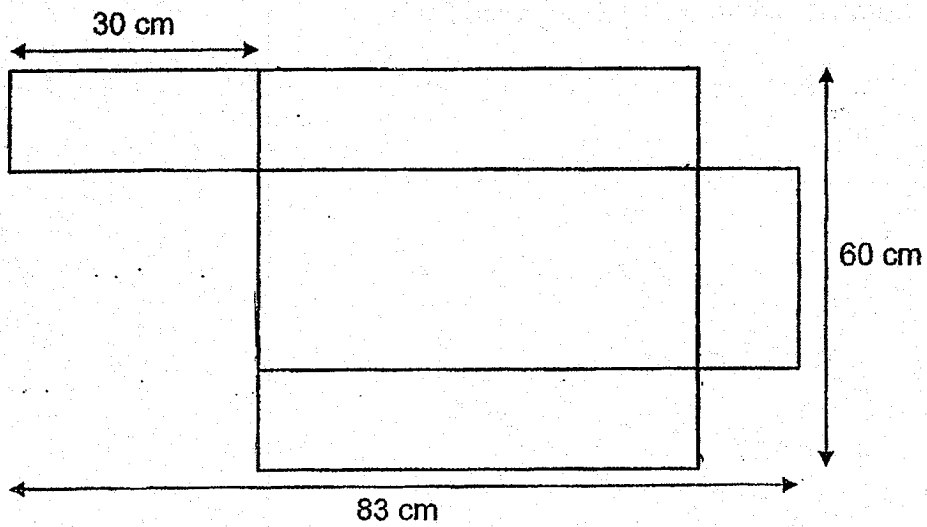

Do not write in this space

Ans : _____ [3]



12. Irin is now $2r$ years old. She is 10 years younger than Kexin. Junita is half the total age of Irin and Kexin.

Do not
write in
this space

(a) How old is Junita now? Leave your answer in terms of r .

(b) Given $r = 7$, what was the total age of the three girls 4 years ago?

Ans : (a) _____ [2]

(b) _____ [2]



13. The bar graph below shows the number of visitors at a museum over five months. The two bars that show the number of visitors in May and July have not been drawn.

Do not write in this space

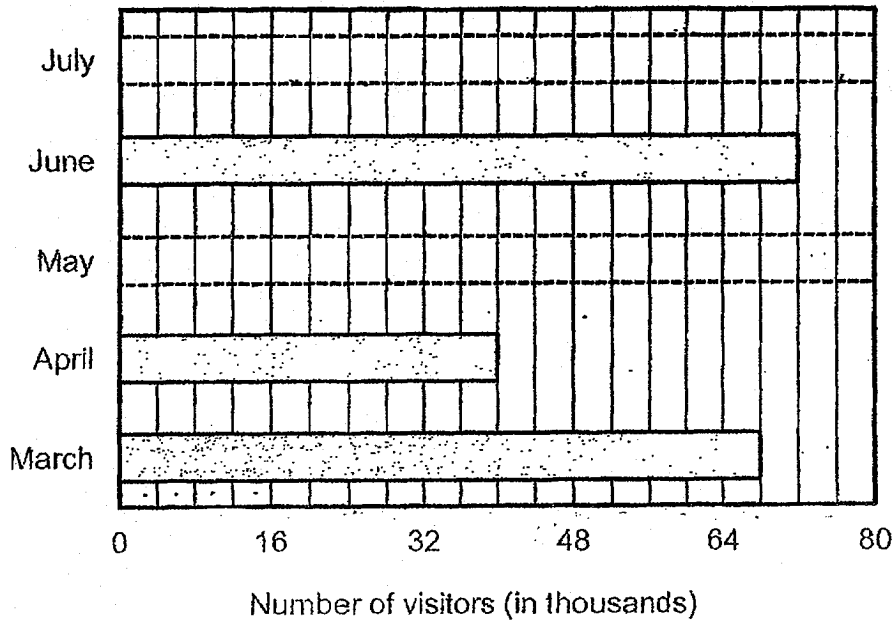

- (a) In May, the number of visitors decreased by 30% from April. There were 16 000 fewer visitors in May than in July. Draw the two bars representing the number of visitors in May and July. [3]
- (b) Write down all the months in which there were at least 44 000 visitors at the museum.

Ans : _____ [1]

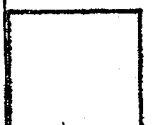

14. In the figure below, QRST is a rectangle, MNPL is a parallelogram and RUV is an equilateral triangle.

(a) Find $\angle URQ$.

(b) Find $\angle MLR$.

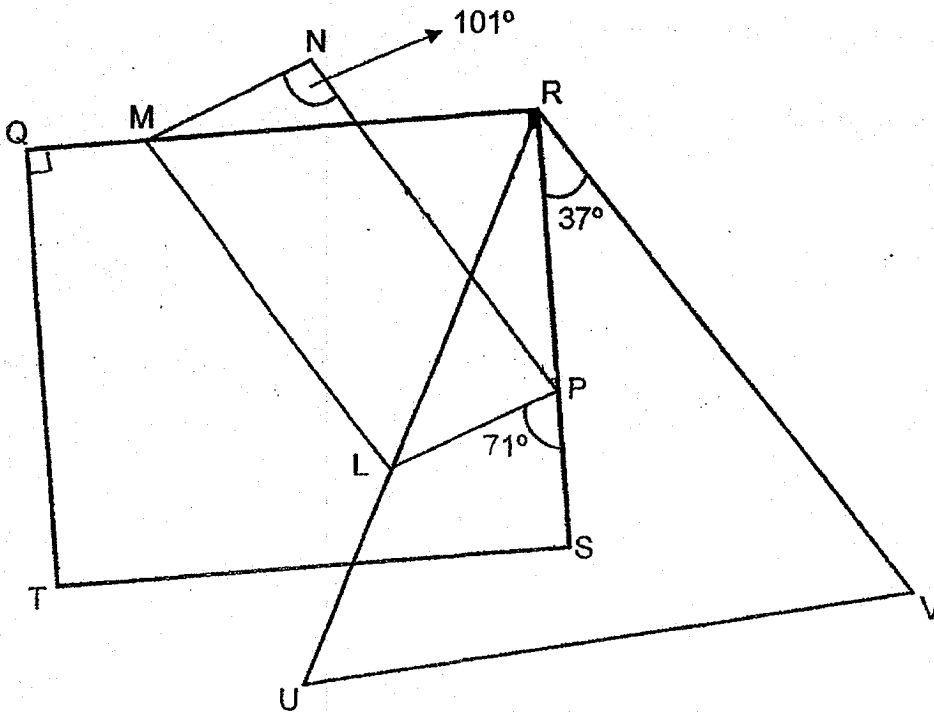

Do not write in this space

Ans : (a) _____ [1]

(b) _____ [3]

15. Ivana has \$189 and Janie has \$93 at the end of January. Starting from February, Ivana saves \$4 every week and Janie saves \$10 every week.

Do not
write in
this
space

(a) Janie wants to have the same total amount of money as Ivana.

(i) How many weeks does Janie need to save so that she will have the same total amount of money as Ivana?

(ii) What is this total amount of money Janie will have?

(b) Janie wants to have \$120 more than Ivana. How much money will Ivana have?

Ans : (a) (i) _____ [2]

(ii) _____ [1]

(b) _____ [2]



16. Matthias spent one week to read a book. He read some pages every day, starting on Monday.

On Monday, the ratio of the number of pages read to the number of pages not read was 1 : 5.

After he had read another 120 pages on Tuesday, 70% of the book was not read.

For the rest of the week, he read the same number of pages every day.

How many pages did Matthias read every day for the rest of the week?

Do not
write in
this
space

Ans : _____ [5]

17. At a camp, Mrs Sitoh arranged the pupils into 4 equal groups of boys and 5 equal groups of girls. In every group of girls, the number of girls was 5 more than the number of boys in each group. $\frac{3}{8}$ of all the pupils at the camp were boys. How many pupils were there altogether at the camp?

Do not
write in
this
space

Ans : _____ [5]

End of Paper



SCHOOL : CHIJ PRIMARY SCHOOL
 LEVEL : PRIMARY 6
 SUBJECT : MATH
 TERM : 2019 PRELIM

PAPER 1 BOOKLET A

Q 1	Q2	Q3	Q4	Q5	Q6	Q7	Q8	Q9	Q10
2	4	1	4	2	4	3	1	4	3

Q 11	Q12	Q13	Q14	Q15
2	1	2	1	3

PAPER 1 BOOKLET B

Q16)	$20 + 8 \times 10d \div 5 - d$ $= 20 + 80d \div 5 - d$ $= 20 + 16d - d$ $= 20 + 15d$ ANS:(15d + 20)
Q17)	$0.001 \times 690 = 0.001 \times 10 \times 69$ $= 0.01 \times 69$ $= 0.69$
Q18)	$0.1\% = \frac{1}{1000}$
Q19)	$180^\circ - 148^\circ = 32^\circ$ $32^\circ + 69^\circ = 101^\circ$ $180^\circ - 101^\circ = 79^\circ$
Q20)	$1700 \div 20 \div 10 = 17 \div 2$ $= 8.5 \text{ cm}$
Q21)	1, 2 ,7 and 14
Q22)	$26 + 32 + 29 + 15 = 102$ $102 : 15$ $= 34 : 5$

Q23)

X

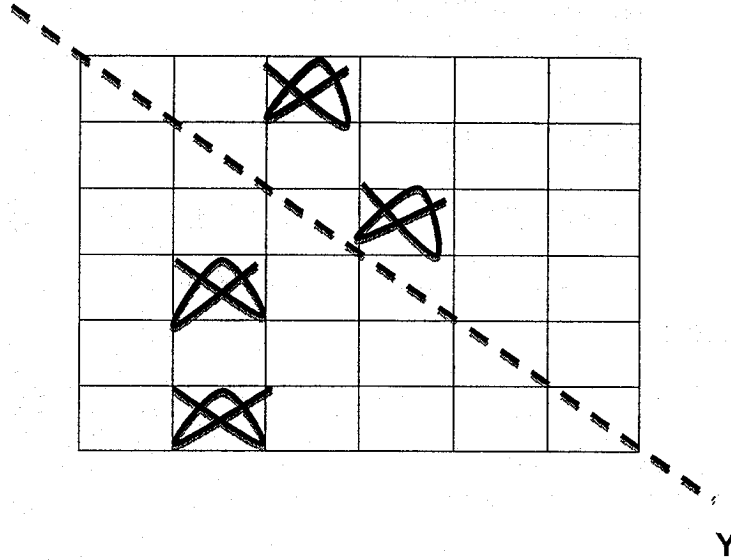

Q24)

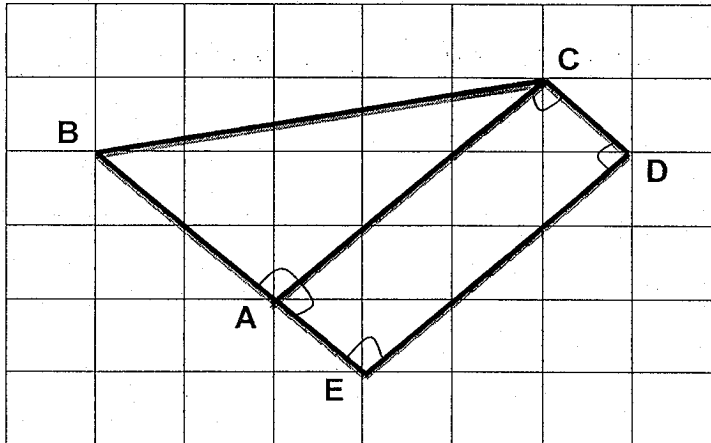

Q25)

$$\begin{aligned}
 32 \times 2 &= 64 \\
 26 \times 30 &= 780 \\
 20 \times 0.9 &= 0.9 \times 10 \times 2 \\
 &= 9 \times 2 = 18 \\
 64 + 780 &= 844 \\
 844 - 18 &= \$826
 \end{aligned}$$

Q26)

$$\begin{aligned}
 4 \times 22 &= 88 \\
 26 + 16 + 24 + 22 &= 88 \\
 \text{ANS: } &16
 \end{aligned}$$

Q27)

$$\begin{aligned}
 123 + 39 &= 162 \\
 162 - 27 &= 135 \\
 135 \div 9 &= 15 \\
 15 \times 5 &= 75 \\
 75 - 39 &= 36
 \end{aligned}$$

Q28)	$34 \div 2 = 17$ $17 \times 3 = 51$ $51 + 48 = 99$ $99\text{cm} = 0.99\text{m}$									
Q29)	$\frac{1}{4} \times \frac{22}{7} \times 28 = \frac{22}{7} \times \frac{7}{1} = 22$ $98 - 22 - 14 - 14 - 14 - 14 = 98 - 78$ $= 20 \text{ cm}$									
Q30)	<table border="1"> <thead> <tr> <th>True</th> <th>False</th> <th>Not</th> </tr> </thead> <tbody> <tr> <td></td> <td></td> <td>✓</td> </tr> <tr> <td></td> <td>✓</td> <td></td> </tr> </tbody> </table>	True	False	Not			✓		✓	
True	False	Not								
		✓								
	✓									

PAPER 2

Q1)	$766 + 48 = 814$ $814 \div 22 = 37$ $37 - 11 = 26$												
Q2)	$\frac{1}{4}$ of the flour = $\frac{2}{3}$ of the sugar $\frac{2}{8}$ of the flour = $\frac{2}{3}$ of the sugar $8 + 3 = 11$ $6.05 \div 11 = 0.55$ $0.55 \times 8 = 4.4$ $4.4\text{kg} = 4\text{kg } 400\text{g}$												
Q3)	<table style="width: 100%; border-collapse: collapse;"> <tr> <td style="width: 33%;">$M : W$</td> <td style="width: 33%;">$M : W$</td> <td style="width: 33%;">$12 - 5 = 7$</td> </tr> <tr> <td>$10 : 3$</td> <td>$70 : 21$</td> <td>$70 - 15 = 55$</td> </tr> <tr> <td>$5 : 7$</td> <td>$15 : 21$</td> <td>$110 \div 55 = 2$</td> </tr> <tr> <td>$2 \times 21 = 42$</td> <td></td> <td></td> </tr> </table>	$M : W$	$M : W$	$12 - 5 = 7$	$10 : 3$	$70 : 21$	$70 - 15 = 55$	$5 : 7$	$15 : 21$	$110 \div 55 = 2$	$2 \times 21 = 42$		
$M : W$	$M : W$	$12 - 5 = 7$											
$10 : 3$	$70 : 21$	$70 - 15 = 55$											
$5 : 7$	$15 : 21$	$110 \div 55 = 2$											
$2 \times 21 = 42$													
Q4)	$1 - \frac{1}{4} = \frac{3}{4}$												
Q5)	$50 - 45 = 5$ $45 - 5 = 40$ $40 \div 30 = 1\frac{1}{3}$ $1\frac{1}{3} \times 60 = 80 \text{ km/h}$												

Q6)	<p>a) $\frac{1}{4} - \frac{3}{20} = \frac{1}{10}$</p> <p>b) $10 + 2 = 12$ $84 \div 12 = 7$ $7 \times 20 = 140$</p>
Q7)	<p>$146\text{¢} = \\$1.46$ $102\text{¢} = \\$1.02$ $\\$1.46 \times 40 = \\58.40 $\\$186.96 - \\$58.40 = \\$28.56$ $\\$28.56 \div \\$1.02 = 28$ $28 + 40 = 68\text{m}^3$</p>
Q8)	<p>$24 \div 2 = 12$ $24 \times 12 = 288$ $288 \times 7 = 2016$ $24 + 12 + 24 = 60$ $24 + 12 + 12 = 48$ $60 \times 48 = 2880$ $2880 - 2016 = 864\text{cm}^2$</p>
Q9)	<p>$20\text{¢} : 5\text{¢}$ $180 \div 2 = 90$ $2 : 8$ $\begin{array}{r} \times 10 \\ \times 90 \\ \hline \end{array}$ $180 : 720$</p> <p>$\frac{75}{100} \times 720 = 540$ $540 \times \\$0.05 = \\27</p>
Q10)	<p>a) AEF b) $180^\circ - 136^\circ = 44^\circ$ $44^\circ \div 2 = 22^\circ$ $180^\circ - 90^\circ - 22^\circ = 68^\circ$ $180^\circ - 68^\circ = 112^\circ$</p>
Q11)	<p>$60 - 30 = 30$ $30 \div 2 = 15$ $83 - 30 - 15 = 38$ $38 \times 30 \times 15 = 17100\text{cm}^3$</p>

Q12) a) $10 \div 2 = 5$
 $r + r + 5 = (2r + 5)$ years old
 b) $r = 7$
 $r + r + r + r + r + r + 10 + 5$
 $= (7 \times 6) + 10 + 5 = 57$
 $57 - 4 - 4 - 4 = 45$ years

Q13) a) $\frac{7}{10} \times 40 = 28$
 $16000 \div 1000 = 16$
 $28 + 16 = 44$

b) March, June and July

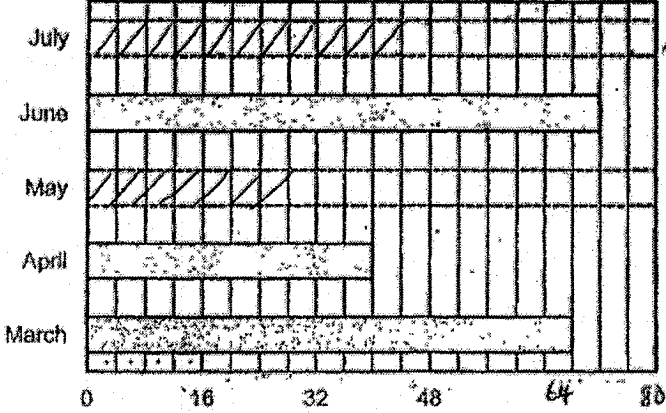

Month	Number of visitors (in thousands)
July	44
June	44
May	28
April	32
March	44

Q14) a) $180^\circ \div 3 = 60^\circ$
 $60^\circ - 37^\circ = 23^\circ$
 $90^\circ - 23^\circ = 67^\circ$
 b) $180^\circ - 71^\circ = 109^\circ$
 $180^\circ - 109^\circ - 23^\circ = 48^\circ$
 $101^\circ - 48^\circ = 53^\circ$

Q15) a) i) $189 - 93 = 96$
 $10 - 4 = 6$
 $96 \div 6 = 16$ week
 aii) $16 \times 10 = 160$
 $160 + 93 = \$253$
 b) $120 \div 6 = 20$
 $20 + 16 = 36$
 $36 \times 4 = 144$
 $189 + 144 = \$333$

Q16) $\frac{3}{10} - \frac{1}{6} = \frac{2}{15}$

$$120 \div 2 = 60$$

$$60 \div 2 = 30$$

$$\frac{7}{10} \times 3 = \frac{21}{30}$$

$$30 \times 21 = 630$$

$$7 - 2 = 5$$

$$630 \div 5 = 126$$

Q17) $\frac{5}{8} \rightarrow 20 \text{ units} = 15 \text{ units} + 25$

$$5 \text{ units} = 25$$

$$1 \text{ unit} = 25 \div 5 = 5$$

$$5 \times 32 = 160$$



2019 PRIMARY 6 PRELIMINARY EXAMINATION

Name: _____ () Date: 22 August 2019

Class: Primary 6 ()

Time: 8.00 a.m. – 9.00 a.m.

Parent's Signature: _____

MATHEMATICS

PAPER 1

(BOOKLET A)

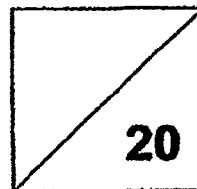

INSTRUCTIONS TO CANDIDATE

1. Write your name, class and register number.
2. Do not turn over this page until you are told to do so.
3. Follow all instructions carefully.
4. Answer all questions.
5. Show your working clearly as marks are awarded for correct working.
6. You are NOT allowed to use a calculator.

Questions 1 to 10 carry 1 mark each. Questions 11 to 15 carry 2 marks each. For each question, four options are given. One of them is the correct answer. Make your choice (1, 2, 3 or 4). Shade the correct oval on the Optical Answer Sheet. (20 marks)

Q1. Round 588 619 to the nearest thousand.

- (1) 580 000
- (2) 588 000
- (3) 589 000
- (4) 590 000

Q2. Which of the following is equal to $\frac{11}{4} \div \frac{1}{4}$?

- (1) $\frac{11}{4} \times \frac{4}{1}$
- (2) $\frac{11}{4} + \frac{4}{1}$
- (3) $\frac{4}{11} \times \frac{1}{4}$
- (4) $\frac{4}{11} \div \frac{1}{4}$

Q3. Which of the following is the same as 20 kg 30 g?

- (1) 2 030 g
- (2) 2 300 g
- (3) 20 030 g
- (4) 20 300 g

Q4. Express $10\frac{1}{20}$ as a decimal.

- (1) 10.02
- (2) 10.05
- (3) 10.20
- (4) 10.50

Q5. Which of the following is greater than $\frac{7}{8}$?

- (1) $\frac{2}{3}$
- (2) $\frac{4}{5}$
- (3) $\frac{5}{6}$
- (4) $\frac{8}{9}$

Q6. The diameter of a wheel is 56 cm. What is the circumference of the wheel?

(Take $\pi = \frac{22}{7}$)

- (1) 88 cm
- (2) 176 cm
- (3) 352 cm
- (4) 784 cm

**Q7. Siti is facing north-east after turning 270° anti-clockwise.
What direction was she facing at first?**

- (1) West**
- (2) South**
- (3) South-east**
- (4) North-west**

**Q8. There are 35 students in a class. 15 of them are girls while the rest are boys.
What is the ratio of the number of boys to the number of girls in the class?**

- (1) 3 : 4**
- (2) 3 : 7**
- (3) 4 : 3**
- (4) 4 : 7**

**Q9. After spending 60% of his savings on some books, Peter has \$400 left.
How much did he spend on the books?**

- (1) \$160**
- (2) \$240**
- (3) \$600**
- (4) \$1 000**

**Q10. The pie chart represents the number of fruits sold by a fruit stall.
If 30 oranges were sold, how many pears were sold?**

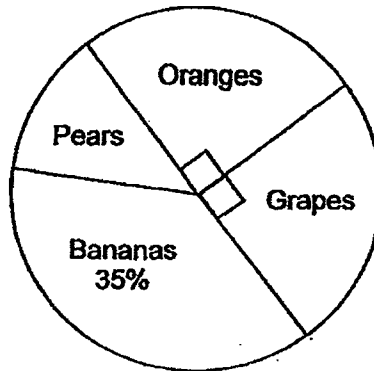

- (1) 15
- (2) 18
- (3) 30
- (4) 55

**Q11. Siying and Anna were standing in a queue to enter a concert.
Siying was exactly in the middle of the queue.
Anna was the 43rd person after Siying and there are another 20 people after
Anna. How many people were there in the queue?**

- (1) 63
- (2) 65
- (3) 126
- (4) 127

- Q12. The following figure is made up of three shapes. QRST is a parallelogram. STU is an isosceles triangle. RSV is a right-angled triangle. RSU is a straight line. Which one of the following angles cannot be found?

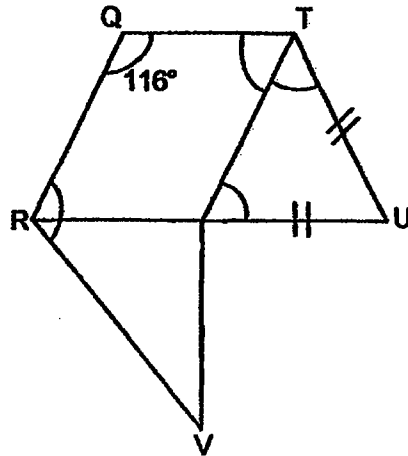

- (1) $\angle STU$
- (2) $\angle STQ$
- (3) $\angle QRV$
- (4) $\angle RST$

- Q13. The first 14 numbers of a number pattern are given below.
How many number '8' are there in the first 130 numbers?

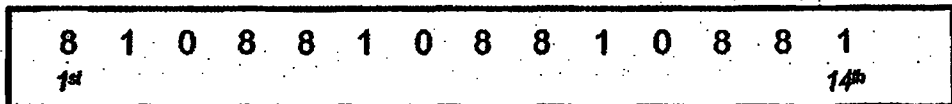

- (1) 33
- (2) 52
- (3) 64
- (4) 65

- Q14. The figure below shows 2 rectangles of the same size. $BC = CF = FG$.
The area of Rectangle ABCD is 100 cm^2 . What is the area of triangle FGH?

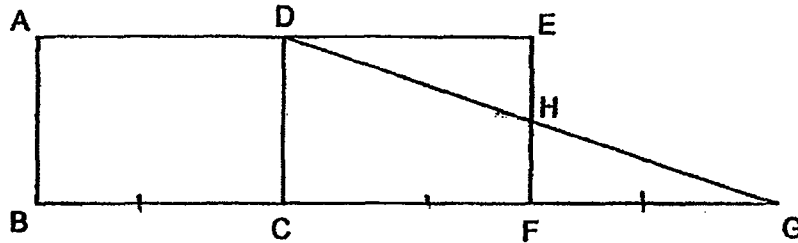

- (1) 25 cm^2
(2) 50 cm^2
(3) 75 cm^2
(4) 100 cm^2
- Q15. The average mass of Fruit A and Fruit B is 6 kg.
The mass of Fruit A mass is half the mass of Fruit B.
Find the mass of Fruit B.

- (1) 8 kg
(2) 2 kg
(3) 3 kg
(4) 4 kg

- END OF BOOKLET A -



2019 PRIMARY 6 PRELIMINARY EXAMINATION

Name: _____ () Date: 22 August 2019

Class: Primary 6 () Time: 8.00 a.m. – 9.00 a.m.

Parent's Signature: _____

MATHEMATICS

PAPER 1

(BOOKLET B)

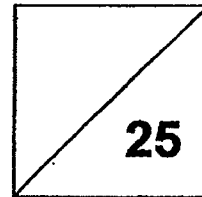

INSTRUCTIONS TO CANDIDATE

1. Write your name, class and register number.
2. Do not turn over this page until you are told to do so.
3. Follow all instructions carefully.
4. Answer all questions.
5. Show your working clearly as marks are awarded for correct working.
6. You are NOT allowed to use a calculator.

Questions 16 to 20 carry 1 mark each. Write your answers in the spaces provided. For questions which require units, give your answers in the units stated (5 marks)

Q16. 25% of a number is 24. What is $\frac{1}{3}$ of the number?

Ans: _____

Q17. A car is travelling at a speed of 70 km/h.
How long will the car take to travel 35 km?

Ans: _____ min

Q18. Express $\frac{6}{7}$ as a percentage.

Ans: _____ %

Q19. Arrange the following numbers in descending order.

0.107 , 10.07 , 1.07 , 10.70

_____ , _____ , _____ , _____
Greatest

Q20. Shade 2 more squares such that the figure below is symmetrical.

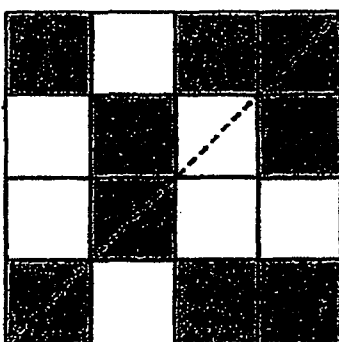

Questions 21 to 30 carry 2 marks each. Show your working clearly in the space provided for each question and write your answers in the spaces provided. For questions which require units, give your answers in the units stated. (20 marks)

Q21. Find the value of $98 - 24 + 2 + (51 - 47)$

Ans: _____

Q22. Find the value of $\frac{m}{5} \times m + 3$ when $m = 15$.

Ans: _____

Q23. Tom can paint a room in 2 hours while Ali can paint the same room in 3 hours. If Tom and Ali paint the room together, what fraction of the room can they paint in 1 hour?

Ans: _____

- Q24.** The figure below shows 2 semicircles. AB is twice of BC.
Find the area of the figure. Leave your answer in terms of π .

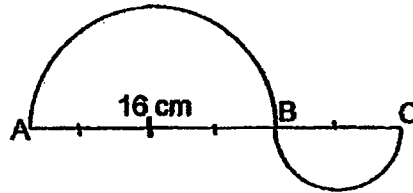

Ans: _____ cm^2

- Q25.** A rectangle has a breadth of $(2y + 1)$ cm long.
Its length is y cm longer than its breadth.
What is its perimeter in terms of y ?

Ans: _____ cm

Q26. Four landmarks of Tony's neighbourhood are shown in the square grid below.

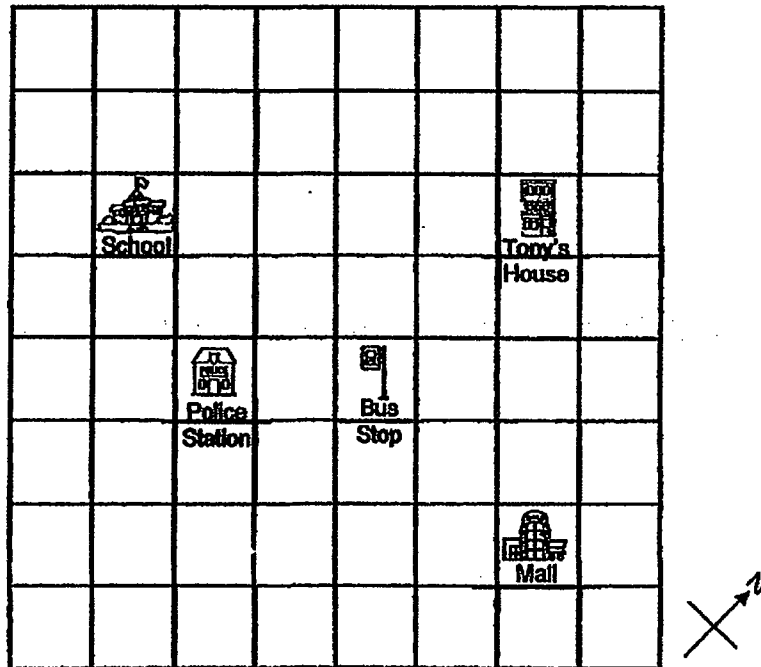

a) In which direction is Tony's house from the school?

b) A clinic is to be built directly south of Tony's house and south west of the Mall. Mark on the grid with an 'X' to show where the clinic will be built.

Ans: a) _____

**Q27. Andy gave 30% of his money to his sister and spent 40% of the remainder.
What percentage of his money was left?**

Ans: _____ %

**Q28. A shopping mall provides a shuttle bus service from the mall to the MRT
station every 50 minutes.
The first shuttle bus leaves the mall at 11 a.m. and there are 12 shuttle
services each day.
At what time is the last shuttle service?**

Ans: _____ p.m.

Q29. The graph below shows the amount of rainfall for Singapore in 2019 from January to June.

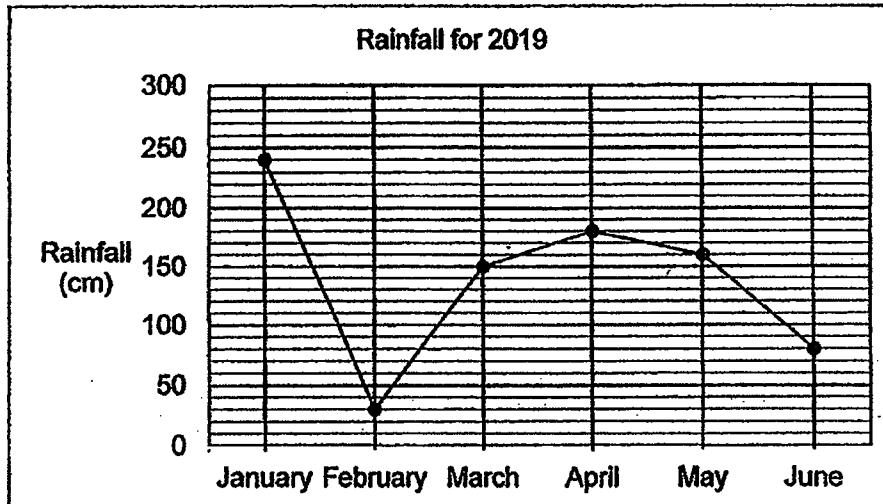

What was the average monthly rainfall from January to June?

Ans: _____ cm

Q30. In the figure below, not drawn to scale, MQ and NR are straight lines. $\angle POR$ is a right-angle. Find $\angle POQ$.

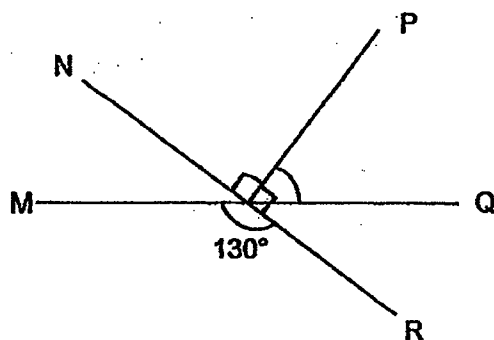

Ans: _____ °

- END OF BOOKLET B -



2019 PRIMARY 6 PRELIMINARY EXAMINATION

Name: _____ () Date: 22 August 2019

Class: Primary 6 () Time: 10.30 a.m. – 12.00 noon

Parent's Signature: _____

MATHEMATICS

PAPER 2

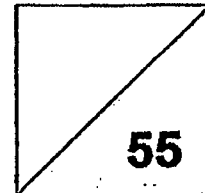

INSTRUCTIONS TO CANDIDATE

1. Write your name, class and register number.
2. Do not turn over this page until you are told to do so.
3. Follow all instructions carefully.
4. Answer all questions.
5. Show your working clearly as marks are awarded for correct working.
6. You are allowed to use a calculator.

Questions 1 to 5 carry 2 marks each. Show your working clearly in the space provided for each question and write your answers in the spaces provided. For questions which require units, give your answers in the units stated. (10 marks)

Q1. How many common factors of 44 and 88 are there?

Ans: _____

Q2. The figure below shows 2 identical squares. The shaded area is 15% of each square. Find the ratio of the shaded area to the area of the figure.

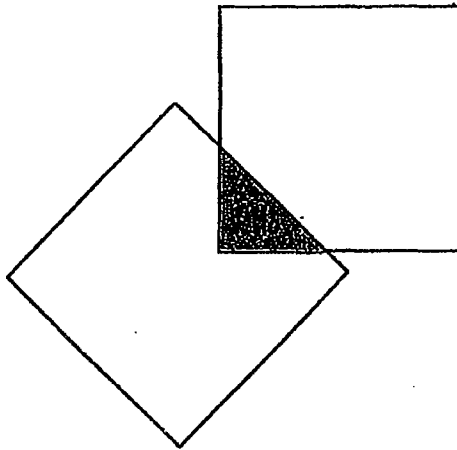

Ans: _____

- Q3. The following drawing shows an incorrect net of a cube.
Mark 'X' on the face(s) which is/are incorrect.

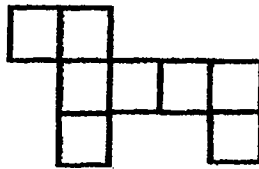

- Q4. Mrs Tan is 4 times as old as her son. Her son is 8 years old.
In how many years' time would her son be $\frac{1}{3}$ of Mrs Tan's age?

Ans: _____ years' time

- Q5. The figures are made up of squares. Study the pattern.
How many squares are there in Figure 13?

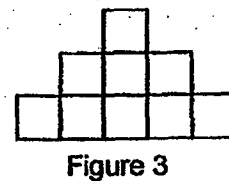
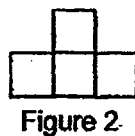
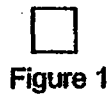

Ans: _____

For questions 6 to 17, show your working clearly in the space provided for each question and write your answers in the spaces provided. The number of marks available is shown in brackets [] at the end of each question or part-question.

(45 marks)

Q6. A bottle of body wash costs \$11 and a bottle of shampoo costs \$18.

During a sale, 2 bottles of body wash and a bottle of shampoo are sold at a discounted price of \$32. What is the percentage discount given during the sale?

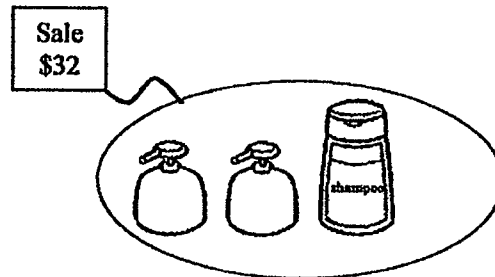

Ans: _____ [3]

Q7. A leaking tap leaks 2 ml of water in 1 second.

- How many litres of water is wasted if the tap leaks for a whole day?
- If the water costs 20 cents per litre, how much would the wasted water cost?

Ans: a) _____ [2]

b) _____ [1]

- Q8. Mr Chan drove from Town M to Town P at a speed of 65 km/h.
 Mr Lim drove 340 km from Town P to Town Q at a speed of 85 km/h.
 If both drivers took the same time to drive to their respective destinations,
 what is the distance between Town M and Town P?

Ans: _____ [3]

- Q9. DE and FG are parallel lines. $\angle HBC$ is 112° and $\angle GCJ$ is 76° .

- a) Find $\angle BAC$.
 b) Find $\angle DAB$.

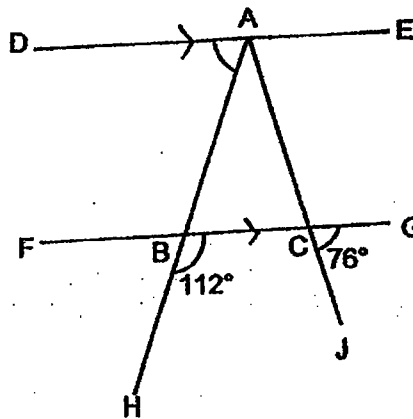

Ans: a) _____ [2]

b) _____ [1]

Q10. At a party, $\frac{1}{3}$ of the people were men. $\frac{3}{8}$ of the remainder were women and the rest were children. There are 55 adults. How many children were at the party?

Ans: _____ [3]

**Q11. At a concert, there were 402 people in the audience.
A child's ticket costs half as much as the cost of an adult ticket.
An adult ticket costs \$58.
A total of \$17 690 was collected from all the tickets sold.**

- a) Find the cost of a child's ticket.**
- b) How many children were in the audience?**

Ans: a) _____ [1]

b) _____ [3]

Q12. Company A and Company B sent their recyclable waste for recycling in the quantities shown in the table below.

	Plastic (kg)	Paper (kg)	Glass (kg)
Company A	90	75	56
Company B	100	50	84

Both companies were paid for their recyclable waste according to the charges as shown in the table below.

Recyclable	Price per kg
Plastic	\$0.30
Paper	\$0.80
Glass	\$1.00

a) Which Company, A or B, received more money for their recycling efforts?
How much more?

b) Study the above information carefully.

Each of the statements below is either True, False or Not Possible to Tell from the information given.

For each statement, put a tick (✓) to indicate your answer.

		True	False	Not Possible to Tell
(i)	Company A collected more money from recycling plastic waste than glass waste.			
(ii)	Company A collected 50% more paper waste than Company B.			

Ans: a) Company _____ [1]

Amount: _____ [1]

b) (tick your answers) [2]

Q13. The figure shows a circle and a right-angled isosceles triangle.
 $AB = BC = 20$ cm. Find the shaded area. (Take $\pi = 3.14$)

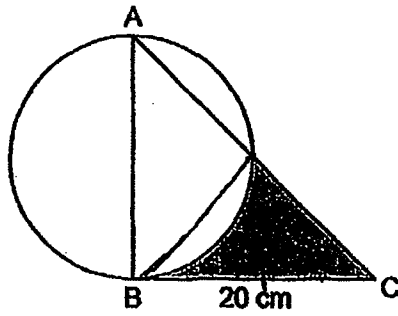

Ans: _____ [4]

**Q14. The average mass of Ahmad, Brian, Caili and Devi is 38 kg.
The average mass of Ahmad, Brian and Caili is 37 kg while the total mass of
Caili and Devi is 77 kg.**

- a) Find Caili's mass.**
- b) Brian and Devi have the same mass. Find Ahmad's mass.**

Ans: a) _____ [2]

b) _____ [2]

**Q15. A bakery baked buns and cakes in the morning in the ratio 4 : 1.
After selling 50 buns and 10 cakes in the afternoon, the ratio of the number of
buns to the number of cakes left became 3 : 1.**

- a) Find the number of buns that the bakery baked in the morning.**
- b) Find the number of cakes left.**

Ans: a) _____ [3]

b) _____ [1]

Q16. A and B are two rectangular containers. At first, the water level in Container A and B is as shown. The amount of water in Container A is 5 times that of the water in Container B. Then Keith poured some water from Container A into Container B until the water level in both containers are of the same height.

a) Find the volume of water in Container B.

b) Find the increase in water level of Container B.

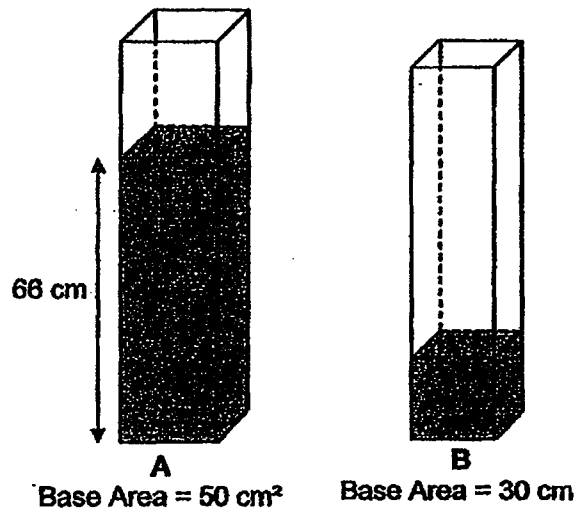

Ans: a) _____ [1]

b) _____ [4]

Q17. Doughnuts and cupcakes were sold in packs by ABC Bakery. Mrs Kumar, Mrs Fauziah and Mrs Leong bought doughnuts and cupcakes at the prices shown below.

Doughnuts

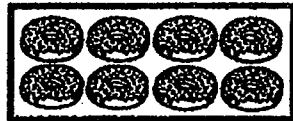

4 packs for \$12

Cupcakes

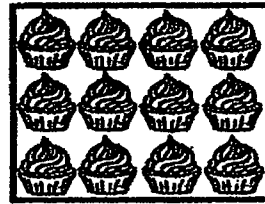

6 packs for \$15

- a) Mrs Kumar wanted to spend an equal amount of money on doughnuts and cupcakes. Find the minimum number of packs of cupcakes she bought.
- b) Mrs Leong bought some packs of doughnuts and Mrs Fauziah spent \$84 on doughnuts. Mrs Fauziah then gave Mrs Leong 20 doughnuts. In the end, Mrs Fauziah had 88 more doughnuts than Mrs Leong. How many packs of doughnuts did Mrs Leong buy?

Ans: a) _____ [2]

b) _____ [3]

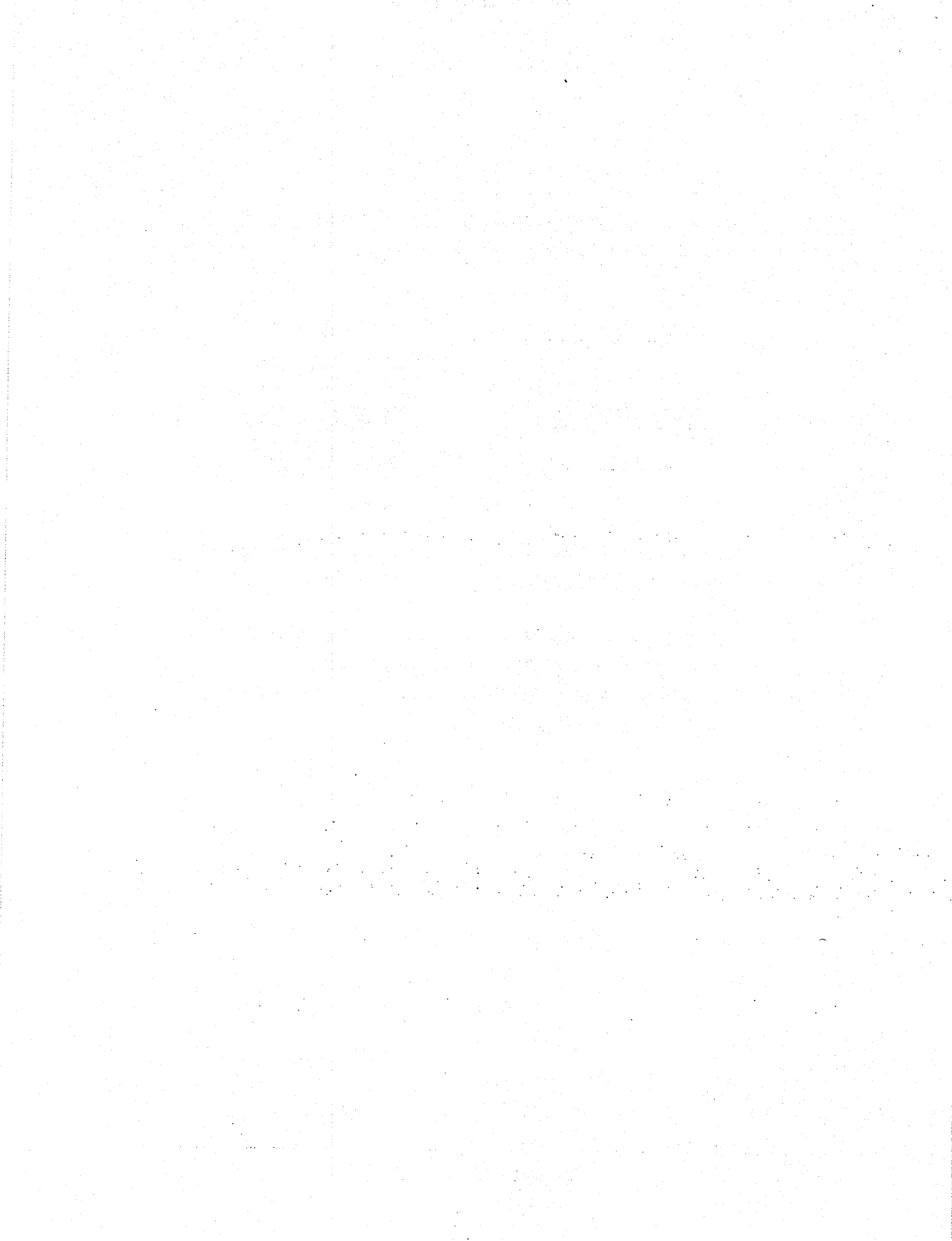

SCHOOL : TAO NAN PRIMARY SCHOOL
 LEVEL : PRIMARY 6
 SUBJECT : MATH
 TERM : 2019 PRELIM

PAPER 1 BOOKLET A

Q 1	Q2	Q3	Q4	Q5	Q6	Q7	Q8	Q9	Q10
3	1	3	2	4	2	4	3	3	2

Q 11	Q12	Q13	Q14	Q15
4	3	4	1	1

PAPER 1 BOOKLET B

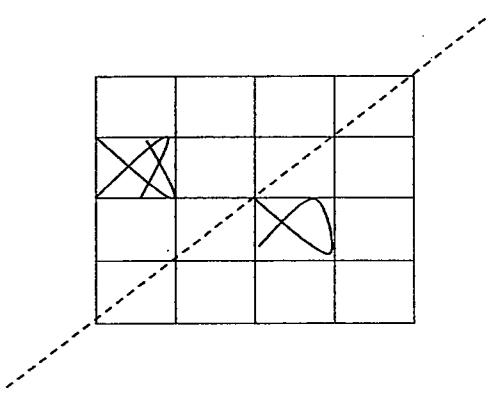
Q16)	$24 \div 25 \times 100 = 96$ $\frac{1}{3}$ of 96 = $96 \div 3 = 32$
Q17)	$35\text{km} \div 70\text{km/h} = 0.5\text{h}$ $= 30 \text{ min}$
Q18)	$85\frac{5}{7}\%$
Q19)	10.7 , 10.07 , 1.07 , 0.107
Q20)	
Q21)	$98 - 24 \div 2 + (51 - 47)$ $= 98 - 12 + 4 = 90$

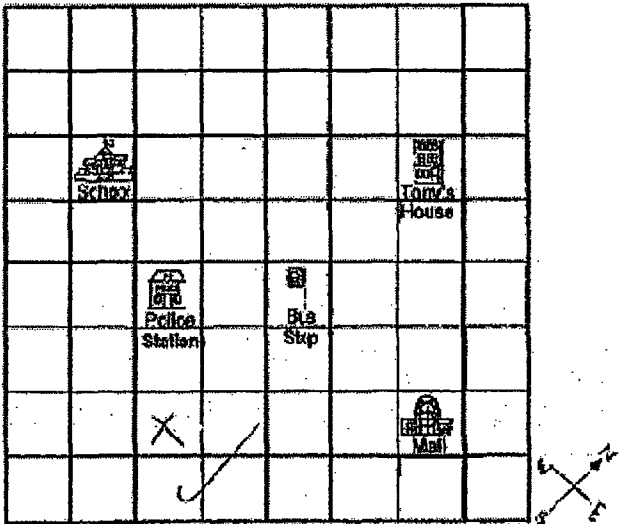
Q22)	$\frac{15}{5} \times 15 + 3 = 15 \times 3 + 3 = 48$						
Q23)	<table style="width: 100%; border: none;"> <tr> <td style="width: 50%; border: none;">Tom</td> <td style="width: 50%; border: none;">Ali</td> </tr> <tr> <td style="border: none;">In 1 hour \rightarrow $\frac{1}{2}$ of room</td> <td style="border: none;">in 1 hour \rightarrow $\frac{1}{3}$ of room</td> </tr> <tr> <td colspan="2" style="border: none; text-align: center;">$\frac{1}{2} + \frac{1}{3} = \frac{3}{6} + \frac{2}{6} = \frac{5}{6}$</td> </tr> </table>	Tom	Ali	In 1 hour \rightarrow $\frac{1}{2}$ of room	in 1 hour \rightarrow $\frac{1}{3}$ of room	$\frac{1}{2} + \frac{1}{3} = \frac{3}{6} + \frac{2}{6} = \frac{5}{6}$	
Tom	Ali						
In 1 hour \rightarrow $\frac{1}{2}$ of room	in 1 hour \rightarrow $\frac{1}{3}$ of room						
$\frac{1}{2} + \frac{1}{3} = \frac{3}{6} + \frac{2}{6} = \frac{5}{6}$							
Q24)	$16\text{cm} \div 2 = 8\text{cm}$ $8\text{cm} \div 2 = 4\text{cm}$ Area = $(\pi \times 8\text{cm} \times 8\text{cm} + \pi \times 4\text{cm} \times 4\text{cm}) \div 2$ $= (64\pi \text{ cm}^2 + 16\pi \text{ cm}^2) \div 2$ $= 80\pi \text{ cm}^2 \div 2 = 40\pi \text{ cm}^2$						
Q25)	Perimeter (in cm) = $(2y + 1) \times 4 + 2 \times y$ $= 8y + 4 + 2y$ $= (10y + 4)\text{cm}$						
Q26)	<p>a)</p>  <p>b) North-east</p>						
Q27)	$40\% \text{ of } 70 = \frac{70}{5} \times 2 = 28$ $100\% - 28\% - 30\% = 42\%$						
Q28)	8.10p.m						
Q29)	$(240\text{cm} + 30\text{cm} + 150\text{cm} + 180\text{cm} + 160\text{cm} + 80\text{cm}) \div 6$ $= 840\text{cm} \div 6 = 140\text{cm}$						

Q30)	$\angle NOQ = 130^\circ$ $\angle POQ = 130^\circ - 90^\circ = 40^\circ$
------	--

PAPER 2

Q1)	6
Q2)	$100\% - 15\% = 85\%$ Shaded area : Area of figure $15 : 85+15+85$ $15 : 185$ $3 : 37$
Q3)	
Q4)	$8 \times 3 = 24$ $24 \div 2 = 12$ $12 - 8 = 4$
Q5)	No. of squares = $13 \times 13 = 169$
Q6)	Usual price = $\$11 \times 2 + \$18 = \$40$ Percentage discount = $\frac{40-32}{40} \times 100\% = 20\%$
Q7)	a) $86400 \times 2ml = 172800ml = 172.8 l$ b) $0.20 \times 172.8 = \$34.56$
Q8)	Time taken = $340km \div 85km/h = 4h$ Distance between M and P = $65km/h \times 4h = 260km$
Q9)	a) $\angle ACB = 76^\circ$ $\angle BAC = 112^\circ - 76^\circ = 36^\circ$ $\angle BAC$ is 36° b) $\angle EAC = 76^\circ$ $\angle DAB = 180^\circ - 36^\circ - 76^\circ = 68^\circ$ $\angle DAB$ is 68°
Q10)	$4 \text{ units} = 55 \div 11 \times 4 = 20$

Q11)	<p>a) cost of a child's ticket = $\\$58 \div 2 = \\29 b) $402 \times \\$58 = \\23316 Extra = $\\$23316 - \\$17690 = \\$5626$ Diff = $\\$58 - \\$29 = \\$29$ No. of children = $\\$5626 \div \\$29 = 194$</p>		
Q12)	<p>a) Company : B <table style="width: 100%; border: none;"> <tr> <td style="width: 50%; vertical-align: top;"> <p>company A $\\$0.30 \times 90 + \\$0.80 \times 75 + \\$1 \times 56$ = \$143</p> </td> <td style="width: 50%; vertical-align: top;"> <p>company B $\\$0.30 \times 100 + \\$0.80 \times 50 + \\$1 \times 84$ = \$154</p> </td> </tr> </table> <p>Difference = $\\$154 - \\$143 = \\$11$ b) i) False ii) True</p> </p>	<p>company A $\\$0.30 \times 90 + \\$0.80 \times 75 + \\$1 \times 56$ = \$143</p>	<p>company B $\\$0.30 \times 100 + \\$0.80 \times 50 + \\$1 \times 84$ = \$154</p>
<p>company A $\\$0.30 \times 90 + \\$0.80 \times 75 + \\$1 \times 56$ = \$143</p>	<p>company B $\\$0.30 \times 100 + \\$0.80 \times 50 + \\$1 \times 84$ = \$154</p>		
Q13)	<p>$20\text{cm} \div 2 = 10\text{cm}$ Area of triangle = $\frac{1}{2} \times 20\text{cm} \times 10\text{cm} = 100\text{cm}^2$ Area of semicircle = $\frac{1}{2} \times 3.14 \times 10\text{cm} \times 10\text{cm} = 157\text{cm}^2$ $157\text{cm}^2 - 100\text{cm}^2 \div 2 = 28.5\text{cm}^2$ Area of shaded = $100\text{cm}^2 - 28.5\text{cm}^2 = 71.5\text{cm}^2$</p>		
Q14)	<p>a) Total mass of Ahmad, Brian, Caili and Devi = $38\text{kg} \times 4 = 152\text{kg}$ total mass of Ahmad, Brian, Caili = $37\text{kg} \times 3 = 111\text{kg}$ Devi's mass = $152\text{kg} - 111\text{kg} = 41\text{kg}$ Caili mass = $77\text{kg} - 41\text{kg} = 36\text{kg}$ b) Ahmad's mass = $152\text{kg} - 36\text{kg} - 41\text{kg} - 41\text{kg} = 34\text{kg}$</p>		
Q15)	<p>$50 - 40 = 10$ $4 - 1 = 3$ 3 units = $p + p + 40 = 2p + 40$ 1 unit = $1p + 10$ 2 units = $(1p + 10) \times 2 = 2p + 20$ 1 unit = $2p + 40 - 2p + 20 = 20$ $P = 20 - 10 = 10$ No. of buns baked in the morning = $50 + 10 \times 3 = 80$ No. of cakes left = $p = 10$ a) The bakery baked 80 buns. b) 10 cakes were left</p>		
Q16)	<p>a) volume of water in B at the end = $\frac{3960\text{cm}^3}{5+3} \times 3 = 1485\text{cm}^3$ b) Diff = $1485\text{cm}^3 - 660\text{cm}^3 = 825\text{cm}^3$ increase in water level = $825\text{cm}^3 \div 30\text{cm}^2 = 27.5\text{cm}$</p>		

Q17) a) LCM of (12,15) = $2 \times 2 \times 3 \times 5 = 60$

No. of packs of cupcakes = $\frac{\$60}{\$15} \times 6 = 24$

b) No. of packs Mrs Fauziah bought = $\frac{\$84}{\$12} \times 4 = 28$

No. of doughnuts = $28 \times 8 = 224$

$224 - 20 = 204$

$204 - 88 = 116$

$116 - 20 = 96$

No. of packs Mrs Leong bought = $\frac{96}{8} = 12$



Rosyth School
Preliminary Examination 2020
Mathematics
Paper 1
Primary 6

Name: _____

Register No. _____

Class: Pr 6 - _____

Date: 25 August 2020

Parent's Signature: _____

Total Time for Booklets A and B : 1 hour

Booklet A

Instructions to Pupils:

1. Do not open this booklet until you are told to do so.
2. Follow all instructions carefully.
3. Shade your answers in the Optical Answer Sheet (OAS) provided.
4. You are not allowed to use a calculator.
5. Answer all questions.

Section	Maximum Mark	Marks Obtained
Paper 1 (Booklet A)	20	

* This booklet consists of 8 pages (including this cover page).

Questions 1 to 10 carry 1 mark each. Questions 11 to 15 carry 2 marks each.
For each question, four options are given. One of them is the correct answer.
Make your choice (1, 2, 3 or 4). Shade the oval (1, 2, 3 or 4) on the Optical Answer Sheet.

All diagrams in this paper are not drawn to scale unless stated otherwise.

(20 marks)

1 Round off 80 282 to the nearest tenth.

- (1) 80
- (2) 80.2
- (3) 80.3
- (4) 80.28

2 Express $6 + 10f - 4 + 2f$ in the simplest form.

- (1) $12f + 2$
- (2) $12f + 10$
- (3) $14f - 4$
- (4) $18f - 4$

3 The average amount of money saved by Annie and Ben was \$36. Annie saved three times as much as Ben. How much did Ben save?

- (1) \$ 9
- (2) \$18
- (3) \$54
- (4) \$72

4. What is the length of the pencil in the figure below?

- (1) 5.2 cm
- (2) 5.4 cm
- (3) 5.8 cm
- (4) 6.0 cm

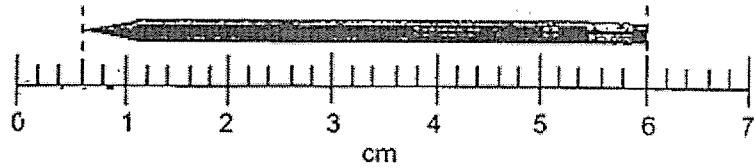

5. What is the possible mass of the watermelon in the figure below?

- (1) 6.5 g
- (2) 65 g
- (3) 6.5 kg
- (4) 65 kg

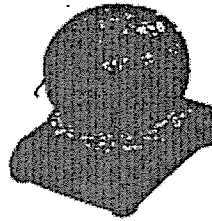

6. Weng is facing East.
He turns 225° in a clockwise direction.
He then turns 45° in an anti-clockwise direction.
Which direction is he facing now?

- (1) North
- (2) South
- (3) East
- (4) West

7 Which two lines are perpendicular to each other?

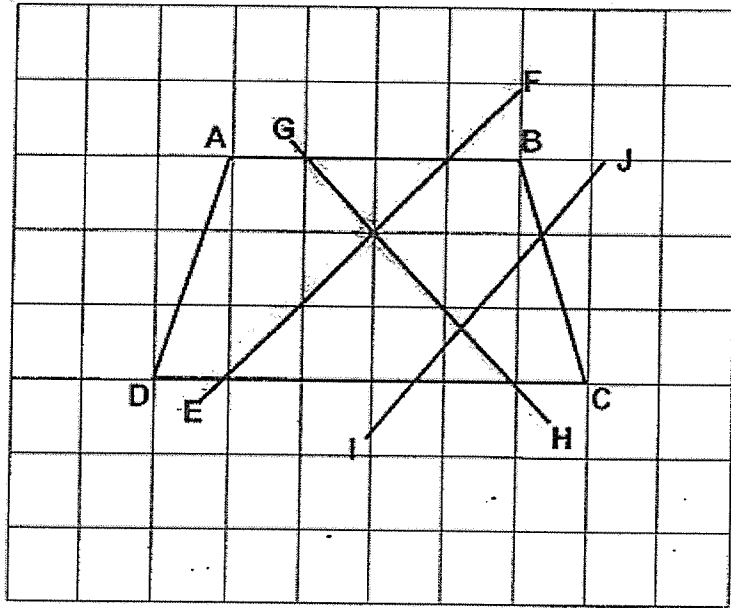

- (1) AB and CD
- (2) GH and IJ
- (3) EF and IJ
- (4) GH and EF

- 8 In the figure below, ABCD is a trapezium. EDC is a straight line. AB is parallel to DC. Find $\angle DAB$.

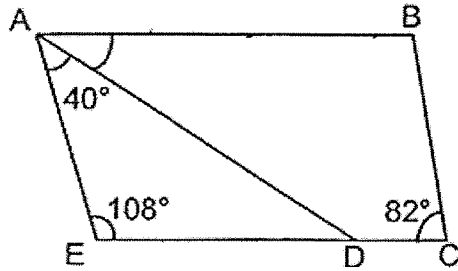

- (1) 22°
- (2) 32°
- (3) 42°
- (4) 68°

- 9 The figure below is made up of 3 straight lines. Find $\angle w$.

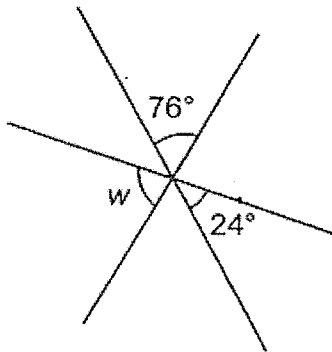

- (1) 66°
- (2) 80°
- (3) 100°
- (4) 104°

- 10 The table below shows the rental fees for skates.

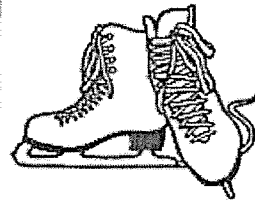
Skates for Rent		
First hour	\$10 per pair	
Every additional $\frac{1}{2}$ hour	\$6 per pair	

Cedelle rented a pair of skates from 10 am to 12 noon. How much did she pay?

- (1) \$16
(2) \$20
(3) \$22
(4) \$32
- 11 A number when divided by 10 gives a remainder of 7. Which of the following can be added to the number to change it to a multiple of 5?
- (1) 5
(2) 2
(3) 3
(4) 4
- 12 Mr Lim had \$100. He bought 2 crabs which cost \$30.50 each and some fishes which cost \$23.70. How much money had he left?
- (1) \$15.30
(2) \$45.80
(3) \$84.70
(4) \$184.70

13 Mdm Rosie sold only roses on Mother's Day. She sold 200 stalks of them in the morning and $\frac{2}{5}$ of the remainder in the afternoon. After that, she had $\frac{1}{2}$ of the roses left. How many stalks of roses did she sell in the afternoon?

- (1) 400
- (2) 600
- (3) 1000
- (4) 1200

14 The figure below is made up of 4 identical circles inside a square. The length of the square is 28 cm. Find the perimeter of the shaded part. (Take $\pi = \frac{22}{7}$)

- (1) 88 cm
- (2) 102 cm
- (3) 116 cm
- (4) 144 cm

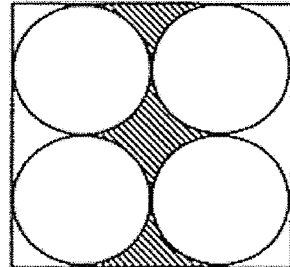

- 15 A survey was conducted to find out the favourite snack of a group of 50 children. They could only pick one type of snack and each type was picked by at least one child.

The table below showed the results of the survey. Given that the most popular snack is Mamee Monster and the least popular snack was prawn crackers, what was the greatest number of children who picked Potato chips ?

Favourite snacks

Mamee Monster	Potato Chips	Prawn Crackers	Chocolates
24	?	3	

- (1) 19
- (2) 23
- (3) 27
- (4) 4



Rosyth School
Preliminary Examination 2020
Mathematics
Paper 1
Primary 6

Name: _____

Register No. _____

Class: Pr 6 - _____

Group No.: _____

Date: 25 August 2020

Parent's Signature: _____

Total Time for Booklets A and B : 1 hour

Booklet B

Instructions to Pupils:

1. Do not open this booklet until you are told to do so.
2. Follow all instructions carefully.
3. You are **not** allowed to use a calculator.
4. Write your answers in the booklet.
5. Answer all questions.

Section	Maximum Mark	Marks Obtained
Paper 1 (Booklet B)	25	

* This booklet consists of 9 pages (including this cover page).

Questions 16 to 20 carry 1 mark each. Write your answers in the spaces provided. For questions which require units, give your answers in the units stated.

Do not write in this space

All diagrams in this paper are not drawn to scale unless stated otherwise.

(5 marks)

16 List all the common factors of 20 and 35.

Ans : _____

17 Express 3.2 as a percentage.

Ans : _____ %

18 At a carnival, 215 toys were sold in 4 days.
How many toys were sold on Tuesday?

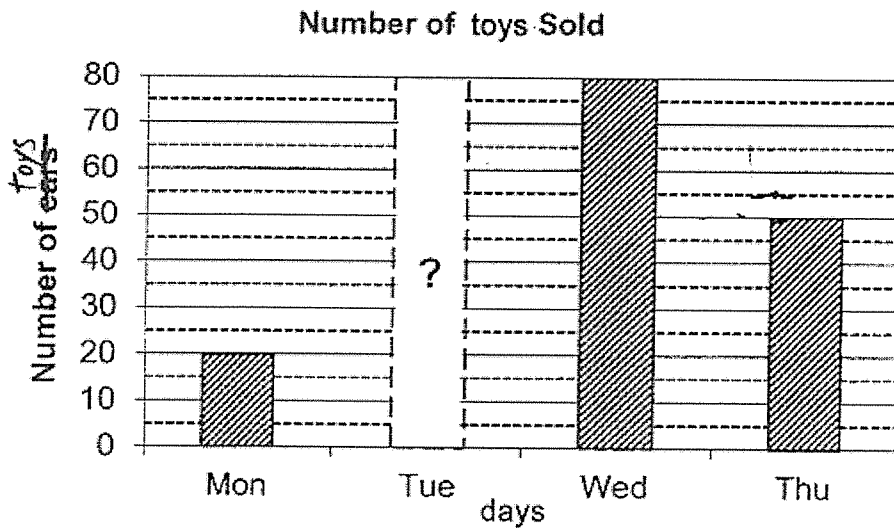

Ans : _____

- 19 The figure below shows a solid that is made up of 1-cm cubes. Find the volume of the solid.

Do not write in this space

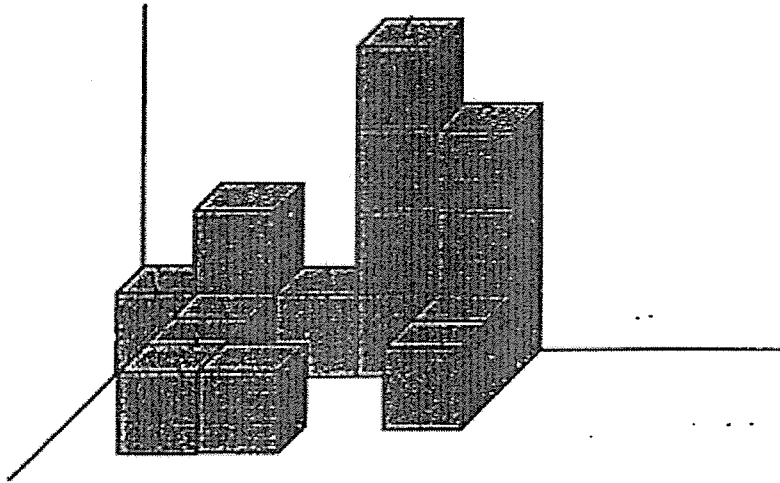

Ans : _____ cm³

- 20 Complete symmetric figure below with PQ as the line of symmetry.

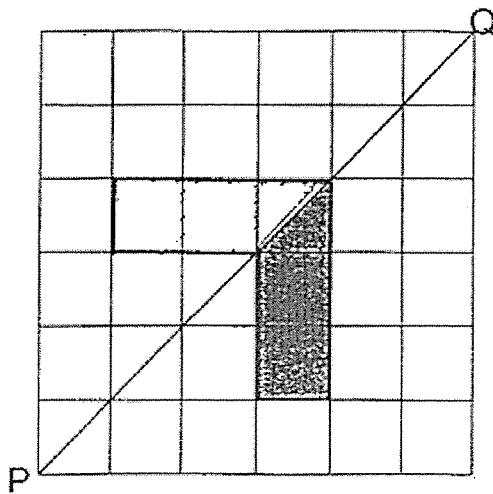

Questions 21 to 30 carry 2 marks each. Show your workings clearly in the space provided for each question and write your answers in the spaces provided. For questions which require units, give your answers in the units stated.

Do not write in this space

All diagrams in this paper are not drawn to scale unless stated otherwise.

(20 marks)

21 Find the value of $7 \div 8$. Give your answer correct to 2 decimal places.

Ans : _____



22 The figure below, not drawn to scale, is formed using 2 identical squares, 2 identical large equilateral triangles and 2 identical small equilateral triangles. The length of the square is 15 cm. Find the perimeter of the figure.

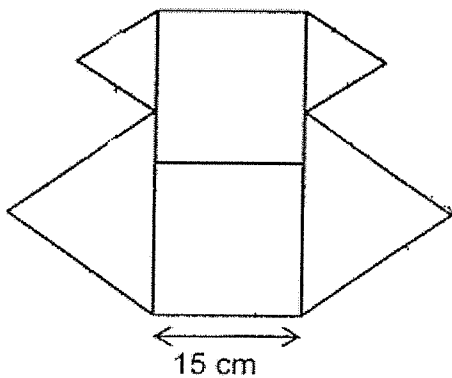

Ans : _____ cm

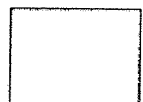

- 23 Nicole had some sugar.
 She used $\frac{1}{5}$ kg of the sugar to make cupcakes and $\frac{1}{3}$ of the sugar to make jelly. She had 140 g of sugar left. How many grams of sugar did Nicole have at first?

Do not write in this space

Ans : _____ g

- 24 ABCD and DEFA are identical trapeziums. $AG=GO=OH=HD$. What fraction of the figure is shaded? Leave your answer in the simplest form.

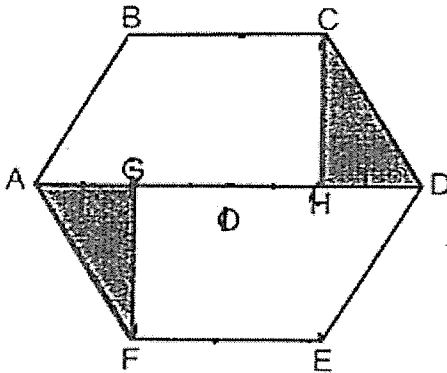

Ans : _____

- 25 Bridget is 12 years old now. Her cousin is y years younger than her. Find their combined age 5 years later in terms of y .

Do not write
in this space

Ans : _____

- 26 The table below shows the month of April in one year. Mr Osman plans to attend a course 38 days after 12 April. Which day will he be attending the course?

April						
Sun	Mon	Tue	Wed	Thu	Fri	Sat
					1	2
3	4	5	6	7	8	9
10	11	12	13	14	15	16
17	18	19	20	21	22	23
24	25	26	27	28	29	30

Ans : _____

- 27 James cuts out a square and a triangle from a rectangular strip of paper as shown below. Square ABCD has an area of 81cm^2 . Square ABCD has same the perimeter as Triangle XYZ. XY is 12 cm and XZ is 14 cm. Find the area of Triangle XYZ.

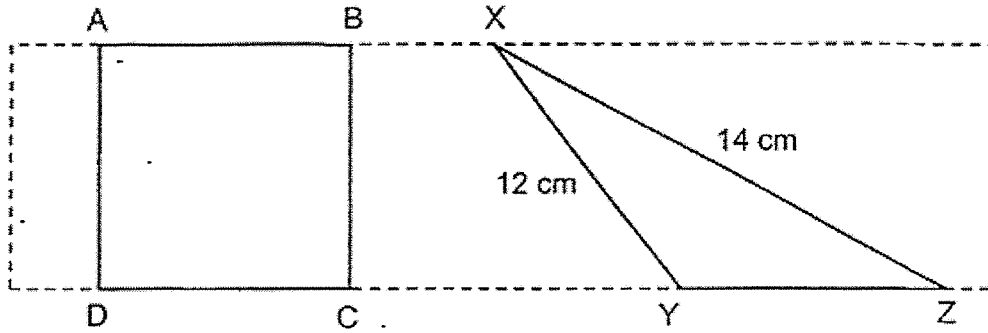

Do not write
in this space

Ans : _____ cm^2



Do not write
in this space

- 28 In the square grid, PQ is a straight line.
 PQ forms one side of a rhombus PQRS.
 Complete the drawing of the rhombus PQRS. Label the points R and S.

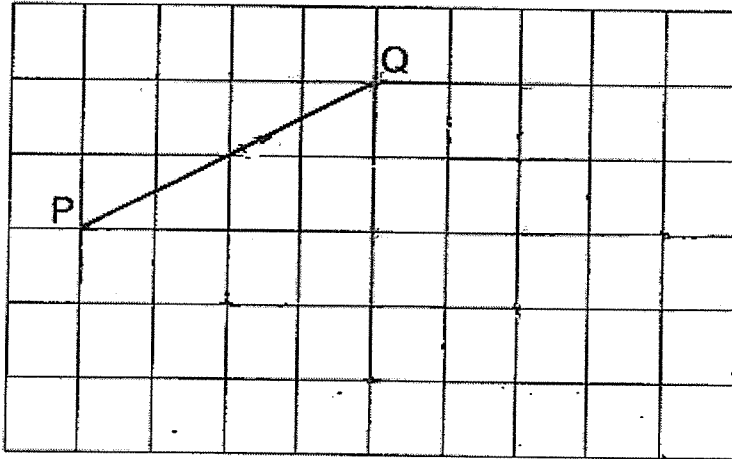

- 29 The figure below is made up of a parallelogram ABOE and a trapezium BCDO. $\angle EAB = 112^\circ$ and $\angle OBC = 138^\circ$. Find $\angle EOD$.

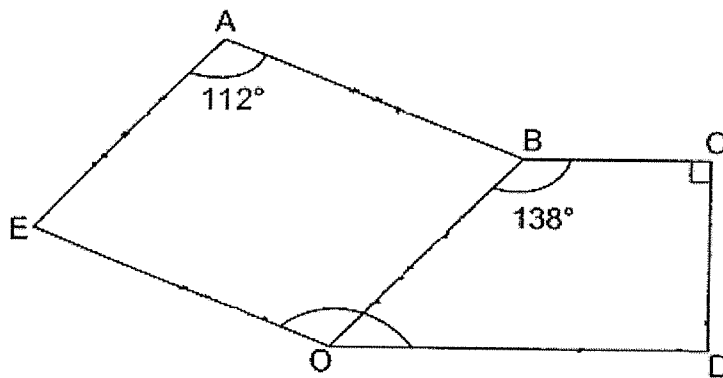

Ans : _____^o

30

At a carnival, 5 boys played darts at 2 stations from 9 a.m. to 10.30 a.m. At any time, 2 of them played while the other 3 boys watched. If each of them had the same amount of time playing darts, how many minutes did each boy play the game?

Do not write
in this space

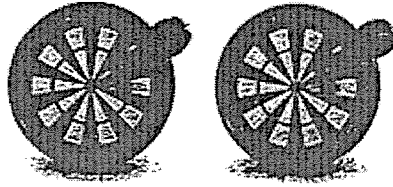

Ans : _____ min

End of paper
Have you checked your work?



Rosyth School
Preliminary Examination 2020
Mathematics
Paper 2
Primary 6

Name: _____

Register No. _____

Class: Pr 6 - _____

Group No: _____

Date: 25 August 2020

Parent's Signature: _____

Time: 1 h 30 min

Instructions to Pupils:

1. Do not open this booklet until you are told to do so.
2. Follow all instructions carefully.
3. **Show your workings clearly** as marks are awarded for correct working.
4. Write your answers in this booklet.
5. You are allowed to use a calculator.
6. Answer all questions.

Questions	Maximum Mark	Marks Obtained
Q 1 to 5	10	
Q 6 to 17	45	

Section	Maximum Mark	Marks Obtained
Paper 1	45	
Paper 2	55	
Total	100	

Questions 1 to 5 carry 2 marks each. Show your working clearly in the space provided for each question and write your answers in the spaces provided. For questions which require units, give your answers in the units stated.

(10 marks)

All diagrams in this paper are not drawn to scale unless stated otherwise.

Do not write in this space

1. Uncle Bob sells bubble tea at \$6.30 per cup of 700 ml. He only sells one size of bubble tea at his stall. Uncle Bob wants to make \$1000 a day. What is the minimum number of cups he must sell?

Ans : _____

2. Miss Lee bought $\frac{8}{9}$ kg of butter. $\frac{1}{3}$ kg of butter was needed to bake a cake. She wanted to bake the greatest possible number of cakes.

Each of the statements below is either true, false or not possible to tell from the information given. For each statement, put a tick (\checkmark) to indicate your answer.

Statement	True	False	Not possible to tell
The greatest number of cakes Miss Lee could bake was 2.			
After baking, Miss Lee had $\frac{2}{3}$ kg of butter left.			

3. The solid below is made up of 11 cubes.

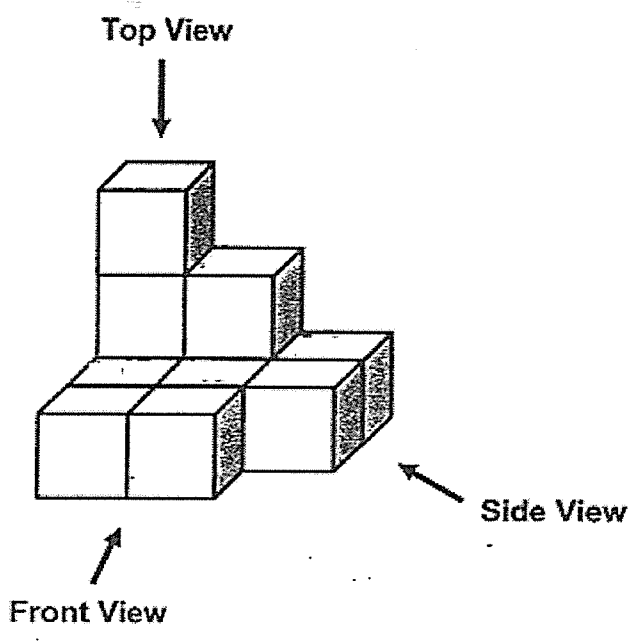

Do not write in this space

(a) Draw the side view of the solid on the grid below.

Side View

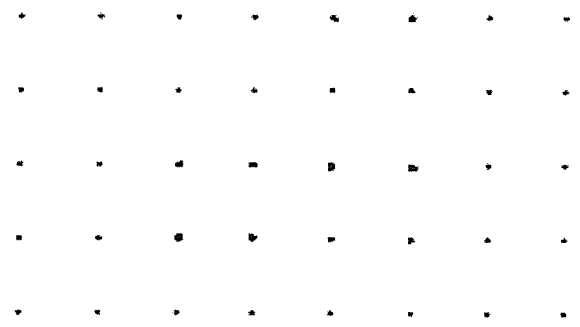

(b) Norah painted the whole solid including the base. Then she took it apart into its 11 cubes. How many of the cubes have 2 of the faces painted?

Ans : _____



4. The diagram below is drawn to scale. Use a protractor to find $\angle a$.

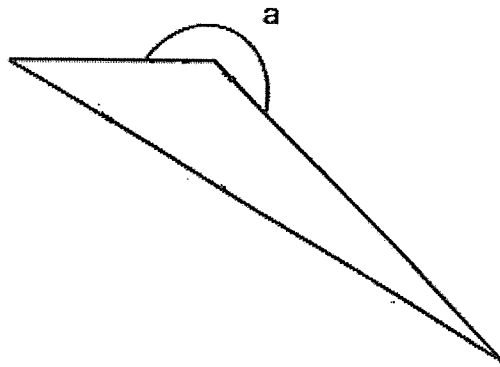

Ans : _____ °

Do not
write in
this
space

5. There are two numbers. One is 3 times the other. They have exactly four common factors. Three of the common factors are 1, 3 and 7. What are the two numbers?

Ans : _____ and _____

For Questions 6 to 17, show your working clearly in the space provided for each question and write your answers in the spaces provided. The number of marks available is shown in brackets [] at the end of each question or part-question. For questions which require units, give your answers in the units stated.

(45 marks)

All diagrams in this paper are not drawn to scale unless stated otherwise.

Do not
write in
this
space

6. A sum of money was shared among three girls, Maggie, Alice and Cecilia. Maggie received \$ m . Alice received twice as much money as Maggie. Cecilia received \$55 less than Alice.

- (a) Express the amount of Cecilia's money in terms of m .
(b) If $m = 35$, find the total sum of money shared by the three girls.

Ans : (a) _____ [1]

(b) _____ [2]



7. Mr Chan bought some pots of plants at \$15 each. He also bought an equal number of identical bags of soil for the plants. The average price of a pot of plant and a bag of soil was \$12.50. Mr Chan paid \$45 less for the bags of soil than the plants. How much did he spend on the plants?

Do not
write in
this
space

Ans : _____ [3]



8. The figure below, not drawn to scale, is made up of a circle and a right-angled triangle XYZ. XY = YZ. XY is 20 cm. YZ is the diameter of the circle. Find the area of the shaded part. (Take $\pi = 3.14$)

Do not write in this space

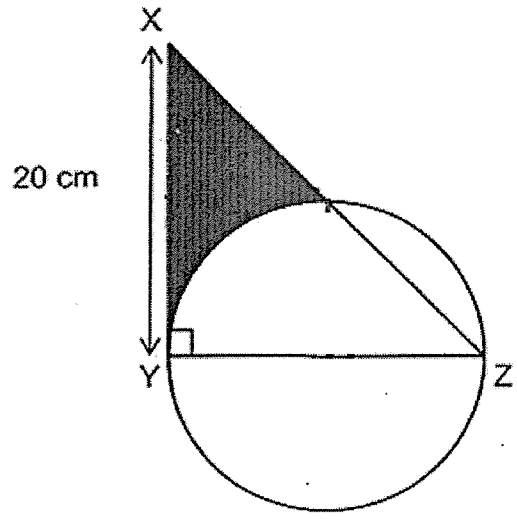

Ans : _____ [3]



9. A rectangular tank measuring 60 cm long by 15 cm wide by 40 cm high was $\frac{1}{3}$ filled with water at first. Devi filled 4 identical bottles with water to the brim. Then she poured all of the water from the bottles into the rectangular tank and the tank became $\frac{3}{4}$ full. What was the capacity of each bottle?

Do not write in this space

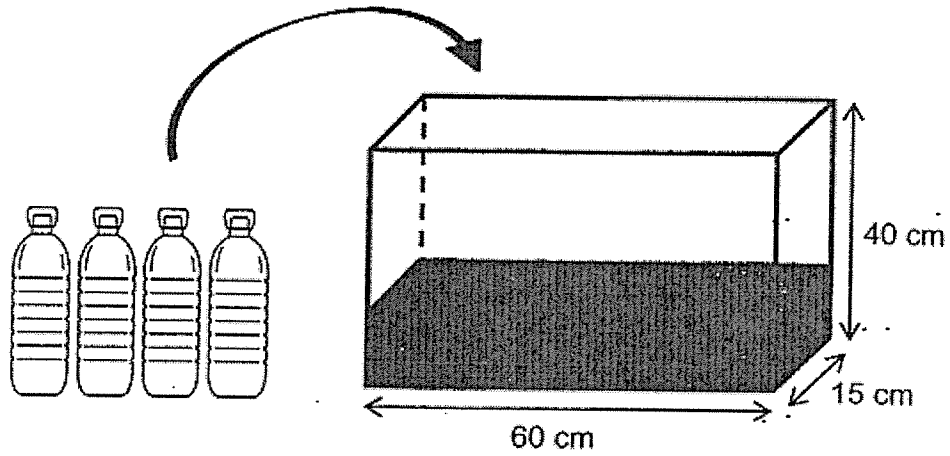

Ans : _____ [3]

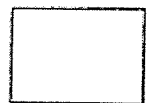

10.

The figure is made up of a rectangle ABCD and 2 identical squares DEFG and HIJF. EJ and HG are straight lines. Find $\angle p$.

Do not write in this space

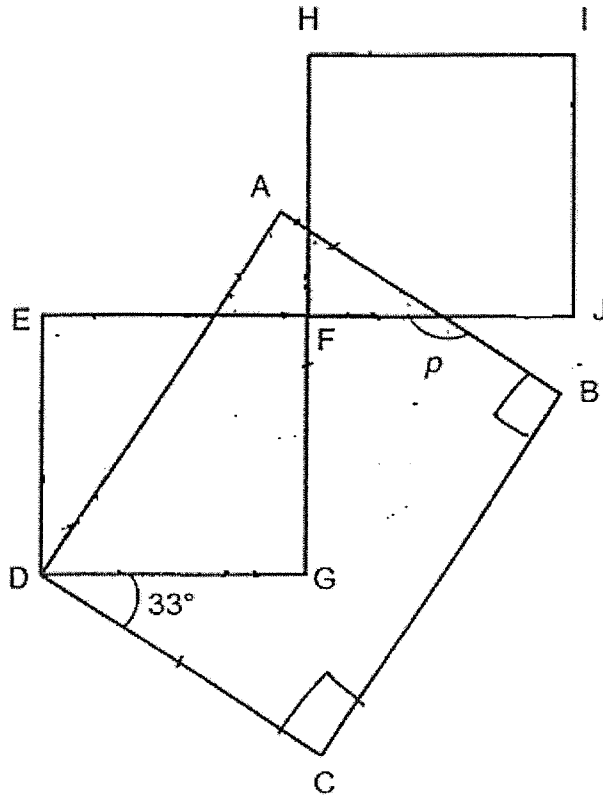

Ans : _____ [3]

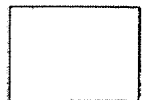

11. Alex and Benjamin were each given some stickers. Alex had four times as many stickers as Benjamin. After Alex gave away 203 stickers and Benjamin gave away 26 stickers, Benjamin had three times as many stickers left as Alex. How many more stickers did Alex have than Benjamin at first ?

Do not write in this space

Ans : _____ [4]



12. Mel has a total of 648 black and white buttons. He has 360 more black buttons than white buttons. He puts all the black buttons equally into empty black boxes and puts all the white buttons equally into empty white boxes. There are thrice as many black boxes as white boxes. Each black box contains 4 more buttons than each white box. How many buttons are there in each white box?

Do not
write in
this
space

Ans : _____ [4]

13. The graph shows the number of visitors to the museum from January to June.

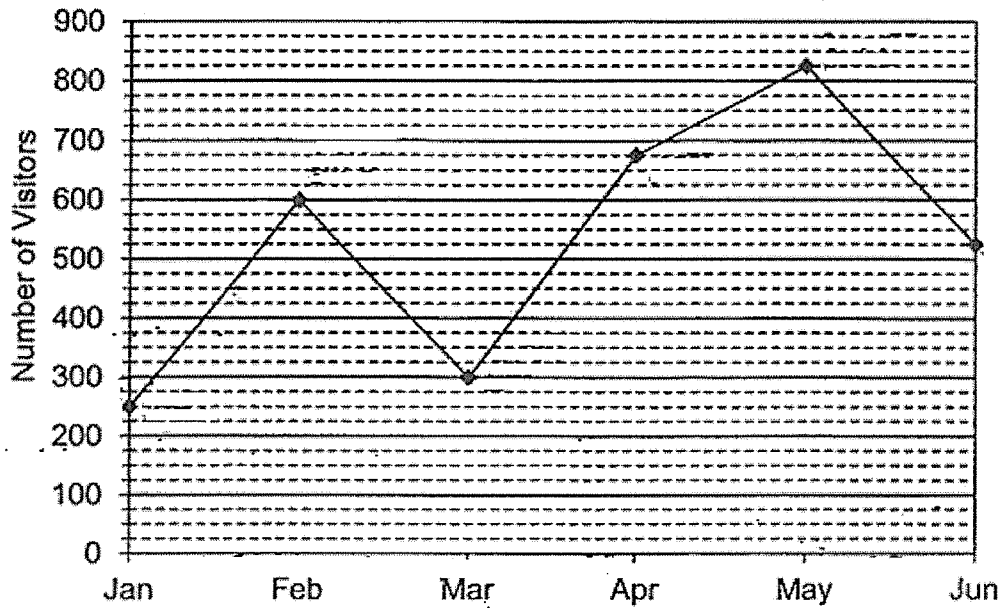

Do not write in this space

- In which one-month period was there the greatest change in the number of visitors to the museum ?
- In month of June, for every adult visitor, two visitors were children. How many visitors were children in June?
- From January to February what was the percentage increase in the number of visitors to the meseum ?

Ans : a) Between _____ and _____ [1]

b) _____ [1]

c) _____ [2]

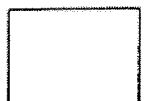

14. The figure below shows a rectangle and 11 identical shaded circles. Each shaded circle is in contact with those next to it. The rectangle has a perimeter of 384 cm.

Do not write in this space

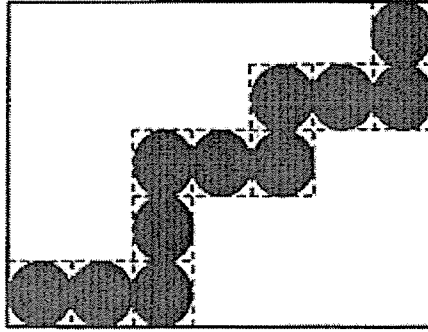

- a) Find the radius of one circle.
- b) More identical shaded circles are added. The whole rectangle is then covered with a maximum number of shaded circles. Find the area of the rectangle that is not covered by the shaded circles.
(Take $\pi = \frac{22}{7}$)

Ans : a) _____ [1]

b) _____ [3]



15. The figure below is made up of a right-angled triangle ABE and two isosceles triangles ACF and CDF. $AC = FC$ and $DF = DC$. Find $\angle ABC$.

Do not write in this space

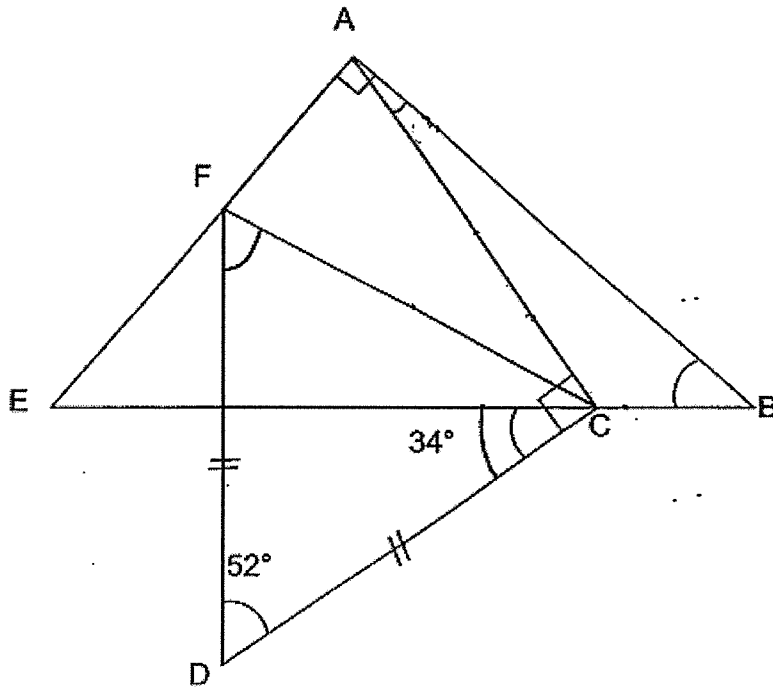

Ans: _____ [4]



16. Yanti decorated the sides of a rectangular board with 16 buttons. The buttons were placed at an equal distance apart along all the sides of the board. The length of the board was 210 cm. The figure below shows part of her layout.

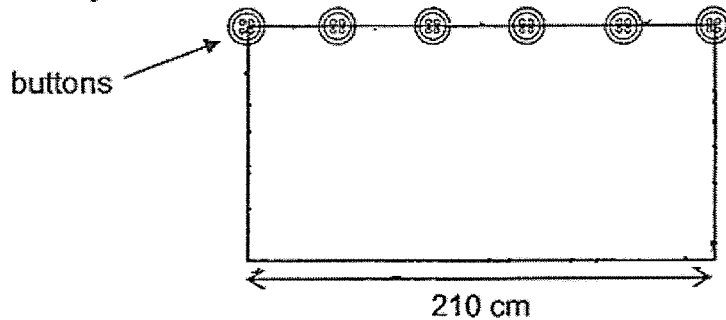

- a) What was the breadth of the rectangular board?
- b) After that, Yanti decided to use a combination of ribbons and buttons. She spent $\frac{1}{4}$ of her money on 16 buttons and 4 ribbons. The cost of each ribbon is twice the cost of each button. Yanti bought some more ribbons with $\frac{1}{2}$ of her remaining money. How many ribbons did she buy altogether in the end ?

Do not write in this space

Ans : a) _____ [2]

b) _____ [3]



17. Mdm Yap sold some T-shirts in March. The table belows shows the number of T-shirts sold for size S and L but not size M and XL.

Size of T-shirt	Number of T-shirt
S	80
M	?
L	400
XL	?

Do not
write in
this
space

- (a) 50% of the T-shirt were in size L. The ratio of the number of T-shirt in size M to size XL is 5 : 11. How many of the T-shirts were in size M?
- (b) Mdm Yap sold all of her T-shirts in the size of S at the usual price and and all of her T-shirts in size M at a discount of 25%. She received a total of \$1620 from the sale. The amount of money she received from the sale of the T-shirt in size M was \$180 more than the sale of T-shirt in size S. What is the price difference in the cost of a T-shirt in size S and a T-shirt in size M at their usual price?

Ans : a) _____ [2]

b) _____ [3]



End of paper
Have you checked your work?

SCHOOL : ROSYTH PRIMARY SCHOOL
 LEVEL : PRIMARY 6
 SUBJECT : MATH
 TERM : 2020 PRELIM

PAPER 1 BOOKLET A

Q 1	Q2	Q3	Q4	Q5	Q6	Q7	Q8	Q9	Q10
3	1	2	2	3	4	4	2	2	3

Q 11	Q12	Q13	Q14	Q15
3	1	1	3	1

PAPER 1 BOOKLET B

Q16)	1, 5
Q17)	320%
Q18)	65
Q19)	17 cm ³
Q20)	
Q21)	0.88
Q22)	150cm
Q23)	510g
Q24)	$\frac{1}{6}$

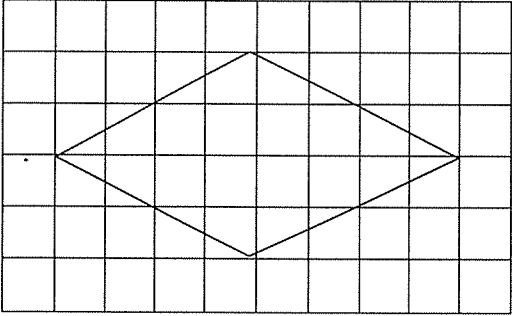
Q25)	$(34 - y)$
Q26)	Fri
Q27)	45cm ²
Q28)	
Q29)	154°
Q30)	36 min

PAPER 2

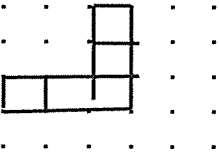
Q1)	$\$1000 \div \$6.30 = 158 \text{ R } \$460$ $158 + 1 = 159$
Q2)	True False
Q3)	a)  b)2
Q4)	$a = 360 - 135 = 225^\circ$
Q5)	21 and 63
Q6)	A---- $2 \times \$m = \$(2m)$ C---- $\$(2m) - \$55 = \$(2m - 55)$ $\$35 + \$(2 \times 35) + \$(2 \times 35 - 55)$ $=\$120$

Q7)	$\$12.50 \times 2 + \25 $\$25 - \$15 = \$10$ $\$15 - \$10 = \$5$ $\$45 \div 5 = 9$ $9 \times \$15 = 135$
Q8)	$r = 20\text{cm} \div 2 = 10\text{cm}$ area of 1  $\frac{1}{4} \times 10 \times 10 \times 3.14 = 78.5$ $\frac{1}{2} \times 10 \text{ cm} \times 10\text{cm} = 50\text{cm}^2$ $\frac{1}{2} \times 20\text{cm} \times 20\text{cm} = 200\text{cm}^2$ $200\text{cm}^2 - 50\text{cm}^2 - 78.5\text{cm}^2$ $= 71.5\text{cm}^2$
Q9)	$\frac{5}{12} \times 40 \times 15 \times 60 = 15000$ $15000 \div 4 = 3750\text{ml}$
Q10)	$ADG = 90 - 33 = 57$ $EDA = 90 - 57 = 33$ $X = 180 - 90 - 33 = 57$ $P = 57 + 90^\circ$
Q11)	$12u - 609 = 1u - 26$ $11u = 583 \div 11 = 53$ $4u - 1u = 3u$ $3u = 3 \times 53 = 159$
Q12)	$540 \div 3 = 168$ $168 - 144 = 24$ $24 \div 4 = 6$ $144 \div 6 = 24$
Q13)	a) Mar and Apr b) 350 c) 140%
Q14)	a) 8cm b) 1920cm ²
Q15)	43°

Q16)	a)126cm b)22
Q17)	a)100 b)\$3